

4615 SBus ATM Adapter Users Guide

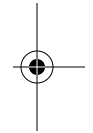

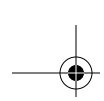

4615 SBus ATM Adapter Users Guide



Document No. UG04615-003, REVE

Print Date: March 12, 1998



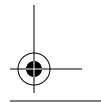
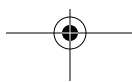
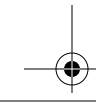
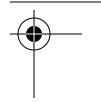
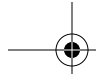
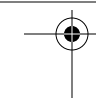

Copyright Notice

© 1996, 1997 by Interphase Corporation. All rights reserved.

Printed in the United States of America, 1998.

This manual is licensed by Interphase to the user for internal use only and is protected by copyright. The user is authorized to download and print a copy of this manual if the user has purchased one or more of the Interphase adapters described herein. All copies of this manual shall include the copyright notice contained herein. No part of this manual, whether modified or not, may be incorporated into user's documentation without prior written approval of

Interphase Corporation
13800 Senlac
Dallas, Texas 75234
Phone: (214) 654-5000
Fax: (214) 654-5500

Disclaimer

Information in this manual supersedes any preliminary specifications, preliminary data sheets, and prior versions of this manual. While every effort has been made to ensure the accuracy of this manual, Interphase Corporation assumes no liability resulting from omissions, or from the use of information obtained from this manual. Interphase Corporation reserves the right to revise this manual without obligation to notify any person of such revision. Information available after the printing of this manual will be in one or more Read Me First documents. Each product shipment includes all current Read Me First documents. All current Read Me First documents are also available on our web site.

THIS MANUAL IS PROVIDED "AS IS." INTERPHASE DISCLAIMS ALL WARRANTIES, EXPRESS OR IMPLIED, INCLUDING THOSE OF MERCHANTABILITY AND FITNESS FOR A PARTICULAR PURPOSE OR ARISING FROM A COURSE OF DEALING, USAGE, OR TRADE PRACTICE. IN NO EVENT SHALL INTERPHASE BE LIABLE FOR ANY INDIRECT, SPECIAL, CONSEQUENTIAL, OR INCIDENTAL DAMAGES, INCLUDING, WITHOUT LIMITATION, LOST PROFITS OR LOSS OR DAMAGE TO DATA ARISING OUT OF THE USE OR INABILITY TO USE THIS MANUAL, EVEN IF ADVISED OF THE POSSIBILITY OF SUCH DAMAGES.

Trademark Acknowledgments

Interphase® and Syncard® are registered trademarks and CellView™, (i)chip™, ADSLWatch™, ADSLEye™, SynWatch™, SynEye™, FibreView™, and the Interphase logo are trademarks of Interphase Corporation.

Microsoft®, MS-DOS®, Windows®, and Windows NT® are registered trademarks of Microsoft Corp.

Novell® and NetWare® are registered trademarks of Novell, Inc.

Solaris® and NFS® are registered trademarks and SunOS™ and ONC™ are trademarks of Sun Microsystems, Inc. Sun is a trademark or registered trademark of Sun Microsystems, Inc.

SPARC® is a registered trademark of SPARC International, Inc. SPARCstation™, SPARCserver™, SPARCcenter™, UltraSPARC™, Ultra™, and Ultra Enterprise™ are trademarks of SPARC International, Inc., licensed exclusively to Sun Microsystems, Inc. LattisCell™, EtherCell™, Bay Networks™, and SAHI™ are trademarks of Bay Networks, Inc.

UNIX® is a registered trademark in the United States and other countries, licensed exclusively through X/Open Company Ltd.

IBM® and OS/2® are registered trademarks and AIX™ and PowerPC™ are trademarks of International Business Machines Corporation.

HP-UX® is a registered trademark and Tachyon™ and Precision Bus™ are trademarks of Hewlett-Packard Company.

Intel® and Pentium® are registered trademarks of Intel Corporation.

TI® is a registered trademark of Texas Instruments.

Compu-shield® is a registered trademark of Stewart Connectors Systems, Inc.

Tundra® is a registered trademark and Universe™ is a trademark of Tundra Semiconductor Corporation.

Ethernet® is a registered trademark of Xerox Corporation.

DG/UX® and AViiON® are registered trademarks of Data General Corporation.

Apple® and Power Macintosh® are registered trademarks and Macintosh™, MacOS™, Mac™, AppleTalk™, and Open Transport™ are trademarks of Apple Computer, Inc.

NCR® is a registered trademark of NCR Corporation.

Silicon Graphics® is a registered trademark and SGI™, Indigo™, Indy™, Indigo²™, IRIX™, IRIS™, IRIS Indigo™, Challenge™, and Challenge M™ are trademarks of Silicon Graphics, Inc.

ALPHA™ is a trademark of Digital Equipment Corporation.

Gadzoox™ is a trademark of Gadzoox Microsystems, Inc.

Seagate™ and Barracuda™ are trademarks of Seagate Technology, Inc.

ST® is a registered trademark of AT&T.

SCO, The Santa Cruz Operation, SCO OpenServer, and UnixWare are trademarks or registered trademarks of The Santa Cruz Operation, Inc.

SUPERNET™ is a trademark of Advanced Micro Devices, Inc.

Cisco® is a registered trademark and Cisco Systems™ is a trademark of Cisco Systems, Inc.

Adobe® and Acrobat® are registered trademarks of Adobe Systems Incorporated.

CompactPCI® and PICMG® are registered trademarks of the PCI Industrial Computer Manufacturers Group.

Assistance

Product Purchased from Reseller

Contact the reseller or distributor if

- You need ordering, service or any technical assistance.
- You received a damaged, incomplete or incorrect product.

Product Purchased Directly from Interphase Corporation

Contact Interphase Corporation directly for assistance with this, or any other Interphase Corporation product. Please have your purchase order and serial numbers ready.

Customer Support

United States:	Telephone: (214) 654-5555
	Fax: (214) 654-5500
	E-Mail: intouch@iphase.com
United Kingdom:	Telephone: + 44 (0) 1869-321222
	Fax: + 44 (0) 1869-247720
France:	Telephone: + 33 (0) 1 41 15 44 00
	Fax: + 33 (0) 1 41 15 12 13
Asia/Pacific Rim:	Telephone: + 81 35423 6513
	Fax: + 81 35423 6511

World Wide Web

<http://www.iphase.com>

Anonymous FTP Server

<ftp://www.iphase.com>

Safety Precautions

The following general safety precautions must be observed during all phases of operation of this equipment. Failure to comply with these precautions or with specific warnings elsewhere in this manual violates safety standards of design, manufacture, and intended use of the equipment. Interphase Corporation assumes no liability for the user's failure to comply with these requirements. You, as the user of the product, must observe all stated warnings and safety precautions in order to safely operate the equipment in your environment.

Do Not Substitute Parts or Modify Equipment

Because of the danger of introducing additional hazards, do not install substitute parts or perform any unauthorized modification of the equipment. Contact your local Interphase representative for service and repair to ensure that safety features are maintained.

Ground the Instrument

To minimize shock hazard, the equipment chassis and enclosure must be connected to an electrical ground. The power cable must either be plugged into an approved three-contact electrical outlet or used with a three-contact to two-contact adapter, with the grounding wire (green) firmly connected to an electrical ground (safety ground) at the power outlet.

Do Not Operate in an Explosive Atmosphere

Do not operate the equipment in the presence of flammable gases or fumes. Operation of any electrical equipment in such an environment constitutes a definite safety hazard.

Keep away from Live Circuits

Do not install or replace the component with power cable connected. Under certain conditions, dangerous voltages may exist even with the power cable removed. To avoid injuries, always disconnect power and discharge circuits before touching them.

Observe Dangerous Procedure Warnings

Warnings precede potentially dangerous procedures throughout this manual. Instructions contained in the warnings must be followed. You should also employ all other safety precautions which you deem

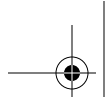

necessary for the operation of the equipment in your operating environment.



WARNING

This equipment generates, uses, and can radiate electromagnetic energy. It may cause or be susceptible to electromagnetic interference (EMI) if not installed and used in a cabinet with adequate EMI protection.

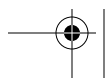

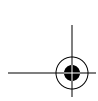

4615 FCC Regulatory Compliance

This equipment has been tested and found to comply with the limits for a Class A digital device, pursuant to part 15 of the FCC Rules. These limits are designed to provide reasonable protection against harmful interference when the equipment is operated in a commercial environment. This equipment generates, uses, and can radiate radio frequency energy and, if not installed and used in accordance with the instruction manual, may cause harmful interference to radio communications. Operation of this equipment in a residential area is likely to cause harmful interference in which case the user will be required to correct the interference at his own expense.

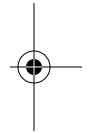

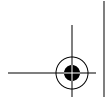

Interphase Fiber Products' Compliance

All Interphase fiber products comply with IEC regulations 825-1 and 825-2 for Class 1 laser devices.

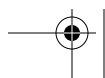
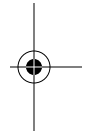

Declaration of Conformity

(according to ISO/IEC Guide 22 and EN 45014)

Manufacturer's Name: Interphase Corporation
**Manufacturer's Address and
Phone Number:** 13800 Senlac
Dallas, Texas 75234
U.S.A.
214/654-5000

declares, that the product:

Product Name: SBUS ATM UTP

Model Number: 4615

conforms to the following Standards:

Safety: EN 60950:1988 + A1, A2

EMC: EN 55022:1988 class A
EN 50082-1 Part 1 1992

Supplementary Information:

This product complies with the requirements of the **Low Voltage Directive 73/23/EEC** and the **EMC directive 89/336/EEC**.

Dallas, December 6, 1995

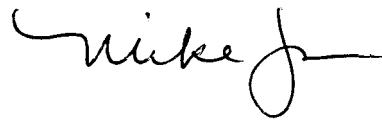

Mike Jobe, Quality Manager

European Contact:

Interphase European Headquarters, Centre d'affaires 10^{ème} Avenue, 855,
avenue Roger Salengro, 92370 Chaville - France
Phone: + 33 (0) 1 41 15 44 00; Fax: + 33 (0) 1 41 15 12 13

Declaration of Conformity

(according to ISO/IEC Guide 22 and EN 45014)

Manufacturer's Name: Interphase Corporation
**Manufacturer's Address and
Phone Number:** 13800 Senlac
Dallas, Texas 75234
U.S.A.
214/654-5000

declares, that the product:

Product Name: SBUS ATM FIBER

Model Number: 4915

conforms to the following Standards:

Safety: EN 60950:1988 + A1, A2
IEC 825 -1 & -2 1993

EMC: EN 55022:1988 class A
EN 50082-1 Part 1 1992

Supplementary Information:

This product complies with the requirements of the **Low Voltage Directive 73/23/EEC** and the **EMC directive 89/336/EEC**.

Dallas, March 4, 1996

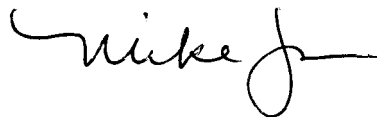

Mike Jobe, Quality Manager

European Contact:

Interphase European Headquarters, Centre d'affaires 10^{ème} Avenue, 855,
avenue Roger Salengro, 92370 Chaville - France
Phone: + 33 (0) 1 41 15 44 00; Fax: + 33 (0) 1 41 15 12 13

Declaration of Conformity

(according to ISO/IEC Guide 22 and EN 45014)

Manufacturer's Name: Interphase Corporation
**Manufacturer's Address and
Phone Number:** 13800 Senlac
Dallas, Texas 75234
U.S.A.
214/654-5000

declares, that the product:

Product Name: SBUS ATM 25MB

Model Number: 4625

conforms to the following Standards:

Safety: EN 60950:1988 + A1, A2

EMC: EN 55022:1988 class A
EN 50082-1 Part 1 1992

Supplementary Information:

This product complies with the requirements of the **Low Voltage Directive 73/23/EEC** and the **EMC directive 89/336/EEC**.

Dallas, May 21, 1996

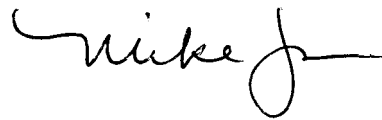

Mike Jobe, Quality Manager

European Contact:

Interphase European Headquarters, Centre d'affaires 10^{ème} Avenue, 855,
avenue Roger Salengro, 92370 Chaville - France
Phone: + 33 (0) 1 41 15 44 00; Fax: + 33 (0) 1 41 15 12 13

Contents

Preface	v
Audience	v
Icon Conventions	v
Text Conventions	vi
CHAPTER 1 Introduction	
Overview	1
Product Features	2
Minimum System Requirements	3
ATM Switch Requirements	3
CHAPTER 2 Installing Hardware	
Overview	5
Inspecting the Adapter	6
Installing the Adapter	7
Installing the Adapter in a SPARCstation 2	7
Installing the Adapter in a SPARCstation 10	11
Connecting the Adapter to the Network	15
CHAPTER 3 Installing the Solaris Driver	
Overview	19
Installing the Driver	20
Removing a Driver	25
CHAPTER 4 Configuring the Adapter Using CellView	
Overview	27
CellView Features	28

Contents

ATM Address.....	29
Configuration Requirements	30
Starting CellView	30
Setup	34
Setting Up UNI Signalling.....	36
Setting Up LAN Emulation Clients.....	38
LEC and LECS/LES ATM Address Settings.....	40
LEC PVC Settings.....	42
Setting Up IP-over-ATM Client and Server	44
IP-over-ATM Client and ARP Server Settings.....	46
IP-over-ATM PVC Settings.....	46
Setting Up a LAN Emulation Configuration Server	49
Setting Up a LAN Emulation Server.....	51
LES Settings.....	53
ELAN Client Mappings Settings	55
Statistics Information	58
Verifying Driver Installation.....	58
Troubleshooting.....	60
Global Settings	61
Controlling Application Display Settings	61
Displaying Signalling Connections Settings.....	63
Producing Debugging Messages.....	64

CHAPTER 5 Verification and Troubleshooting

Overview	67
Interpreting LEDs	67
Problems and Possible Solutions.....	69
Link and Status Problems	70
Bootup Problems.....	71
Network Problems.....	72

APPENDIX A Specifications

4615 Adapter Specifications.....	77
----------------------------------	----

Contents

Operating Environment	78
Storage Environment.....	78

APPENDIX B Updating the Adapter's FCode

Installing FCode Updates.....	79
-------------------------------	----

APPENDIX C ATM Technology Overview

Introduction to ATM	81
Virtual Circuits.....	82
Virtual Circuit Connections	82
Permanent Virtual Circuits	84
Switched Virtual Circuits	84
Fixed-Length Cells.....	85
Scalability	86
ATM Layers	86
Physical Layer.....	87
ATM Layer	88
ATM Adaptation Layer.....	88
AAL Service Classes.....	88
AAL Sublayers.....	90
SONET/SDH.....	92
Integrated Local Management Interface	92
LAN Emulation	93
LAN Emulation Multiple Protocol Support	93
MAC-Dependent Protocol Support.....	94
Legacy LAN Protocol Support	95
LAN Emulation Services.....	96
LAN Emulation Configuration Server	97
LAN Emulation Server	97
Broadcast and Unknown Server	98
LAN Emulation Protocol.....	99
Initialization	99
Configuration.....	100
Joining	100

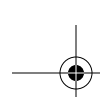

Contents

Registration and BUS Initialization..... 100
 Data Movement 101
 LAN Applications 101
 Multiprotocol Encapsulation over ATM AAL5 102
 Classical IP over ATM 103
 Classical IP Client Interface 105
 Classical IP ARP Server..... 105
 Data Movement 106
 CIP Applications 106
 For More Information..... 107

Glossary 109

Index 123

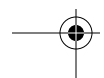

Preface

Audience

The procedures in this manual should be performed by a qualified technician with experience installing SBus adapters.

Icon Conventions

Icons draw your attention to especially important information:



NOTE

The Note icon indicates important points of interest related to the current subject.



CAUTION

The Caution icon brings to your attention those items or steps that, if not properly followed, could cause problems in your machine's configuration or operating system.

Text Conventions

**WARNING**

The Warning icon alerts you to steps or procedures that could be hazardous to your health, cause permanent damage to the equipment, or impose unpredictable results on the surrounding environment.

Text Conventions

The following conventions are used in this manual. Computer-generated text is shown in typewriter font. Examples of computer-generated text are: program output (such as the screen display during the software installation procedure), commands, directory names, file names, variables, prompts, and sections of program code.

Computer-generated text example

Commands to be entered by the user are printed in **bold Courier** type. For example:

```
cd /usr/tmp
```

Pressing the return key (↵ **Return**) at the end of the command line entry is assumed, when not explicitly shown. For example:

```
/bin/su
```

is the same as:

```
/bin/su ↵ Return
```

Required user input, when mixed with program output, is printed in **bold Courier** type. References to UNIX programs and manual page entries follow the standard UNIX conventions.

When a user command, system prompt, or system response is too long to fit on a single line, it will be shown as

```
Do you want the new kernel moved into\  
vmunix?[y]
```

with a backslash at either the beginning of the continued line or at the end of the previous line.



Text Conventions

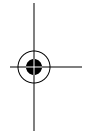

Introduction

1

Overview

The 4615 is a single-slot, SBus adapter that brings the advantages of high-speed ATM networking to Sun workstations and servers. This adapter supports a data rate of 155 Mbps over standard ATM networks, using SONET OC-3 for single-mode and multimode fiber, and SONET UTP for Category 5 copper.

The adapter's ATM Integrated Driver (ID 1.0) supports switched virtual circuits (SVCs) based on UNI 3.0/3.1 signalling. It also supports permanent virtual circuits (PVCs). It provides standards-based LAN Emulation or IP over ATM network connectivity using SVC or PVC communications.

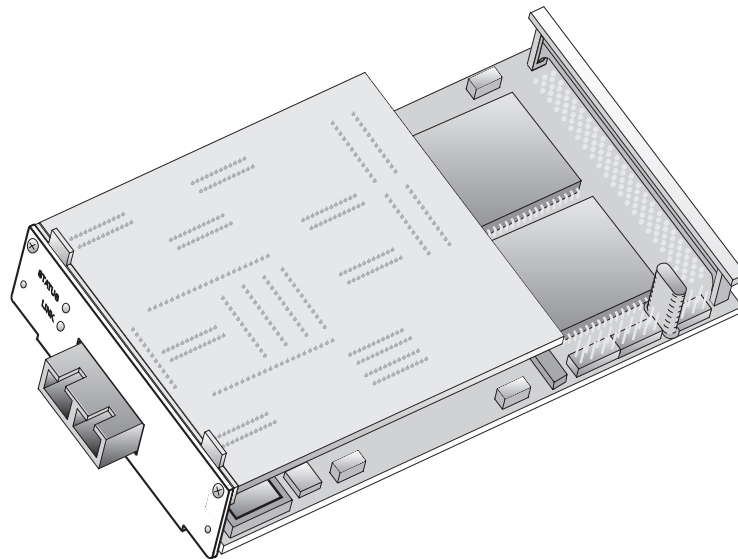

Figure 1-1. 4615 Adapter

Product Features

Product Features

- ATM AAL5 SVC support based on UNI signalling
- UNI ATM switch signalling
- ATM Forum LAN Emulation Client (LEC)
- ID 1.0 support for:
 - ATM Forum LAN Emulation services (LECS, LES, and BUS)
 - Classical IP over ATM, based on RFC-1577
 - PVCs, based on RFC-1483
- Fixed quality of service (QoS)
- OpenBoot compliant adapter interface
- OpenBoot support for adapter diagnostics
- DMA master for packet data
- SC Duplex interfaces available for:
 - 155 Mbps SONET OC-3c over multimode fiber
 - 155 Mbps SONET OC-3c over single-mode fiber
- RJ-45 interface available for 155 Mbps SONET UTP over copper
- Hardware-based Segmentation and Reassembly (SAR)
- LEDs for software status and active line
- Onboard flash memory
- 32 and 64-bit wide SBus transfers
- Support for European 155 Mbps SDH/STM-1 mode under Solaris

Minimum System Requirements

Installing the driver requires a system with the following minimum requirements:

- Sun SPARC™ system with SBus:
 - SPARCstation™ 2, 5, 10, 20, IPC, IPX, Classic, and LX
 - SPARCserver™ 600 MP Series
- Solaris operating system version 2.3 or later
- CD ROM drive
- Superuser login
- Hostname and IP addresses for the ATM adapter
- 5 MB of free disk space in the */root* partition
- 1 MB of free disk space in the */usr* partition
- IP address, broadcast address, net mask, and **ifconfig** options for each client being initialized

ATM Switch Requirements

Your ATM switch must be able to support the UNI 3.0/3.1 signalling standard for SVCs. Some switch vendors allow mixing of the two standards; some require that all ports be set to either UNI 3.0 or UNI 3.1. Check your switch documentation for the proper settings. The default setting for this adapter is UNI 3.0.

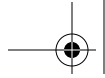

ATM Switch Requirements

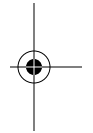

Installing Hardware

2

Overview

The 4615 SBus ATM Adapter can be installed in SBus-equipped Sun SPARC machines. *Minimum System Requirements* on page 3 identifies the specific compatible models.

This chapter includes the following procedures:

- Inspecting the adapter
- Installing the adapter in a host expansion slot
- Connecting the adapter to the network

The only tools required are a grounding strap and a #1 Phillips head screwdriver.

For additional information about SBus adapter installation, see:

- Sun hardware installation manuals, Sun Microsystems, Inc.
- *SBus Cards in Desktop SPARCstations* manual, Sun Microsystems, Inc.

Inspecting the Adapter

Inspecting the Adapter

Before installing the adapter in your computer, visually inspect it for damage that might have occurred during shipment from the factory.



CAUTION

The adapter is packed in an antistatic bag to protect it during shipment. Keep the adapter in its protective antistatic bag until you are ready to install it in the host computer. To prevent damage to the adapter due to electrostatic discharge, wear a grounding strap and handle the adapter only by its edges. Do not touch its components or any metal parts other than the faceplate.

1. Open the shipping container and carefully remove its contents.
2. Inspect each item for damage. If you find any omissions or damage, contact your network supplier and the carrier (for example, UPS or Federal Express) that delivered the package.

Installing the Adapter

The next two sections describe the steps required to install the 4615 in a SPARCstation 2 system and a SPARCstation 10 system, as examples. Installation in the other compatible systems is similar.



WARNING

Your computer operates at voltages that can be lethal. Before you remove the computer cover, carefully review the following procedures and observe all cautions and warnings to protect yourself and to prevent damage to the system. Use only insulated or nonconductive tools.

Installing the Adapter in a SPARCstation 2

1. Gracefully shut down your system using the following command:

```
shutdown -y -g 300 -i0 "For ATM Installation"
```
2. When the `ok` or `>` prompt appears, turn off the computer's power switch, and unplug the unit from its power source.
3. Unpack and inspect the adapter, as described in *Inspecting the Adapter* on page 6.
4. Remove the computer's cover as follows:
 - a. Remove the two screws in the upper corners of the back panel, shown in Figure 2-1:

Installing the Adapter

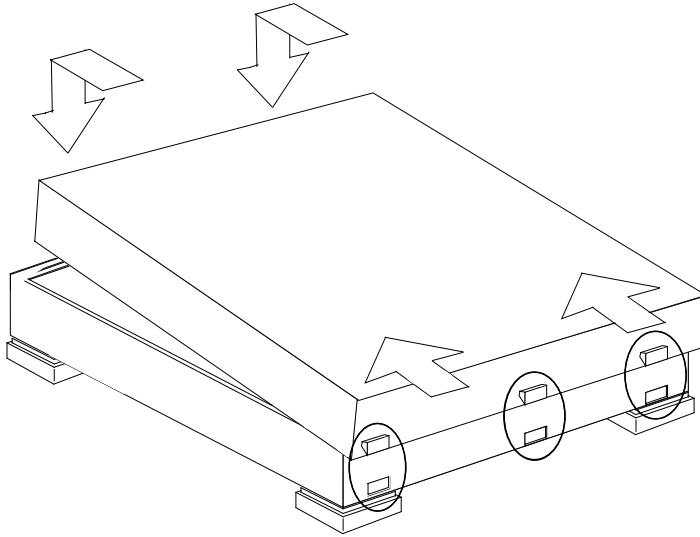

Figure 2-3. Replacing the Cover on a SPARCstation 2

- b. Lower the cover over the unit.
- c. Press down on the cover. The cover should extend beyond the frontplate of the unit. Insert and tighten the screws that attach the cover to the unit with a screwdriver.



WARNING

Personal injury and/or system damage can occur if the unit is not closed before the power is turned on.

Next, connect the ATM cables to the adapter as explained in *Connecting the Adapter to the Network* on page 15.

Installing the Adapter in a SPARCstation 10

1. Gracefully shut down your system using the following command:

```
shutdown -y -g 300 -i0 "For ATM Installation"
```
2. When the `ok` or `>` prompt appears, turn off the computer's power switch, and unplug the unit from its power source.
3. Unpack and inspect the adapter, as described in *Inspecting the Adapter* on page 6.
4. Because the adapter's faceplate is not used in the SPARCstation 10, remove the backplate extension from the adapter as follows:
 - a. Remove the screws that attach the backplate to the adapter's faceplate, as shown in Figure 2-4:

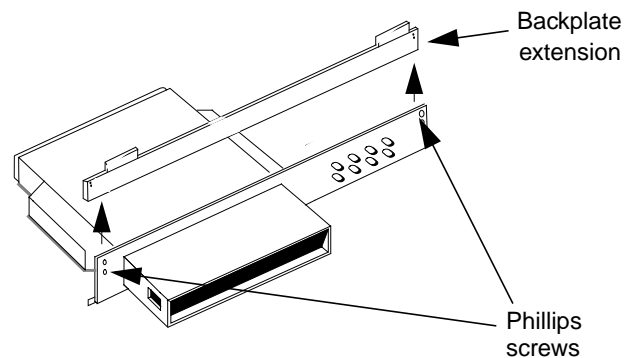

Figure 2-4. Removing the Backplate Extension

- b. Lift the backplate extension from the faceplate.

Installing the Adapter

5. Remove the computer's cover as follows:

- a.** Remove the two screws in the upper corners of the back panel, shown in Figure 2-5:

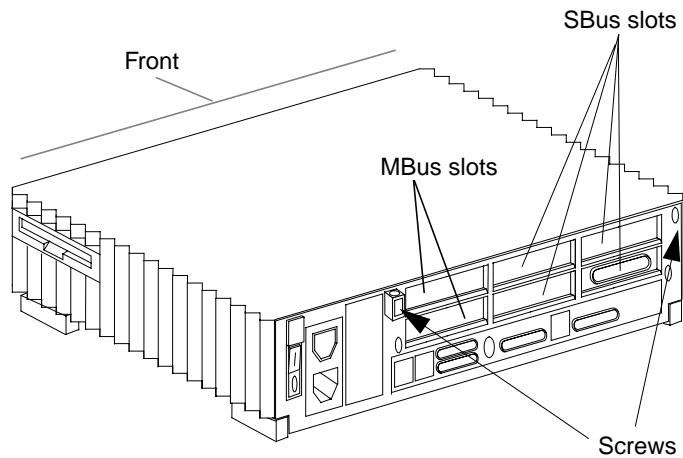
**Figure 2-5. Back Panel and Bus Slots of the SPARCstation 10**

- b.** Lift up slightly on the cover and slide it toward the front of the system to remove it. Make sure that the three plastic tabs on the inside of the cover clear the unit.
- 6.** Install the adapter in any of the unit's four SBus slots, which are shown in Figure 2-5, as follows:
 - a.** Remove the protector plate from the slot where you are installing the adapter, as shown in Figure 2-6:

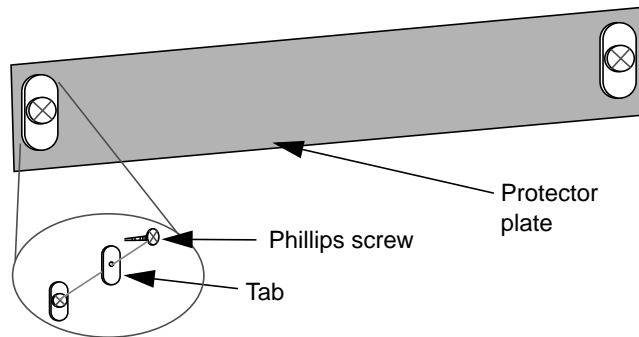

Figure 2-6. Removing the Protector Plate

- b.** Remove the dust cover from the ATM connector on the adapter.
- c.** Hold the adapter at an angle and insert it in the slot, as shown in Figure 2-7:

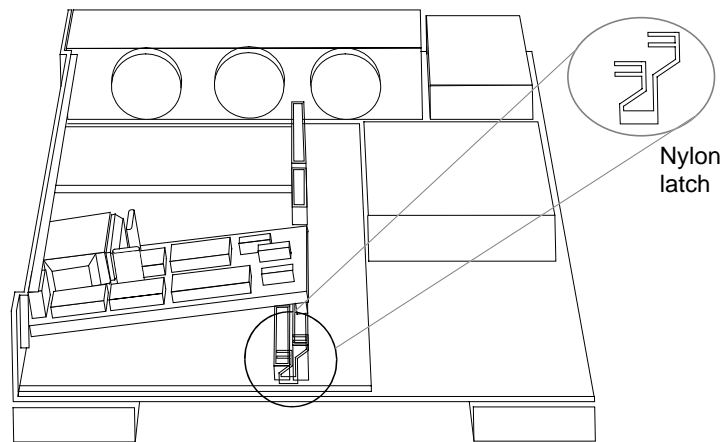

Figure 2-7. Placing the 4615 in a SPARCstation 10

Installing the Adapter

- d. Align the adapter's SBus connector with the slot's connector, and then carefully and firmly press the adapter into place.
 - e. Snap the back portion of the adapter into the nylon latches at each side of the adapter. Figure 2-7 on page 13 shows one of these latches.
If the adapter is in a lower slot, snap it into the lower latch. If the adapter is in an upper slot, snap it into the upper latch.
 - f. Using the tabs and screws removed from the protector plate, secure the adapter's faceplate to the SBus opening at the back of the unit.
7. Replace the system cover as follows:
- a. Hold the cover at an angle. Align the plastic tabs on the cover with the unit chassis slots and move the cover forward to insert the tabs in the slots.
 - b. Press down on the cover. The cover should extend beyond the front plate of the unit. Insert and tighten the screws holding the cover to the unit with a screwdriver.

**WARNING**

Personal injury and/or system damage can occur if the unit is not closed before the power is turned on.

Next, connect the ATM cables to the adapter as explained in *Connecting the Adapter to the Network* on page 15.

Connecting the Adapter to the Network

With the adapter installed as discussed in the previous section, you are now ready to connect the adapter to the ATM network. The cables and connectors required for the adapter are:

Connector	Medium	Configuration
SC Duplex	Single-mode fiber	82.5/125 micron
SC Duplex	Multi-mode fiber	62.5/125 micron
RJ-45	Category 5 copper	UTP



NOTE

The installation package for the adapter with RJ-45 connections includes the Ferrite RFI/EMI Suppressor.



WARNING

The 4615 single-mode media module uses a Class 1 Laser as data transfer elements. Take precautions to avoid eye exposure to the laser beams.

To connect the adapter to the network:

1. Attach the appropriate connector to the adapter.

Figure 2-8 shows the SC Duplex connection for ATM over fiber:

Connecting the Adapter to the Network

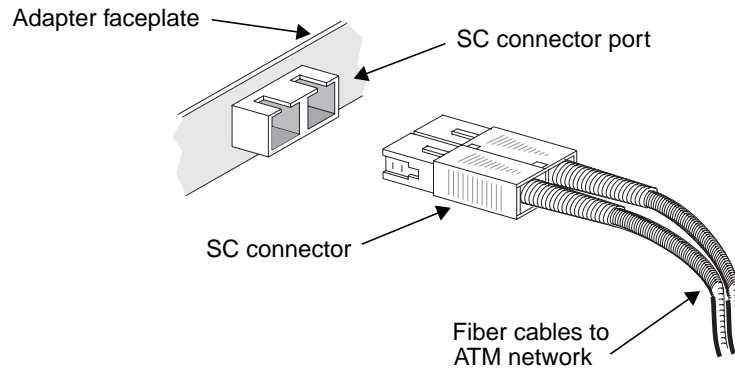

Figure 2-8. 4615 Adapter SC Duplex Connection

Figure 2-9 shows the standard RJ-45 connection for unshielded twisted pair (UTP):

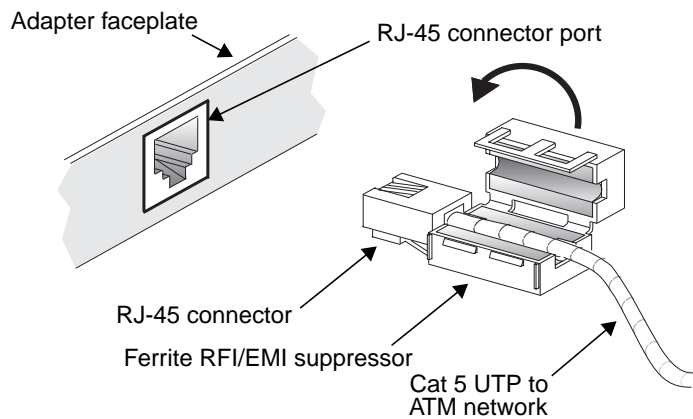
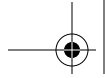

Figure 2-9. 4615 Adapter RJ-45 UTP Connection

2. If you are attaching an RJ-45 connector to the adapter, also attach the included Ferrite RFI/EMI suppressor to the network cable (shown in Figure 2-9) as follows:

- a. Open the suppressor and position it around the cable as close as possible to the RJ-45 connector.
 - b. Position the network cable through the center of the bottom half of the suppressor.
 - c. Close the top half of the suppressor over the cable until the suppressor halves lock into place.
3. Turn on the power to the computer.
4. To verify proper polarity, make sure the Link LED is lit. Figure 5-1 on page 68 shows the LEDs for adapters using an SC Duplex connection. Figure 5-2 on page 68 shows the LEDs for adapters using an RJ-45 type connection.
5. If the Link LED does not light, try the following:
 - If using an SC connector, swap the two cables.
 - If using an RJ-45 connector, inspect the connector on the UTP for a loose wire.

Next, you need to install the adapter driver. See Chapter 3, *Installing the Solaris Driver*, for information about installing the driver.



Connecting the Adapter to the Network

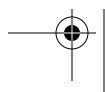
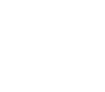
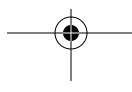
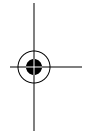

Installing the Solaris Driver

3

Overview

This chapter explains how to install the ATM Integrated Driver (ID 1.0), which supports up to eight SBus ATM adapters, in an end station running Solaris[®] version 2.3 or later. During installation, you can specify to configure up to four LAN Emulation Clients (LECs) and one IP over ATM client per adapter.

The ID 1.0 provides support for:

- LAN Emulation Clients
 - Ethernet[®]
 - Token Ring
- LAN Emulation services (LES, BUS, and LECS)
 - Ethernet
 - Token Ring
- IP over ATM Client, based on RFC-1577
- IP over ATM Server, based on RFC-1577
- PVC option for each client based on RFC-1483

You can enable the following LAN Emulation features for each adapter:

- Up to four LAN Emulation Clients (LECs)
- One IP over ATM Client
- One LAN Emulation Configuration Server (LECS)
- Up to eight LAN Emulation Servers (LESs) along with Broadcast and Unknown Servers (BUSs)
- One IP over ATM server

Installing the Driver

You can also set up PVCs with other end stations based on RFC-1483 standards.

The installation package includes CellView™, a cross-platform, graphical utility for configuring the adapter and displaying operating statistics.

See *Minimum System Requirements* on page 3 for information about system requirements for the driver.

If *Read Me First* documentation is in your installation kit, review it before installing the driver. It may contain changes and updates made to this users guide after the print date. Also, check for a **readme** file in the appropriate directory on the installation CD-ROM.

Installing the Driver



NOTE

You can install the driver before installing the adapter(s). Where feasible, however, we recommend that you install the adapter(s) first.

To install the driver:

1. Log in as **root**.
2. Check the available disk space by entering: `df -k`
3. If it is possible that a version of this driver is already installed, check for the existing driver installation by entering: `pkginfo`

If **INPHatm**, **INPHia**, **INPHipatm**, or **INPHpa** is in the list of installed packages, remove it as explained in *Removing a Driver* on page 25.

4. Insert the CD-ROM in the local drive and run the installation script by entering:

```
pkgadd -d /cdrom/cdrom0/Sparc_Solaris/INPHatm INPHatm
```

The installation might take several minutes to complete. Figure 3-1 on page 22 shows a sample of the output to the screen during a typical driver installation:

Installing the Driver

```
Processing package instance <INPHatm> from
</sw/atm/drivers/solaris/RELEASE/SX00322-C02>
SBus ATM Integrated driver
(sparc) SX00322-C02
Interphase Corporation
Using </opt> as the package base directory.
Enter maximum number of Adapters to configure (1-8) [1]: 2
Enter number of LE Clients for Adapter 0 to configure (0-4) [1]: 4
Enter hostname for interface li0 [enr-atm0]:
Enter hostname for interface li1 [enr-atm1]:
Enter hostname for interface li2 [enr-atm2]:
Enter hostname for interface li3 [enr-atm3]:
Enter number of IP-ATM Clients for Adapter 0 to configure (0-1) [0]: 1
Enter hostname for interface li32 [enr-atm32]:

Enter number of LE Clients for Adapter 1 to configure (0-4) [3]: 1
Enter hostname for interface li4 [enr-atm4]:
Enter number of IP-ATM Clients for Adapter 0 to configure (0-1) [0]:

Don't forget to add the following host names to the hosts database:

    enr-atm0
    enr-atm1
    enr-atm2
    enr-atm3
    enr-atm32
    enr-atm4

Don't forget to update your netmasks database with the
correct information for the 7 VLAN(s).

## Processing package information.
## Processing system information.
## Verifying disk space requirements.
## Checking for conflicts with packages already installed.
## Checking for setuid/setgid programs.

This package contains scripts which will be executed with super-user permission
during the process of installing this package.

Do you want to continue with the installation of this package [y,n,?]: y
```

Figure 3-1. Sample INPHatm Installation Script

5. Answer the prompts as follows:

- a. Enter maximum number of Adapters to configure (1-8) [1]:

This is the number of SBus ATM adapters installed in the end station. A maximum of eight adapters can be installed per end station. Press **Enter** to accept the default of one adapter, or enter the actual number of installed adapters (1–8).

- b. Enter number of LE Clients for Adapter <x> to configure (0-4) [1]:

This is the number of LECs you want to initialize for Adapter<x>. You can initialize a maximum of four LECs per adapter. You also have the option of not initializing any LECs on the adapter. Press **Enter** to accept the default of one LEC, or enter the actual quantity (0 – 4).

- c. Enter hostname for interface li<n>:

This is the hostname for the IP interface **li**<n>, where <n> ranges from 0 – 31 and represents the IP interface number of the LEC. Clients are mapped to the IP interface with the formula:

IP interface = (adapter number * 4) + client number

For example,

```
li0 = adapter 0, LEC 0
li1 = adapter 0, LEC 1
li2 = adapter 0, LEC 2
li3 = adapter 0, LEC 3
li4 = adapter 1, LEC 0
li5 = adapter 1, LEC 1
...
li31 = adapter 7, LEC 3
```

Installing the Driver

- d.** Enter number of IP-ATM Clients for Adapter 0 to configure (0-1) [0]:

You can initialize only one IP-over-ATM client per adapter. Press **Enter** to accept the default of zero, or enter **1** to initialize one IP-over-ATM client.

- e.** Enter hostname for interface li<n>:

This prompt appears **only if you initialized an IP-over-ATM client**.

The IP interface number <n> is the adapter number + 32. For example, for the IP-over-ATM client on Adapter 0, <n> is 32, and for Adapter 7 <n> is 39.

- f.** If you are installing more than one adapter, repeat substeps **b** – **e** until all adapters are processed.

Various advisory and status messages appear as the adapters are processed.

- g.** At the final prompt, Do you want to continue with the installation of this package, respond with **y** if you want to continue, or respond with **n** to cancel the installation.

- 6.** When installation of the driver is complete, remove the CD-ROM from the local drive and reboot the machine with the command:

```
shutdown -y -i6 -g0
```

If you have not yet installed the adapter(s), shut down the machine and do so now, as described in Chapter 2, *Installing Hardware*.

Next, with the driver and adapter(s) installed, start the CellView utility and configure the adapter(s) as described in Chapter 4, *Configuring the Adapter Using CellView*.



CAUTION

All configuration data is stored in the file `/etc/atm/cvconf`, for which an online man page is available. Use the CellView utility to modify the parameters instead of editing them manually. If the parameters get out of sync, the driver may not work properly.

If for some reason CellView does not run on your system, you can use command-line utilities (such as `lec`, `les`, and `lecs`) to modify the software currently running. However, these commands do not change the permanent settings in the `cvconf` file. The effects of these commands are lost when the machine is turned off or restarted.

Do not mix the running of command-line and CellView utilities. Use one method consistently, or unpredictable results can occur.

Removing a Driver

To remove a driver from the end station, do the following:

1. Log in as `root`.
2. Enter the `pkgrm` command and the driver name. For example, to remove the driver `INPHatm`, enter:

```
pkgrm INPHatm
```
3. Answer the prompts or press **Enter** to accept each default, as shown in Figure 3-2:

Removing a Driver

```
The following package is currently installed:
INPHatm      4615 SBus ATM Integrated Driver
              (sparc) SX00322-C02

Do you want to remove this package [y,n,?,q] y
## Removing installed package instance <INPHatm>

This package contains scripts which will be executed
with super-user permission during the process of removing this package.

Do you want to continue with the removal of this package [y,n,?,q] y
## Verifying package dependencies.
## Processing package information.
## Executing preremove script.
Device busy
Cannot unload module: ia
Will be unloaded upon reboot.
Device busy
Cannot unload module: li
Will be unloaded upon reboot.
Usage: /usr/sbin/unlink name

## Removing pathnames in class <sed>
Modifying /etc/path_to_inst
Modifying /etc/devlink.tab
## Removing pathnames in class <none>
/usr/share/man/man7/li.7
/usr/share/man/man7/ia.7
/usr/share/man/man1m/sigstat.1m

:
:
/bin/cvconf
/bin/cellview
/Xlphase
## Updating system information.
Removal of <INPHatm> was successful.
```

Figure 3-2. Sample of Driver Removal

4. Reboot the machine by typing:

```
shutdown -y -g0 -i6
```

Configuring the Adapter Using CellView

4

Overview

This chapter provides information about CellView, a cross-platform, GUI utility that enables you to configure clients and services for adapters across a wide range of operating systems. It explains how to use CellView on all compatible operating systems other than NetWare. (Your adapter might not support all of the operating systems that are compatible with CellView.)



NOTE

For ATM adapters that consist of a motherboard and 1 or 2 PMC ATM daughtercards, the term *adapter* in this chapter refers to the daughtercard.

This chapter describes the following:

- CellView features
- ATM address format
- Configuration requirements
- CellView startup procedure
- Setup procedures
- CellView statistics
- CellView global settings

CellView Features

Because of differences in operating systems, the example CellView dialogs shown in this chapter may vary slightly from the dialogs on your screen. However, the functions are the same. For example, you might use a button to enable a setting where the example shows a checkbox.

CellView Features

CellView enables you to:

- Configure signalling parameters
- Enable, disable, and configure up to four LAN Emulation Clients (LECs) and one IP-over-ATM client per adapter
- Set Permanent Virtual Circuit (PVC) communications with other end stations
- Enable, disable, and configure up to eight LAN Emulation Servers (LESs) and one IP-over-ATM ARP server per adapter
- Enable, disable, and configure one LAN Emulation Configuration Server (LECS) per adapter
- Display operating statistics for:
 - SONET, signalling, and cell-level activity
 - ATM Adaptation Layer 5 (AAL5) activity
 - LEC membership and activity
 - IP-over-ATM activity
 - LECS and LES activity
- Set parameters for displaying and updating CellView dialogs

ATM Address

During configuration, you will need to know the end station's unique ATM address, as shown in the ATM Address field in Figure 4-1:

ATM Address:	
47:00:00:00:dd:01:00:00:27:2a:84:00:00:77:86:da:61-00	
Network Prefix:	ESI/Selector:
47:00:00:00:dd:01:00:00:27:2a:84:00	00:00:77:86:da:61-00

Figure 4-1. ATM Address

The Network Prefix and ESI/Selector fields show the separate ATM address components.

The network prefix is the 13-byte link address of the adapter, as set by the ATM switch.

The ESI/Selector consists of a unique end station identifier (ESI) and a pointer (selector) with the following values:

- The ESI value is the 6-byte MAC address of the adapter (00:00:77:86:da:61 in the example).
- The Selector value is a 1-byte pointer to clients and services located in the end station (00 in the example).

The Selector value for the end station is always 00. The Selector values for the clients and services located in the end station are as follows:

Item Number	Range of Selector Values
LEC1 – LEC4	0x00–0x03
LES1 – LES8	0x20–0x27
BUS1 – BUS8	0x40–0x47

Configuration Requirements

The degree of configuration needed for the adapter(s) depends largely on whether the services are already installed on the network. For example, if the LECS, LESs, and ARP server are running elsewhere on the network, you need to enable and configure only the local clients.

At least one LEC or IP-over-ATM client must be enabled and fully configured on each adapter before running applications on the network.

Before you begin the configuration procedures described in this chapter, the following prerequisite requirements must be met:

- At least one adapter is installed in the end station.
- The driver for your operating system is installed.
- The machine has been rebooted after the driver installation.

If any of these tasks are not complete, please complete them now. See the appropriate chapter(s) or addendum(s) for instructions.

Starting CellView

The startup procedure for CellView depends on the operating system you are running. The following table describes the startup procedure for each operating system:

Operating System	CellView Startup Procedure
AIX	Enter the command <code>cellview</code>
HP-UX	Enter the command <code>cellview</code>

Chapter 4: Configuring the Adapter Using CellView

Operating System	CellView Startup Procedure
Solaris	Enter the command <code>cellview</code>
UnixWare	Enter the command <code>cellview</code>
IRIX	Add to your path: <code>/usr/sbin/</code> Enter the command <code>cellview</code>
SCO	Add to your path: <code>/etc/atm/bin</code> Enter the command <code>cellview</code>
Windows 95	Select Start . Select Programs . Select Control Panel . Double-click the CellView icon.
Windows NT 3.51	Go to the Main Group. Open the Program Manager . Open the Control Panel . Double-click the CellView icon.
Windows NT 4.0	Select Start . Select Settings . Select Control Panel . Double-click the CellView icon.

When you start CellView, the main dialog appears:

Starting CellView

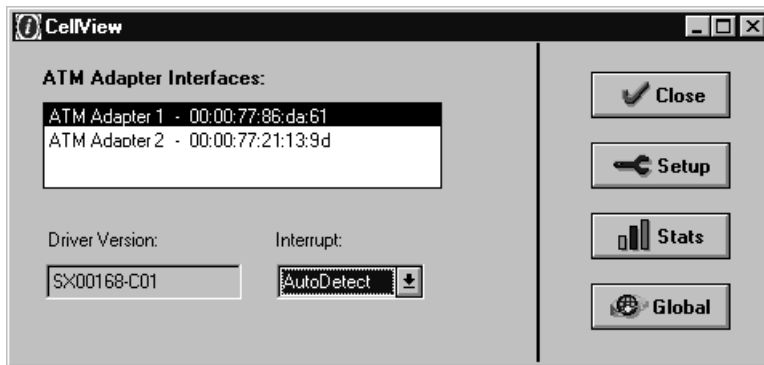

Figure 4-2. Main CellView Dialog



NOTE

If you are configuring a PCI or PMC ATM adapter under Windows NT, the main dialog contains a selection box for changing the PCI Interrupt value.

The main CellView dialog lists the adapter(s) installed in your computer and provides navigation buttons. All subsequent dialogs are *child* dialogs. The contents of each Setup and Statistics dialog apply to the adapter that is highlighted in the ATM Adapter Interfaces box.

The main CellView dialog provides the following selections:

Select...	To do this...
Interrupt (Windows NT only)	Set the PCI interrupt value for the adapter highlighted in the ATM Adapter Interfaces box. We recommend the default AutoDetect setting. If the driver fails to recognize the adapter with AutoDetect set, you might need to set a specific interrupt level.
Close	Exit CellView.
Setup	To configure: <ul style="list-style-type: none"> • Signalling • LECs • LESs (on the same adapter as the LECS) • LECS (on the same adapter as the LESs) • IP-over-ATM (1577) client and ARP server
Stats	To display the status of: <ul style="list-style-type: none"> • Signalling • AAL5 • LECs • LESs • LECS • IP-over-ATM (1577) client and ARP server
Global	To configure: <ul style="list-style-type: none"> • Applications (parameters for Setup and Stats dialogs) • Connection limits for end stations (display only) • Debugging (enable tracking of API, Signalling, ILMI)

Setup

The setting **Enable Advanced Settings**, which is located in the Application dialog of Global settings, controls whether the LECS and LES tabs appear for editing and viewing in the Setup and Stats routines. If Enable Advanced Settings is set to **OFF** (the default), the tabs do not appear.

Setup

Use CellView Setup dialogs to configure your adapter(s) for use on the ATM network. You can configure up to four LECSs and one IP-over-ATM client per adapter. The initial number of clients per adapter is specified during driver installation.

You can also configure one LECS and up to eight LESs per adapter for the ATM network. **If you will be enabling the LECS and LESs**, configure these before configuring clients.

Following is an overview of the CellView setup procedures to use to configure network services for each adapter in an end station. The topics in this section provide detailed information about each of these procedures.

1. On the main CellView dialog, highlight the adapter you are configuring, and select **Setup** to make dialogs available for setting up signalling, clients, and servers.
2. On the Signalling dialog, check that all signalling parameters conform to the capabilities of your ATM switch, and change settings, if needed.
3. **If the LECS and the LES(s) will be on this machine**, use the LECS and LES dialogs to configure these servers. (You might need to enable settings in the Global Application dialog to make these dialogs available.)

4. On the LEC dialog(s), configure the LECs specified for the adapter during driver installation.
5. On the 1577 dialog, configure the IP-over-ATM client and ARP server, if specified for the adapter during driver installation.
6. Exit CellView Setup.
7. **If you are running Windows NT**, exit CellView and reboot the machine.

The edits made with CellView are stored in a system file (`/etc/atm/cvconf`) on your hard disk. In Windows 95/NT systems, you must exit CellView and restart the machine to make these changes take effect. In UNIX-based systems, however, all changes to Setup dialogs, except UNI Signalling, are dynamic when you exit Setup. You can restart Signalling from the command line without rebooting the machine, as described on page 38, to make signalling changes take effect.

The following table shows where to find information about CellView Setup tasks:

For information about...	See page...
<i>Setting Up UNI Signalling</i>	36
<i>Setting Up LAN Emulation Clients</i>	38
<i>Setting Up IP-over-ATM Client and Server</i>	44
<i>Setting Up a LAN Emulation Configuration Server</i>	49
<i>Setting Up a LAN Emulation Server</i>	51

Setup

Setting Up UNI Signalling

The ATM adapter drivers are designed to operate with the UNI 3.0/3.1 signalling specification. All connections between two end stations are set up and torn down dynamically using SVC communications.

To set up UNI signalling parameters:

1. On the main CellView dialog, highlight the adapter you want to configure. Then select **Setup** to display the Signalling dialog:

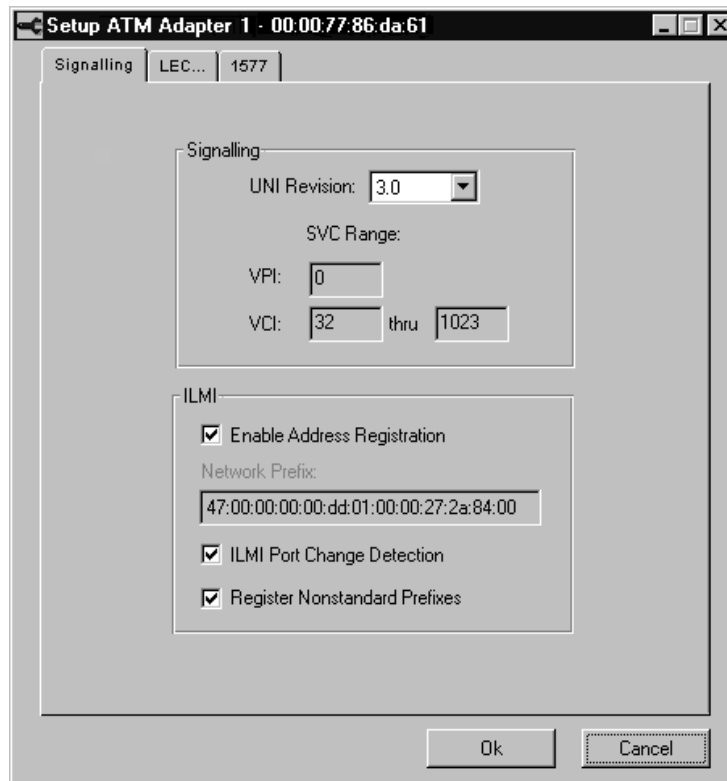

Figure 4-3. CellView Signalling Setup

2. Provide information in the Signalling dialog fields, as follows:

Use this field...	To do this...
UNI Revision	Select the UNI revision (UNI 3.0 or UNI 3.1).
SVC Range: VPI (Virtual Path Identifier)	Determine the VPI available to the driver for SVCs. The VPI is a one-byte field in the ATM cell header that, when combined with the VCI, forms an ATM address. Currently, only VPI 0 is supported.
SVC Range: VCI (Virtual Circuit Identifier)	Determine the range of VCIs available to the driver for SVCs. The range is fixed and cannot be edited. In the sample dialog (Figure 4-3 on page 36), circuits 0–31 are reserved for system communications. Circuits 32–1023 are available for station-to-station traffic.
Enable Address Registration	Enable the adapter to acquire its 13-byte network prefix at bootup from the switch. Disable this feature if your switch does not support address registration.
Network Prefix	Display or enter the adapter's 13-byte network prefix. If the Enable Address Registration feature is enabled, the network prefix is entered automatically at bootup, and is display-only. If the Enable Address Registration feature is disabled, obtain the network prefix from the switch and enter it manually.
ILMI Port Change Detection	Enable the adapter to poll the ATM switch every 30 seconds, to advise that it is up and running. At bootup, the switch adds the host station to the active stations list. If the host station is turned off, polling stops, and the switch removes the host from this list. Disable this feature if your switch does not support ILMI polling.

Setup

Use this field...	To do this...
Register Nonstandard Prefixes	<p>Enable the ILMI to register the ATM Forum's well-known address for the LECS with the switch. The prefix in the well-known address usually differs from the ATM prefix for the adapter. Some switches might not support the registration of different prefixes through a single port.</p> <p>Disable this setting if your switch does not support mixed prefixes.</p>

In UNIX-based systems, you must restart signalling for signalling setup changes to take effect.

- In IRIX operating systems, restart signalling with the command `sigd_start`
- In other UNIX operating systems, restart signalling with the command `restart_sigald`

Setting Up LAN Emulation Clients

CellView provides a separate tabbed LEC dialog for each LEC setup. Using the LEC dialogs, you can set parameters for each LEC to establish communications with an LECS at bootup, or to contact a LES directly. You can also set up PVC links with other end stations.

To set up a LEC:

1. On the main CellView dialog, highlight the adapter you want to configure.
2. Select **Setup**, and then select the **LEC...** tab.
3. Select the **LEC<x>** tab (where <x> is the number of the LEC you are configuring) to display the appropriate LEC dialog:

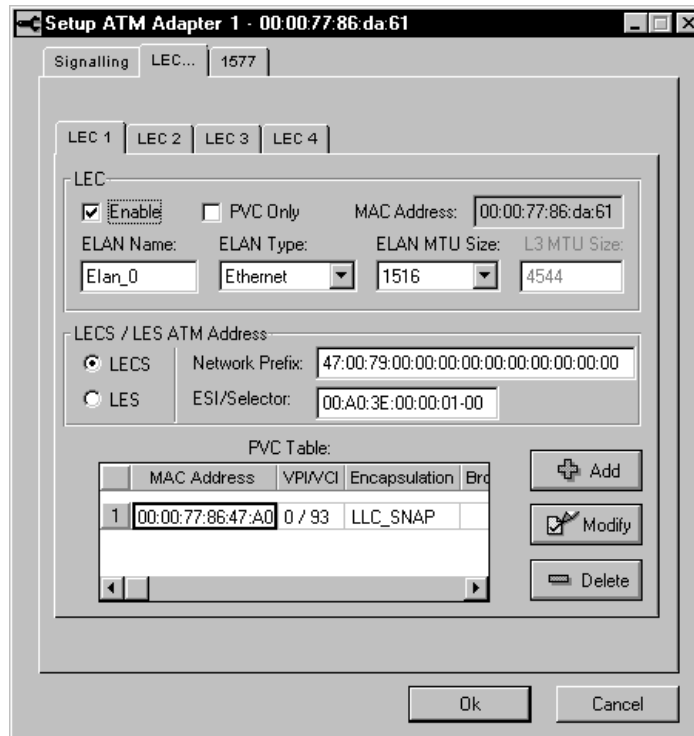

Figure 4-4. CellView LEC Setup

4. Enter information in the LEC dialog fields to configure the following:
 - LEC settings and LECS/LES ATM address settings
 - LEC PVC settings

The topics that follow provide information about configuring these settings.

Setup

LEC and LECS/LES ATM Address Settings

To configure LEC settings and LECS/LES ATM address settings, provide information in LEC dialog fields, as follows:

Use this field...	To do this...
Enable	Enable the LEC.
PVC Only	Set up PVC communications without enabling SVC activity. For PVC-only clients, the only other settings you need to configure are the L3MTU Size and the PVC Table.
MAC Address	View the MAC address of the LEC. LEC 1 is assigned the base address for the adapter. The remaining LECs use increments of the base address for their MAC addresses. If the LEC is enabled as Token Ring, the MAC Address is displayed in non-canonical format.
ELAN Name	Identify the network name of the emulated LAN that you want the client to join. Some configuration servers require a name while others do not. The Interphase LECS and LESs require a name only in the following cases: <ul style="list-style-type: none"> • The Strict ELAN Name field is enabled on the LES dialog. • You need to differentiate between two or more LESs with the same MTU size and ELAN type. For exact requirements, see your server documentation. For information about setting up Interphase servers, see <i>Setting Up a LAN Emulation Configuration Server</i> on page 49.
ELAN Type	Select the ELAN type (Ethernet or Token Ring).

Use this field...	To do this...
ELAN MTU Size	<p>Select the requested ELAN MTU size. The client uses this entry when making a request to join a LES. The MTU returned to the client is equal to or less than the requested value.</p> <p>Recommended settings are:</p> <ul style="list-style-type: none"> • ELAN with Ethernet edge device: 1516 • ELAN with Token Ring edge device: 4544 • ELAN with ATM end stations only: 9234 <p>All nodes on the same logical subnet must use the same MTU size.</p>
L3MTU Size	<p>Force the MTU size to the entered value, rather than the value returned by the LANE server (LES). Done only for values other than zero (0).</p> <p>If the client is in PVC-only mode (no LAN Emulation services), you must set the L3MTU size to the IP MTU of the network.</p> <p>If the MTU is not based on the MAC layer, you must set the L3MTU size to the actual IP MTU of the network. For example, if the ELAN MTU Size of a Token Ring network is 4544, but the IP MTU is 2048, set the L3MTU Size to 2048.</p>
LECS/LES ATM Address	<p>Select the mode of contact at bootup:</p> <ul style="list-style-type: none"> • LECS contacts the LES with the 20-byte ATM address in the Network Prefix and ESI/Selector fields. (The default address is the ATM Forum's well-known address.) • LES uses the 20-byte address in the ATM address fields to contact a LES directly.

Setup

LEC PVC Settings

Use the PVC Table in the LEC dialog to set up PVC connections between a client and other network end stations. Figure 4-5 illustrates the PVC Table for LECs:

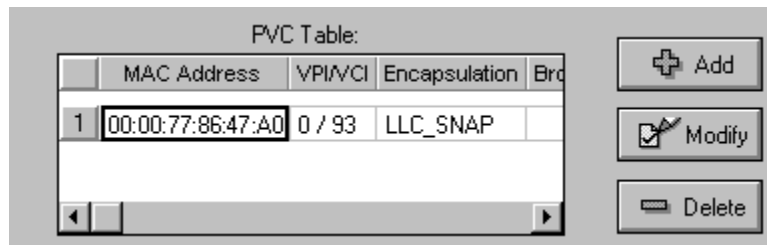

Figure 4-5. PVC Table in LEC Dialog

A 6-byte MAC address and a VCI number are associated with each PVC. Packets from the upper layers whose destination MAC addresses match an address in the PVC table are transmitted on that PVC.

In addition to providing setup information in the PVC Table, you must also consider the following when configuring PVCs for LECs:

- All PVCs must be configured in the adapters and the switch(es) manually.
- The MAC address of the target station must be mapped to a VCI in the local host.
- The MAC address of the local client must be mapped to a VCI in the target station.

You can use buttons in the PVC table block to add, modify, or delete PVC table entries, as described in the topics that follow.

Adding or Modifying LEC PVC Entries

To add or modify PVC table entries for the LEC:

1. Select **Add**, or highlight the appropriate entry and select **Modify**.

The following dialog appears:

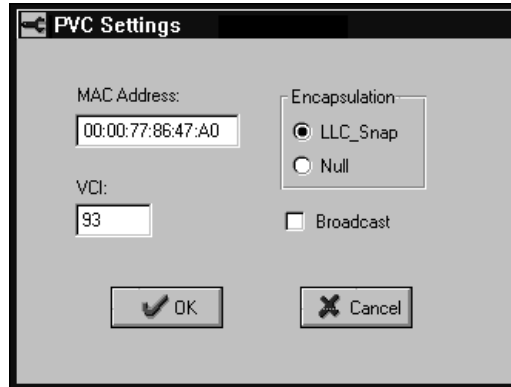

Figure 4-6. PVC Settings for LECs

2. Provide information in the PVC Settings dialog fields, as follows:

Use this field...	To do this...
MAC Address	Enter the 6-byte address of the target station. Use the natural format for the ELAN. For example, for a Token Ring ELAN, use non-canonical format.
VCI	Identify the VCI number that the LEC uses to communicate with the target. To determine the range of VCIs available, go to the Setup dialog for Signalling, and check the SVC Range in the VCI fields (Figure 4-3 on page 36). In most cases, the range is 32–1023. (The corresponding VPI cannot be edited and is fixed at a value of zero.)

Setup

Use this field...	To do this...
Encapsulation	Select the encapsulation method (LLC_Snap or Null). The host and target must use the same encapsulation method. See <i>Multiprotocol Encapsulation over ATM AAL5</i> on page 22 for an explanation of these encapsulation methods.
Broadcast	Enable the entry as a Broadcast PVC. If enabled, all broadcast/multicast packets from the upper layers are transmitted on this PVC. A maximum of 16 Broadcast PVCs can be enabled on each LEC.

Deleting LEC PVC Entries

To delete a PVC table entry, highlight the entry, and select **Delete**.

Setting Up IP-over-ATM Client and Server

The IP-over-ATM client conforms to the RFC-1577 specification using Classical IP-over-ATM where no multicast or broadcast services are available.

Using the 1577 dialog, you can enable the Classical IP-over-ATM client and enable the host adapter as the Address Resolution Protocol (ARP) server for the network. You can also set up PVC links with other end stations.

To set up an IP-over-ATM client/ARP server configuration:

1. On the main CellView dialog, highlight the adapter you want to configure.
2. Select **Setup**, and then select the **1577** tab to display the 1577 dialog:

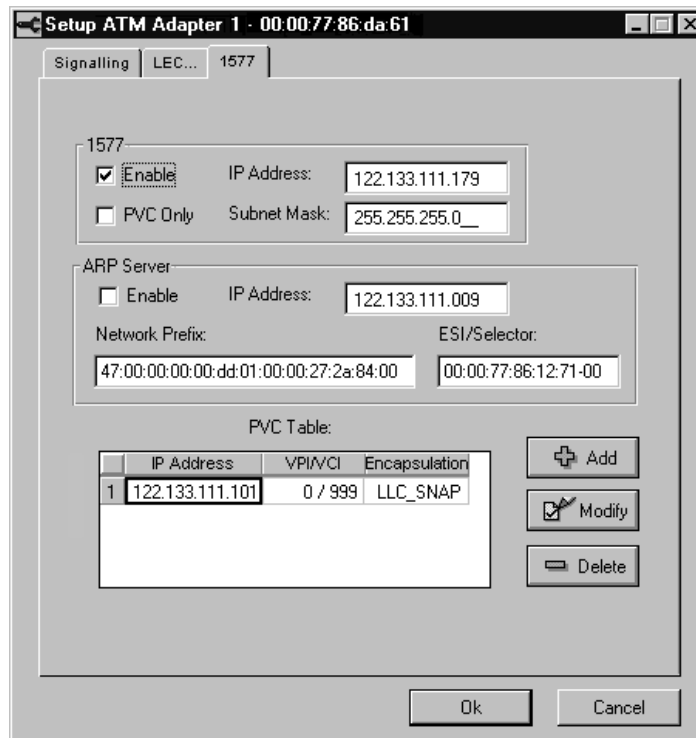
**Figure 4-7. CellView IP-over-ATM Setup**

3. Enter information in the 1577 dialog fields to configure the following:
 - IP-over-ATM client and ARP server settings
 - IP-over-ATM PVC settings

The topics that follow provide information about configuring these settings.

Setup

IP-over-ATM Client and ARP Server Settings

To configure IP-over-ATM client and ARP server settings, provide information in the 1577 dialog fields, as follows:

Use this field...	To do this...
Enable	Enable the Classical IP-over-ATM client.
PVC Only	Set up PVC communications without enabling the SVC activity. For PVC-only clients, the only other settings you need to configure are the PVC Table settings.
IP Address	Enter the client's IP address.
Subnet Mask	Enter the client's subnet mask identifier.
ARP Server: Enable	Enable the host adapter as the ARP server for your IP-over-ATM network.
ARP Server: IP Address	If the host adapter is not the ARP server, enter the IP address of the ARP server located elsewhere in the network.
ARP Server: Network Prefix and ESI/Selector	If the host adapter is not the ARP server, enter the ARP server's ATM address, which consists of the Network Prefix and ESI/Selector. (For details about the address structure, see <i>ATM Address</i> on page 29.) The IP-over-ATM driver must know the ATM address of the ARP server. When the system is powered up, it calls the ARP server with this ATM address.

IP-over-ATM PVC Settings

Use the PVC Table in the 1577 dialog to set up PVC connections between the local client and other end stations in the IP-over-ATM subnetwork. Figure 4-8 illustrates the PVC Table for IP-over-ATM clients:

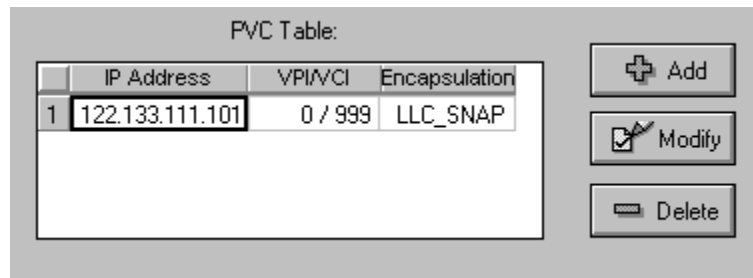

Figure 4-8. PVC Table in 1577 Dialog

In addition to providing setup information in the PVC Table, you must also consider the following when configuring PVCs for the IP-over-ATM client:

- All PVCs must be configured in the adapters and the switch(es) manually.
- The IP address of the target station must be mapped to a VCI in the local host.
- The IP address of the local client must be mapped to a VCI in the target station.

You can use buttons in the PVC table block to add, modify, or delete PVC table entries, as described in the topics that follow.

Adding or Modifying IP-over-ATM PVC Entries

To add or modify PVC table entries for an IP-over-ATM client:

1. Select **Add**, or highlight the appropriate entry and select **Modify**.

The following dialog appears:

Setup

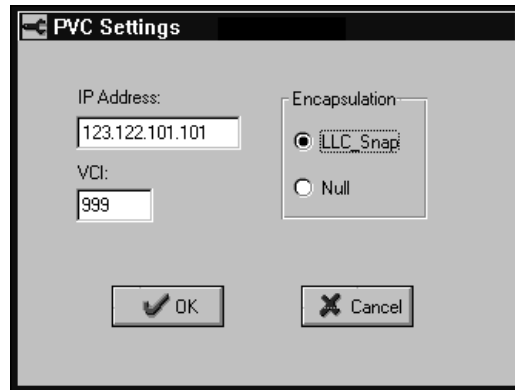

Figure 4-9. PVC Settings for IP-over-ATM Clients

2. Provide information in the PVC Settings dialog fields, as follows:

Use this field...	To do this...
IP Address	Enter the IP address of the target station.
VCI	<p>Identify the VCI number that the IP-over-ATM client uses to communicate with the target.</p> <p>To determine the range of VCIs available, go to the Setup dialog for Signalling, and check the SVC Range in the VCI fields (Figure 4-3 on page 36).</p> <p>In most cases, the range is 32–1023. (The corresponding VPI cannot be edited and is fixed at a value of zero.)</p>
Encapsulation	<p>Select the encapsulation method (LLC_Snap or Null). The host and target must use the same encapsulation method. See <i>Multiprotocol Encapsulation over ATM AAL5</i> on page 22 for an explanation of these encapsulation methods.</p>

Deleting IP-over-ATM PVC Entries

To delete a PVC table entry, highlight the entry, and select **Delete**.

Setting Up a LAN Emulation Configuration Server

To communicate on an ATM network, a LEC must join an emulated LAN (ELAN). The ELAN consists of a group of end stations that communicate among themselves with the same MTU size, the same frame format, and the same broadcast/multicast services. The LAN Emulation Server (LES) is the central server for the ELAN. The LAN Emulation Configuration Server (LECS) manages which LEC joins which LES.

The LECS must reside on the ATM adapter with the LESs it serves; it cannot communicate with LESs across the network. You must enable the LECS and associated LESs before configuring LECs that join LESs.

The LECS provides a central point of contact on the network for LECs at bootup. At bootup, the LEC sends the LECS a request for the type of ELAN it wants to join. The LECS responds with the current ATM address and the configuration parameters of the LES that serves the requested ELAN.

To set up the LECS:

1. If the LECS tab is not available, select **Global** from the main CellView dialog to display the Application Dialog. Then enable the **Enable Advanced Settings** field and click **OK**.
2. On the main CellView dialog, highlight the adapter you want to configure.

Setup

3. Select **Setup**, and then select the **LECS** tab to display the LECS dialog:

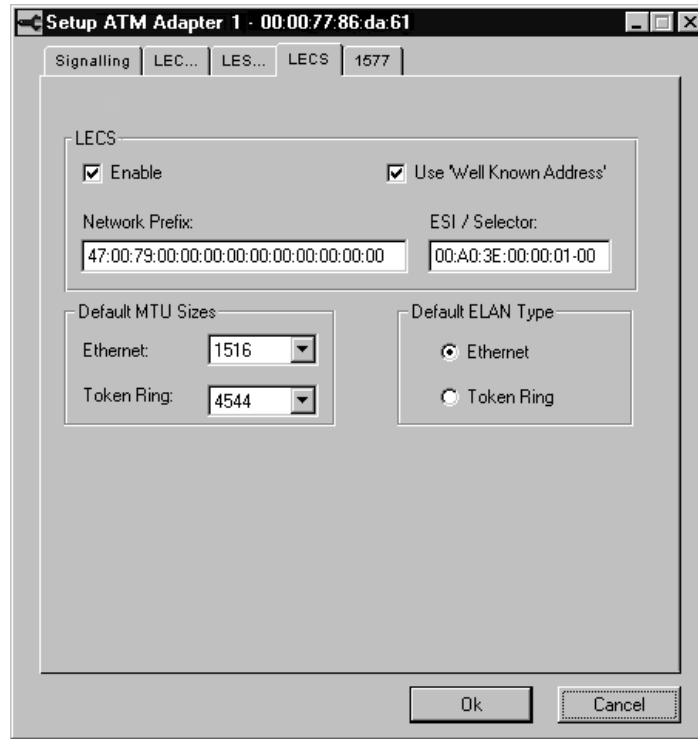

Figure 4-10. CellView LECS Setup

4. Provide information in the LECS dialog fields, as follows:

Use this field...	To do this...
Enable	Enable the LECS and all permanent mappings of LECs to specific LESs.

Use this field...	To do this...
Use 'Well Known Address'	Enable the ATM Forum's well-known address to be loaded to the Network Prefix and ESI/Selector fields. When enabled, these address fields cannot be edited.
Default MTU Sizes	Select the default Ethernet or Token Ring ELAN MTU size to assign to a LEC if the LEC's configuration request omits the MTU size. If the request also omits the ELAN type, the LECS will attempt to assign the LEC to a LES of the default ELAN type with an MTU size equal to or less than the requested size.
Default ELAN Type	Select a default ELAN type to assign to a LEC if the LEC's configuration request omits the ELAN type. The LECS will attempt to assign the LEC to a LES of the Default ELAN Type with an MTU size equal to or less than the requested size.

Setting Up a LAN Emulation Server

To communicate on an ATM network, a LEC must join an emulated LAN (ELAN). The ELAN consists of a group of end stations that communicate among themselves with the same MTU size, the same frame format, and the same broadcast/multicast services. The LAN Emulation Server (LES) is the central server for the ELAN. It provides address registration, address resolution, and broadcast services for all ELAN members. The LAN Emulation Configuration Server (LECS) manages which LEC joins which LES.

The driver allows up to eight LESs to be enabled per adapter at one time (allowing adapter support for up to eight ELANs). LESs must reside on the ATM adapter with the LECS that

Setup

serves them; they cannot communicate with the LECS across the network. You must enable a LES and its associated LECS before configuring LECs to join the LES.

When a LEC joins a LES, the MAC-ATM relationship of the client is registered with the LES. The LES maintains a running account of these addresses to resolve queries from ELAN members. The connection between the LES and each LEC is a permanent, open connection as long as the client is running.

The LES maintains a table of client information that it uses to provide address resolution services to the ELAN. When an end station is disconnected or turned off, the LES removes client(s) from the table automatically. Therefore, relocating an end station is a matter of physically moving the hardware and connecting it to the same or another ATM switch. At bootup, the client(s) rejoin the previous LES with a new ATM address.

CellView provides a separate tabbed LES dialog for each LES-ELAN setup.

To set up a LES:

1. If the LES... tab is not available, select **Global** from the main CellView dialog to display the Application Dialog. Then enable the **Enable Advanced Settings** field, and click **OK**.
2. On the main CellView dialog, highlight the adapter you want to configure.
3. Select **Setup**, and then select the **LES...** tab.
4. Select the **LES<x>** tab (where <x> is the number of the LES you are configuring) to display the appropriate LES dialog:

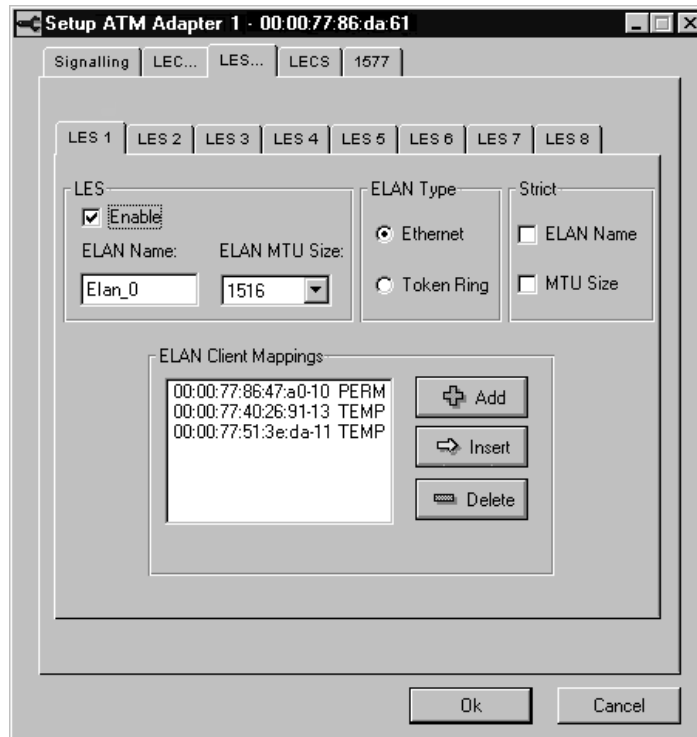

Figure 4-11. CellView LES Setup

5. Enter information in the LES dialog fields to configure the following:
 - LES settings
 - ELAN Client Mappings settings

The topics that follow provide information about configuring these settings.

LES Settings

To configure LES settings, provide information in the LES dialog fields, as follows:

Setup

Use this field...	To do this...
Enable	Enable the LES.
ELAN Name	<p>Enter the name of the ELAN for which the LES provides services (not required for a LEC to join the group).</p> <p>If the ELAN Name setting in the Strict block is enabled, the ELAN name in the LEC request must exactly match this name (case-sensitive). Otherwise, the server prevents the LEC from joining the group.</p>
ELAN MTU Size	<p>Select the MTU size for the ELAN for which the LES provides services. Recommended options are:</p> <ul style="list-style-type: none"> • ELAN with Ethernet edge device: 1516 • ELAN with Token Ring edge device: 4544 • ELAN with ATM end stations only: 9234 <p>If the MTU Size setting in the Strict block is enabled, the request from the LEC must exactly match the ELAN MTU Size. Otherwise, the server prevents the LEC from joining the group.</p>
ELAN Type	<p>Select the ELAN type (Ethernet or Token Ring) to use for all communications between end stations.</p> <p>If the ELAN includes an edge device to a legacy LAN, the ELAN type must be set to interface with that edge device.</p>
Strict: ELAN Name	Specify that the ELAN Name in the LEC's request must exactly match the entry in the ELAN Name text field on this dialog (case-sensitive).
Strict: MTU Size	Specify that the ELAN MTU Size in the LEC's request must exactly match the entry in the ELAN MTU Size selection field on this dialog.

ELAN Client Mappings Settings

The ELAN Client Mappings block of the LES dialog shows the ESI/Selector value for each LEC currently assigned to the LES. The clients can be *permanently* or *temporarily* assigned to the LES, based on settings configured in this LES dialog or in the LEC dialog. Figure 4-12 illustrates the ELAN Client Mappings block:

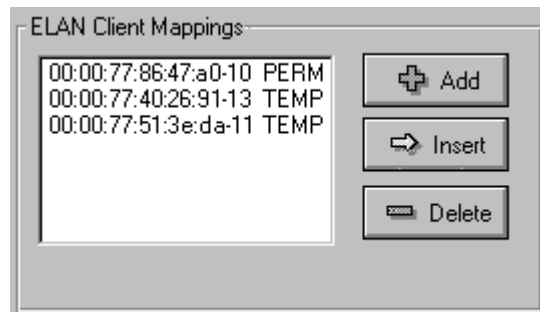

Figure 4-12. ELAN Client Mappings Table in LES Dialog

ELAN Client Mappings use two client classifications:

- **PERM** means the client is permanently assigned to the LES (using the Add or Insert button on this dialog). A permanently-assigned client can join only its assigned LES. This gives network administrators control in assigning clients to specific ELANs.
- **TEMP** means the client is temporarily assigned to the LES based on the configuration parameters requested by the client. This entry is removed when the client leaves the ELAN.

The ELAN Client Mappings table obtains the list of permanently-assigned clients from a table maintained by the LECS. When the LECS is enabled, it checks for a permanent

Setup

status each time a client attempts to join the network, regardless of whether the client is configured to contact the LECS or directly contact a LES.

Use the ELAN Client Mappings block of the LES dialog to permanently assign or remove LES client assignments.

Both the Add and Insert buttons in the ELAN Client Mappings block enable you to permanently assign clients to the LES.

- Use the **Add** button to enter the client's ESI/Selector value.
- If the client is currently assigned or running on another ELAN, it is more convenient to use the **Insert** button to move the client to this LES.

You can permanently assign a client that is permanently assigned to another LES, temporarily assigned to another LES, or currently not a member of any ELAN.

Adding a Client

To add a client to a LES:

1. Select **Add** to display the following dialog:

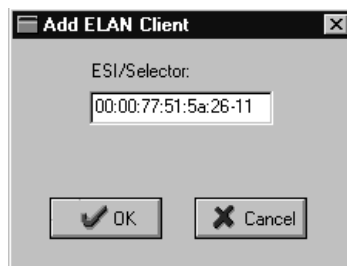

Figure 4-13. Add Permanent Clients to a LES

2. Enter the ESI/Selector value for the client.

If you are not familiar with the structure of this address, see *ATM Address* on page 29.

3. Select **OK**.

This procedure permanently adds the new entry to the LES's ELAN Client Mappings table. Also, if the client was a member of another ELAN, this procedure removes the client from that ELAN's LES. When the client attempts to join the network again, it can join only the newly-assigned LES.

Inserting Clients

To move clients from another LES to the LES being configured:

1. Select **Insert** to display the following dialog:

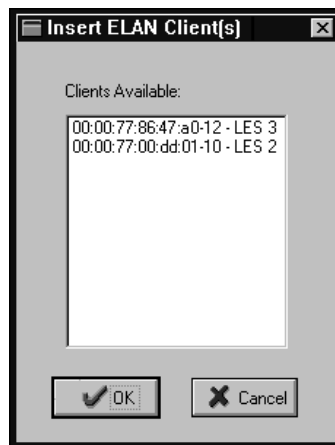

Figure 4-14. Insert Permanent Clients

This dialog lists all permanent and temporary clients that are assigned to other LESs.

2. Highlight the clients you want to move to the LES being configured, and select **OK**.

This procedure permanently adds the new entries to the LES's ELAN Client Mappings table and removes the client from other LESs.

Statistics Information

Deleting a Client

To remove a client from the LES, highlight the client in the ELAN Client Mappings block, and select **Delete**.

If the client was permanently assigned, it is removed from the ELAN served by the LES and from the table of permanent clients maintained by the LECS. It can attempt to join the network again any time after deletion.

If the client was temporarily assigned, it is removed from the ELAN served by the LES. When it attempts to join the network again, it will be assigned to a LES based on requested parameters. (This will be the same LES unless changed in the LEC Setup dialog since the last startup.)

Statistics Information

The dialogs in the CellView Statistics group provide statistics about installed adapters that can help you check for proper driver operation and troubleshoot network problems.

To see statistics about an installed adapter, select the adapter on the main CellView dialog, and then select **Stats**. To see statistics for an LECS or LESs located on an adapter, you might first need to make the LECS and LES tabs available in the Statistics group. To do so, on the main CellView dialog select **Global**; then select the **Application** tab and enable the **Enable Advanced Settings** feature.

Verifying Driver Installation

You can use information in the Statistics dialogs to verify that the driver is up and running properly. When the end station boots up, certain systems communications must occur between

the client and the server (through the switch) so the client can log on to the network. Statistics routines monitor the state of client and server traffic, as well as signalling and AAL5 traffic.

To do a quick check of an adapter's operating statistics:

1. Start CellView.

For instructions, see *Starting CellView* on page 30.

2. On the main CellView dialog, if more than one adapter is installed in the machine, select an adapter.

3. Select **Stats**, and check the following indicators in the Signalling dialog:

- All three graphical LEDs in the Signalling State box should be green.
- The ILMI, QSAAL, and Signalling fields in the State Detail box should have values similar to:
ILMI: ILMI Registered
QSAAL: Data transfer ready
Signalling: Signalling ready
- The Signalling Statistics box for both Frames In and Frames Out should indicate traffic.

4. Select the **AAL5** tab, and check the following indicators:

- All six graphical LEDs in the SONET box should be green.
- The AAL5 Statistics box should indicate traffic.

5. For each LEC enabled on the adapter, select the **LEC** tab, and check the following indicators:

- The LEC graphical LED should be green.
- The Tx Packets and Rx Packets fields of the display boxes should indicate traffic.

Statistics Information

6. If the IP-over-ATM client is enabled, select the **1577** tab, and check the following indicators:
 - The 1577 graphical LED should be green.
 - The 1577 Statistics fields should indicate traffic.
7. If more than one adapter is installed in the machine, repeat steps 2 through 6 for each additional adapter.

If you find an item in error, the driver might be incorrectly installed or configured. If you suspect a problem with your driver setup, see *Network Problems* on page 72.

Troubleshooting

You can use the Statistics dialogs to provide helpful information when you contact Interphase support personnel concerning ATM network problems. Statistics dialogs display network statistics gathered by CellView, such as signalling and traffic information, for the clients and servers on the adapter(s) installed in an end station.

CellView gathers network operation statistics for local Interphase clients and servers only. It does not gather statistics from switches or from other end stations.

For additional information about using Statistics dialogs to troubleshoot network problems, see *Network Problems* on page 72.

Global Settings

Settings for global routines control CellView parameters that are common to all adapters. You are not required to restart end stations to make global settings take effect. Use Global settings to:

- Control application display settings
- Display signalling connection settings in drivers
- Produce information to use for debugging

The following table shows where to find information about CellView Global tasks:

For information about...	See page...
<i>Controlling Application Display Settings</i>	61
<i>Displaying Signalling Connections Settings</i>	63
<i>Producing Debugging Messages</i>	64

Controlling Application Display Settings

Use the Application dialog to control display settings for CellView Setup and Statistics routines, such as refresh rates and tabbed dialogs available for setup and statistics routines.

To control display settings:

1. From the main CellView dialog, select **Global** to display the Application dialog:

Global Settings

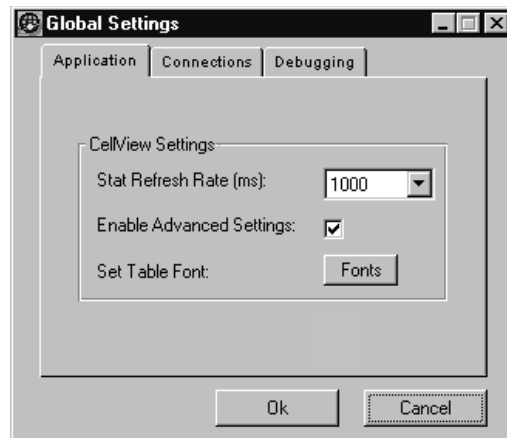

Figure 4-15. CellView Global Application

2. Provide information in Application dialog fields, as follows:

Use this field...	To do this...
Stat Refresh Rate	Control the update or refresh rate, in milliseconds, of the data fields in the Statistics dialogs.
Enable Advanced Settings	Activate the tabs for the LECS and the LES in the Setup and Statistics dialogs. This setting does not affect the enable/disable condition of the ELAN servers. The tabs can be hidden from view while the servers remain enabled.
Set Table Font	Select the font used for tables in dialogs.

Displaying Signalling Connections Settings

Use the Connections dialog to display the signalling connections configuration in adapter drivers. Currently, these settings cannot be changed; they are preset in the drivers.

To display the Connections dialog, select **Global** from the main CellView dialog, and then select the **Connections** tab:

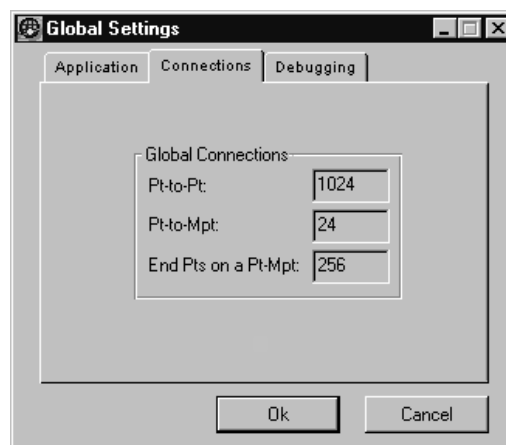

Figure 4-16. CellView Global Connections

The following table describes Connections dialog fields:

Use this field...	To do this...
Pt-to-Pt	Display the maximum number of SVC connections with other end stations that are allowed simultaneously.
Pt-to-Mpt	Display the maximum number of SVC multipoint connections that are allowed simultaneously. These are used primarily between LECs and a LES/BUS.
End Pts on a Pt-Mpt	Display the maximum number of end points on each multipoint connection. This affects the number of clients allowed on the same ELAN.

Producing Debugging Messages

Use the Debugging dialog as a troubleshooting aid for the adapter. If you have difficulty establishing connections with other network nodes or establishing ILMI connectivity with the switch, enable the appropriate debug options. The debug options produce signalling debug messages from various modules to help isolate the problem. Be sure to disable the options when debugging is complete.

To produce Debugging messages:

1. From the main CellView dialog, select **Global**, and then select the **Debugging** tab.



Figure 4-17. CellView Debugging Options

2. Select Debugging dialog options, as follows:

Use this field...	To do this...
API	Track the Signalling Application Program Interface (API). These are the routines used by the application software to manage SVCs.

Chapter 4: Configuring the Adapter Using CellView

Use this field...	To do this...
Signalling	Track the Signalling PDUs exchanged by the host Signalling and the switch.
ILMI	Track the IME PDUs exchanged by the host Signalling and the switch. Useful in debugging ILMI Address Registration problems.

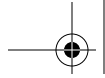

Global Settings

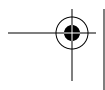
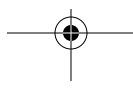

Verification and Troubleshooting

5

Overview

This chapter provides possible solutions for common problems encountered while installing and operating the SBus ATM adapter. If you experience a problem, first make sure that you have carefully followed the steps for installing the hardware and the software, and that you have rebooted the system. Also, check the console log on your system to see whether any error, have been logged.

In addition, if the source of the problem seems to be at the ATM switch, check your ATM switch documentation for port management tools that might aid the troubleshooting process.

If the information in this chapter or in your ATM switch documentation does not resolve the problem, see the assistance information at the front of this users guide.

Interpreting LEDs

The adapter has two LEDs:

- Green Link LED
- Yellow Status LED

Figure 5-1 shows the LEDs for adapters that use an SC Duplex connection:

Interpreting LEDs

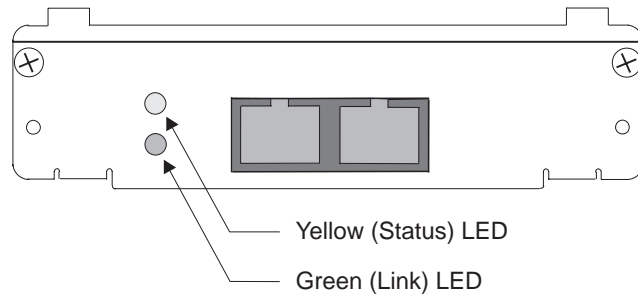

Figure 5-1. LEDs for Adapter with SC Duplex

Figure 5-2 shows the LEDs for adapters that use an RJ-45 type connection:

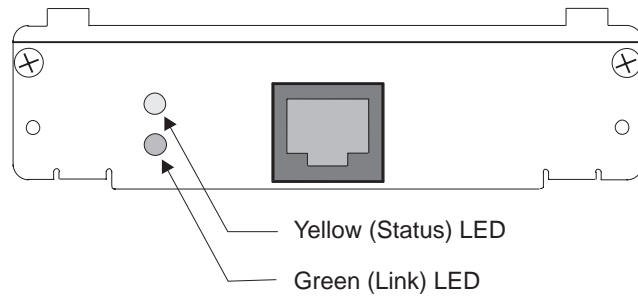

Figure 5-2. LEDs for Adapter with RJ-45 UTP

You can interpret these LEDs using the information in the following table:

This LED...	In this State...	Means...
Link	Off	The adapter is not receiving a signal from a switch or remote system.
Link	Solid Green	The adapter is receiving a signal from a switch or remote system.
Status	Off	The adapter does not have power.
Status	Solid Yellow	The adapter has power.
Status	Flashing Yellow	The driver is loaded.

The green Link LED indicates the condition of the physical link between the adapter and the ATM switch. When the green LED is lit, light or electrical current is flowing between the two sets of hardware; however, data may or may not be flowing through the cable.

The yellow Status LED serves two functions. When the machine is turned on, the LED glows a solid yellow to indicate that the adapter has power. Then it begins flashing to indicate that the software driver is loaded.

Problems and Possible Solutions

This section presents possible solutions for the following types of adapter problems:

- Link and status problems
- Bootup problems
- Network problems

Link and Status Problems

Problems indicated by the Link and Status LEDs might be related to hardware failure, inadequate power access, or improper driver installation.

Problem	Possible Solutions
Link LED not lit	<p>A failure in the hardware is preventing the adapter from completing a physical link with the switch.</p> <ol style="list-style-type: none"> 1. Check the switch. It must be up and running for the adapter to make a link. 2. Unplug and reinstall the connectors. 3. If this does not work, try a known good cable. 4. Check the transmit and receive wiring to see if they are reversed. For fiber connections, see Figure 2-8 on page 16. For UTP connections, see Figure 2-9 on page 16. 5. If a known good cable is installed, try another adapter in the expansion slot. <p>If the green LED does not illuminate, the problem is probably at the switch. Confirm this by configuring the cable to another port on the switch.</p>
Status LED not lit	<p>Power is not getting to the adapter.</p> <ol style="list-style-type: none"> 1. Do a power reset of the computer by turning the power off and then on again. 2. Make sure the adapter is seated correctly in the expansion slot. Check for a bent pin or crack in the connector. 3. Try another expansion slot. 4. Try another adapter known to operate correctly.

Problem	Possible Solutions
Status LED lit, but not flashing	<p>The driver is not installed, or the driver is not installed correctly.</p> <ol style="list-style-type: none"> 1. If the driver is not installed, install it. 2. If the driver is installed, check your system's console log to see if any errors were recorded during bootup that pertain to the ATM driver. This may provide some insight to the problem. 3. Reinstall the driver if it is not installed correctly.

Bootup Problems

Bootup problems are usually hardware related. For example, the adapter is located in the wrong slot, or the bus address is incorrect or in conflict with another device. If the machine worked properly before the adapter was installed, then the problem is probably with the adapter or with the hardware that was removed and replaced during installation of the adapter.

Problem	Possible Solutions
Computer does not boot up	<ol style="list-style-type: none"> 1. Check to see if the adapter is properly seated in the expansion slot. Reseat the adapter and restart the machine. 2. Try a different expansion slot. 3. Remove the adapter and reboot the system. If the system boots up and returns to a normal state, the adapter is probably defective. Confirm this by installing an adapter that is known to work correctly.

Problems and Possible Solutions

Problem	Possible Solutions
Host adapter not found	<p>The system cannot find or does not recognize the adapter.</p> <ol style="list-style-type: none"><li data-bbox="643 573 1198 730">1. If this is your first bootup since installing the adapter, the configuration registers may not match what the system expects. Instead of rebooting the system, turn the power off and then on again to reset all components to an initial state.<li data-bbox="643 741 1198 867">2. The adapter might be installed in the wrong slot. Make sure the adapter is in the slot for which the driver is configured. See your system manual(s) for the location of the expansion slots.<li data-bbox="643 877 1198 940">3. Make sure the adapter is seated correctly in the slot.<li data-bbox="643 951 1101 982">4. Try another expansion slot, if available.<li data-bbox="643 993 1149 1056">5. Try another adapter that is known to operate correctly.<li data-bbox="643 1066 1198 1192">6. Check the console log on your system to see if any errors were recorded during bootup that pertain to the ATM adapter or driver. This may provide some insight to the problem.

Network Problems

The procedures in this section assume the host workstation is up and running, the driver is loaded (yellow Status LED is flashing), and the adapter has formed a physical link (green Link LED is lit) with the switch. For more information, see *Interpreting LEDs* on page 67 and the previous section, *Bootup Problems*.

Most of the problems discussed in this section concern getting the clients up and running, and logged on to the network. In all cases, check the console log on your system to see if the clients are being rejected by the LECS or the LES. For the client to have any form of communication with a server:

- The switch must be configured correctly.
- Signalling must be up and running.
- The adapter must be assigned a network prefix.
- At least one client must be enabled.
- At least one LES must be present on the network.

The Debugging options in the Interphase CellView utility are an excellent tool for troubleshooting the adapter and network-related problems. Messages are logged from various modules to assist in isolating the problem. (Be sure to disable the options when debugging is complete so that debugging output does not continue to print to the screen.)

See *Producing Debugging Messages* on page 64 for additional information about CellView debugging options.

Problems and Possible Solutions

Problem	Possible Solutions
<p>Driver loads at bootup, but network clients are not connecting.</p>	<ol style="list-style-type: none"> 1. Use CellView to check the state of signalling. <ol style="list-style-type: none"> a. Select Stats from the main dialog. b. Select the Signalling tab. c. If the graphical LEDs for Signalling in the Statistics dialog are green, then signalling is up and running. See the next Problem item in this table. d. If the graphical LEDs are red, exit to the main dialog and select Setup. e. Make sure the setting in the UNI Revision field is set to coincide with the UNI setting in your switch. 2. Use CellView to check the hardware. <ol style="list-style-type: none"> a. Select Stats from the main dialog. b. Select the AAL5 tab. c. If one or more of the graphical LEDs in the SONET box is red, a failure occurred somewhere in the cable or connectors. 3. Use CellView to track communications between the adapter and the ATM switch. <ol style="list-style-type: none"> a. Select Global from the main dialog. b. Select Debugging. c. Enable the Signalling and ILMI options. <p>CellView tracks communications between the adapter and signalling in the switch, as well as the protocols used to monitor all other traffic. Check the messages in the console log on your system.</p> <p>When network debugging is complete, disable CellView Debugging options to stop further debugging output to the screen.</p>

Problem	Possible Solutions
<p>Signalling is running, but network clients are not connecting</p>	<p>Check the Network Prefix for the adapter.</p> <ol style="list-style-type: none"> 1. From the main dialog select Stats. A 13-byte address must be in the Network Prefix field. If not, the switch is configured incorrectly or the signalling setup for the adapter is in error. 2. Exit to the main dialog and select Setup. 3. Make sure the settings for the Enable Address Registration, the ILMI Port Change Detection, and the Register Nonstandard Prefixes coincide with the capabilities of your LAN Emulation services. <p>If automatic address assignment is not supported by the switch, the 13-byte address must be entered manually in the Network Prefix field.</p>
<p>Signalling and Address Registration are working, but network clients are not connecting</p>	<p>Check the settings for the client.</p> <ol style="list-style-type: none"> 1. From the main dialog select Setup/LEC/LEC#. 2. Make sure the LECS/LES parameters are specified correctly. These concern settings and parameters that must coincide with the capabilities of your switch. 3. The MTU size must be equal to or greater than the setting for an LES. For example, if only one LES is enabled with an MTU of 9K and the client attempts to join with an MTU of 1516, the client will be rejected. 4. Check the other settings in the dialog and make sure they coincide with at least one of the enabled LESs.

Problems and Possible Solutions

Problem	Possible Solutions
A network application no longer works	<ol style="list-style-type: none">1. If the application program worked prior to the installation of the adapter, a hardware conflict probably occurred. Some programs that access the hardware can cause a conflict at some point. This typically happens with hardware such as printers and modems.2. Use CellView to track the API (Application Program Interface).<ol style="list-style-type: none">a. Select Global from the main dialog.b. Select Debugging.c. Enable the API option.CellView tracks the lower level functions of the API. These are the routines used by the application software to manage or obtain system resources. Check the messages in the console log on your system. If no messages are being recorded, reboot the machine, run the application again, and check the message log again.<p>When network debugging is complete, be sure to disable CellView Debugging options to stop further debugging output to the screen.</p>

Specifications

A

4615 Adapter Specifications

Item	Specification
Memory	1 MB
Host Bus Interface	Fully compliant with SBus specification, Version B.0 (with 32-bit and 64-bit interfaces)
Network Interface	155 Mbps SONET OC-3c multimode fiber 155 Mbps SONET OC-3c single-mode fiber
Standards Compliance	IEEE 1496 ATM Layer CCITT I.361, ANSI T1S1/92-002R3 ATM Adaptation Layer AAL 5 LAN Emulation ATM Forum LANE 1.0 ATM signalling UNI 3.0/3.1
Diagnostics	LEDs: <ul style="list-style-type: none"> • Green "Live incoming link" • Yellow "status"
Data Transfer	DMA 80 MBps in 32-bit burst mode 160 MBps in 64-bit burst mode
Operating Power	10 W (2.0A @ 5V)
Interrupts	Default SBus level: 4
Mechanical	Length: 160.67 mm; Height: 19.64; Width: 83.82 mm

Operating Environment

Item	Specification
Network Connections SC Duplex (155 Mbps)	Single Mode Fiber (8.5/125) Maximum cable length: 15 km Minimum cable length: 3 m Multimode Fiber: (62.5/125): Maximum cable length: 2 km Minimum cable length: 3 m
RJ-45 (155 Mbps)	Category 5 UTP Copper Maximum cable length: 100 m

Operating Environment

Temperature	0–55° C / 32–131° F
Relative humidity	10–95% noncondensing
Altitude	0–15,000 feet

Storage Environment

This section assumes the adapter is stored in its original anti-static bag and box.

Temperature	-20–85° C / -4–185° F
Relative humidity	10–95% noncondensing
Altitude	0–50,000 feet

Updating the Adapter's FCode

B

Installing FCode Updates

The 4615's onboard flash memory contains the adapter's FCode. As updates to the FCode are released, you can download the new image using the `iaparam(8)` utility. Updates will be available on a diskette. After the executable file is loaded from the diskette to some directory on the system, type the following command to install the new FCode:

```
iaparam -f ia.bin
```

where `ia.bin` is an example of the filename from the diskette.

To activate the update, reboot the system.

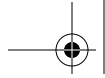

Installing FCode Updates



ATM Technology Overview

C

Introduction to ATM

Asynchronous Transfer Mode (ATM) is a switched, connection-oriented technology that allows voice, data, images, and video to be sent over the same network media. With significantly higher bandwidths than legacy LANs such as Ethernet and Token Ring, ATM supports applications such as multimedia and teleconferencing with a quality of service that is unavailable from other networks.

In addition, ATM can be scaled down to interface with a wide range of existing network configurations, as shown in Figure C-1. This flexibility is a result of ATM's inherent scalability, which extends from desktops to supercomputers.

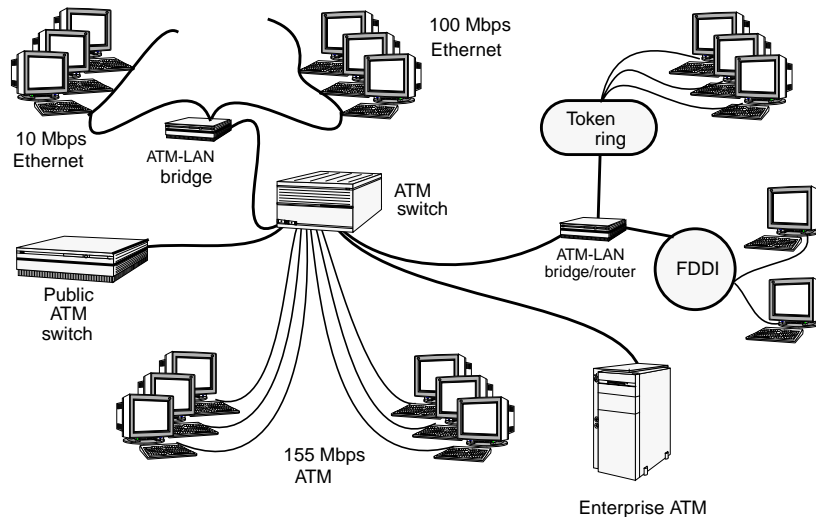

Figure C-1. ATM Network Topology

Virtual Circuits

The core concept of ATM is cell switching. Cell switching combines the benefits of packet switching, as used in traditional data networks, with circuit switching, as used in voice communications.

With ATM, all data, voice, and video information is converted into small, fixed-length packets, called *cells*, of 53 bytes each. These cells provide a standard way to combine the transmission rates required by bursty, variable-length packets of data and images with the constant, average rates required by voice and full-motion video. Transmitting fixed-length cells virtually eliminates the traditional overhead delays encountered with variable-length packets.

Virtual Circuits

ATM uses *virtual circuits (VCs)* to create individual communication links between network nodes for transporting the 53-byte fixed-length cells. These virtual circuits carry all transmissions between nodes. They maintain the correct cell sequence throughout the length of the transmission and provide a defined Quality of Service (QoS).

ATM networks use two types of virtual circuits:

- Permanent virtual circuits (PVCs)
- Switched virtual circuits (SVCs)

The path or connection used by virtual circuits is the *virtual circuit connection (VCC)*.

Virtual Circuit Connections

A virtual circuit connection (VCC) is a path or connection between any source and any destination in the ATM network. A VCC between two stations is configured manually for

PVCs, and dynamically, via signalling, for SVCs. All communication between the two stations proceeds along the same VCC.

The ATM cell header's virtual circuit identifier (VCI) is assigned per network VCC link, that is, end station-to-switch, switch-to-switch, switch-to-end station, and so on.

The *virtual path* (VP) creates groups of the VCs carried between the ATM entities, such as the ATM switches shown in Figure C-2:

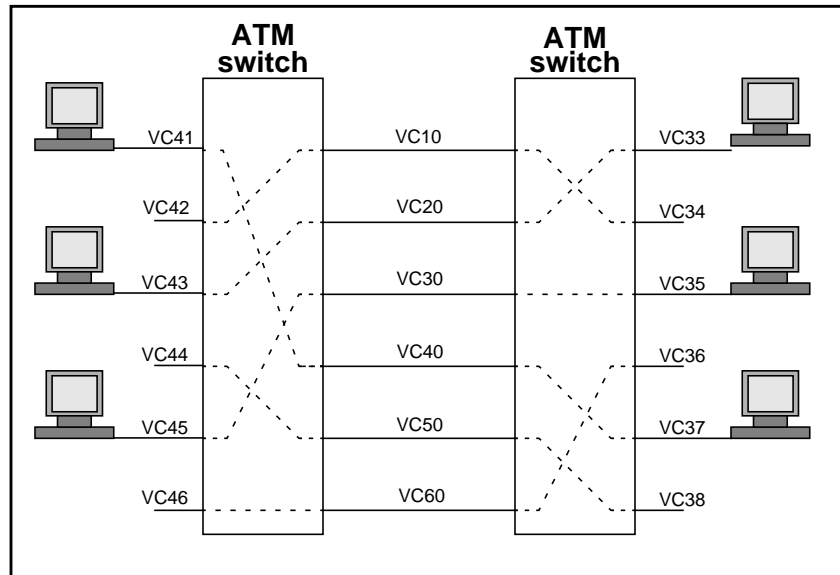

Figure C-2. Virtual Circuits

The VCs associated with a VP are globally switched without unbundling or processing the individual VCs. Thus, the cell-carrying capacity of each VC is preserved, and the quality of service of the VP can be scaled to extremely high speeds.

Permanent Virtual Circuits

Permanent virtual circuits (PVCs) are permanent, static connections between network nodes. With PVCs, the nodes operate as if they are connected with a dedicated physical line.

PVCs must be configured manually. To implement PVCs in an ATM network, you must create individual tables at each station and a master table at the switch. The table for each station must list the VCIs that identify the first steps in the paths leading to other stations with which the station is to communicate. At the switch, the master table must link all the information in the individual station tables.

When you move a station, you must recreate its table and also recreate its information in the switch's master table so that the station can reconnect to the network.

Switched Virtual Circuits

Switched virtual circuits (SVCs) are similar to voice telephone network connections; temporary connections between any two end points on the network are created dynamically for each session and torn down when the information exchange is complete. SVCs are created by signalling software in the end stations and the switches. This dynamic configuration eliminates the manual work required to implement PVCs.

With SVCs, the ATM switch only has to identify the output port to which to route a received cell and identify the new VPI/VCI on the output link.

Fixed-Length Cells

Fixed-length cells of 53 bytes each are transmitted over the VC established between the sending node and the receiving node. As shown in Figure C-3, each cell contains the following:

- A 5-byte header for connection identification, flow control, routing, and error control
- 48 bytes of data

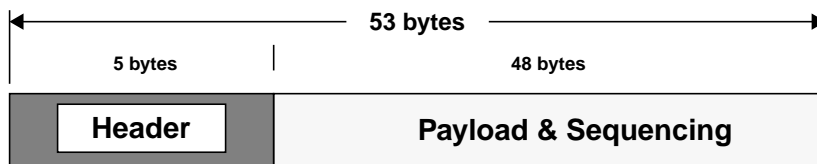

Breakdown of 5-byte Header

	Bits 0-3	Bits 4-7
Byte #1	GFC/VPI*	VPI
Byte #2	VPI	VCI
Byte #3	VCI	
Byte #4	VCI	Payload Type
Byte #5	Header Error Control	

GFC: Generic Flow Control **VPI:** Virtual Path Identifier
VCI: Virtual Circuit Identifier **CLP:** Cell Loss Priority bit

* First 4 bits are used as GFC field in the case of User-Network Interfaces.

Figure C-3. The ATM Cell

Scalability

The fixed-byte count allows fast hardware switching, lowers processing requirements, and practically eliminates the overhead associated with processing variable-length packets. As a result, ATM cells can be transmitted through multiple, contiguous connections and still maintain the time-sensitive quality of service required for audio and video applications.

Scalability

A major benefit of ATM is its inherent ability to support many different access and transmission speeds on different physical media. This is referred to as *scalability*.

For example, a cell generated on a 155 Mbps ATM LAN can be carried over a 45 Mbps asynchronous DS3 line to a network in a different location. From there, the cell can be switched into a 2.4 Gbps SONET (synchronous) transport system.

ATM networks can allocate a guaranteed amount of bandwidth for fixed-bit-rate, delay-sensitive transmissions such as video and voice data. And they can allocate a variable amount of bandwidth for the balance of network data that is less delay-sensitive.

ATM Layers

The B-ISDN (Broadband Integrated Services Digital Network) model defines three ATM layers:

- Physical Layer
- ATM Layer
- ATM Adaptation Layer (AAL)

In comparison with the OSI model, the three ATM layers are similar to the Physical Layer (Layer 1) and a portion of the Data Link Layer (Layer 2):

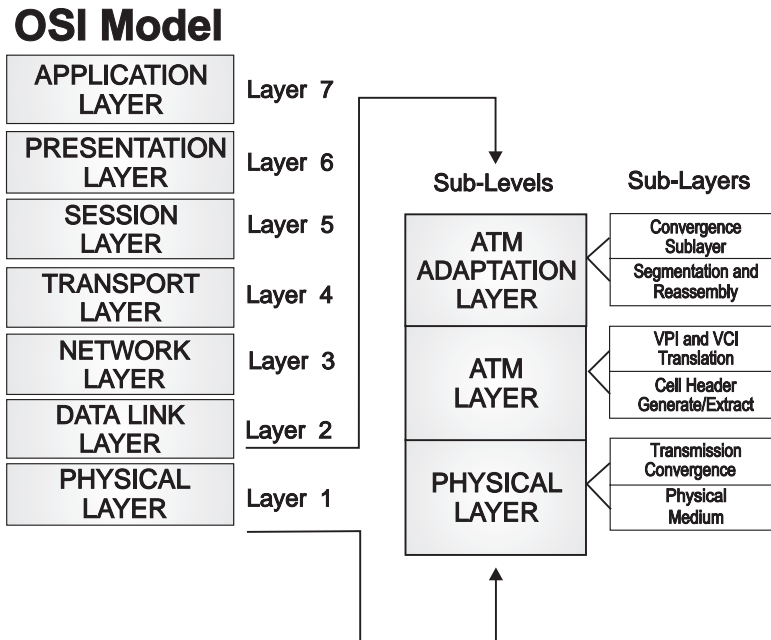

Figure C-4. ATM Compared to the OSI Model

Physical Layer

The ATM Physical layer defines the interface and framing protocol for the ATM network. The ATM Physical layer has two sublayers:

- The PMD sublayer provides bit transfer functions that are specific to the medium used in the network.
- The TC sublayer controls the transmission of frames over the physical medium.

ATM Layer

The ATM Layer defines the cell structure and how cells move between connections in an ATM network. This layer creates the cells and controls the setup and teardown of virtual connections and virtual paths in the network.

ATM Adaptation Layer

The ATM Adaptation layer (AAL) enhances the services provided by the ATM layer to better serve the next higher layer's functions. It provides timing and sequencing information tailored to the upper layer it is working with. It converts this information and the data being sent to ATM cells according to its rules. It then converts the ATM cells back to data after they reach their destination.

AAL is classified into four classes of service. For each class, AAL consists of two sublayers. The different service classes vary in the form of data transfer they support and in their sublayer structures.

AAL Service Classes

The currently defined AAL service classes are:

- AAL1
- AAL2
- AAL3/4
- AAL5

AAL1

AAL1 service supports the transfer of constant bit rate (CBR) data and provides mechanisms for maintaining timing and structure information for that data. It is primarily intended for transporting small data samples, such as voice.

AAL2

AAL2 service is not yet standardized. Its definition is currently under development by the ITU.

AAL3/4

AAL3/4 service supports the transfer of data that is sensitive to cell loss, but less sensitive to delay than AAL1-type data. AAL3/4 segments upper-layer data into cells, each of which consists of:

- A 2-octet header
- 44 octets of protocol data unit (PDU) payload
- A 2-octet trailer

The header and trailer provide message- and cell-level sequencing, as well as per-cell CRC. This cell-level management comes at the cost of the additional overhead octets in each cell. AAL3/4 is rarely used.

AAL5

AAL5 service, like AAL3/4, supports the transfer of data that is less sensitive to delay than AAL1 data. AAL5 is a simpler and more space-efficient protocol than AAL3/4. It relies on higher-level services to handle cell loss and other errors.

AAL5 encapsulates upper-layer SDUs into PDUs. Each PDU has a single trailer, which contains the upper-layer SDU control information, SDU length, and a CRC to guarantee the

ATM Layers

integrity of the entire PDU. AAL5 then segments the PDU into cells, each of which uses the entire 48-octet cell payload to deliver user data.

AAL Sublayers

The AAL for all service classes consists of two sublayers:

- The Segmentation and Reassembly (SAR) sublayer converts data into cells, and cells back to data.
- The Convergence Sublayer (CS) meets the specific service requirements of the next higher layer.

In AAL3/4 and AAL5, the Convergence Sublayer consists of two further sublayers:

- The Service Specific Convergence Sublayer (SSCS) handles details of the higher layer's specific services.
- The Common Part Convergence Sublayer (CPCS) converts upper-level SDUs to AAL PDUs.

Figure C-5 illustrates the protocol model for AAL3/4 and AAL5 sublayers:

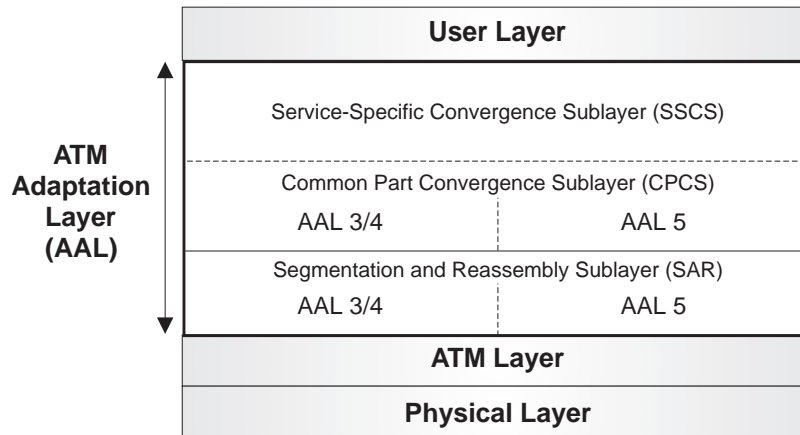

Figure C-5. Protocol Model for AAL3/4 and AAL5

Figure C-6 illustrates how the AAL5 sublayers handle data segmentation:

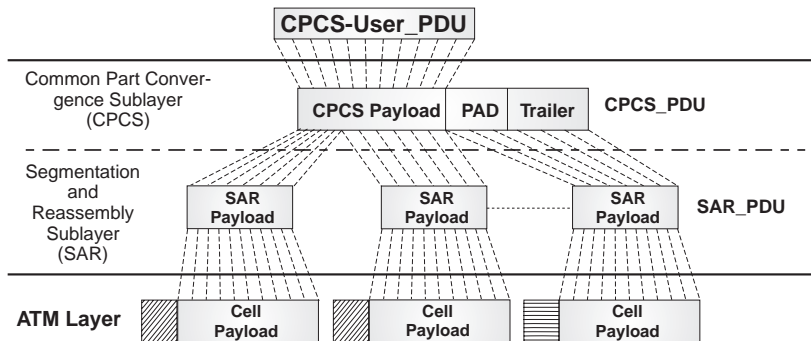

Figure C-6. AAL5 Sublayers

SONET/SDH

SONET (Synchronous Optical Network) is a North American multiplexing standard that defines a signal used in optical fiber networks. For ATM over fiber, OC-3c, with a base rate of 155.520 Mbps, is the most widely-used signal in the US.

SDH (Synchronous Digital Hierarchy) is the European equivalent of SONET. STM-1 (Synchronous Transport Mode, Level 1) is the European equivalent of OC-3c. Like OC-3c, STM-1 has a base rate of 155 Mbps, but STM-1 has slightly different framing information than the OC-3c signal.

Integrated Local Management Interface

Integrated Local Management Interface (ILMI) is the ATM Forum specification for incorporating network management into ATM networks. ILMI is based on the Simple Network Management Protocol (SNMP). The Interface Management Entities (IMEs) on the end station and the switch use ILMI to manage the physical link connecting them.

A subset of ILMI, known as *address registration*, is used when a station is connected to the ATM network. Address registration lets the end station and the switch dynamically build a unique ATM End Station Address (AESA). The AESA consists of two parts, the end station identifier (ESI) and the network prefix, which are concatenated together to define the end station's unique ATM network address.

- The ESI is the ATM adapter's unique 6-byte identifier.
- The network prefix is the 13-byte link address, as determined by the ATM switch.

LAN Emulation

LAN Emulation (LANE) is designed to allow existing network applications and network protocols to run over ATM networks. It supports ATM as a backbone for connecting *legacy* networks such as Ethernet, FDDI, and Token Ring. It supports efficient interaction for both directly-attached ATM end systems (in their own subnet) and legacy end systems attached through Layer 2 bridging devices.

LAN Emulation allows multiple emulated LANs (ELANs) to exist on the same physically interconnected ATM network. For example, using an appropriate ATM network interface card, an ATM end station can communicate with all of the following:

- An Ethernet segment on one ELAN
- A Token Ring segment on a second ELAN
- An FDDI segment on a third ELAN
- A fourth ELAN comprised of ATM nodes only (taking full advantage of high-speed ATM communications)

LAN Emulation Multiple Protocol Support

LAN Emulation supports a wide variety of protocols primarily because the functionality of the LANE interface is defined at the MAC layer. This allows for protocol-independent data transfer between devices attached to the ELAN and to other legacy-attached devices, as shown in Figure C-7:

LAN Emulation

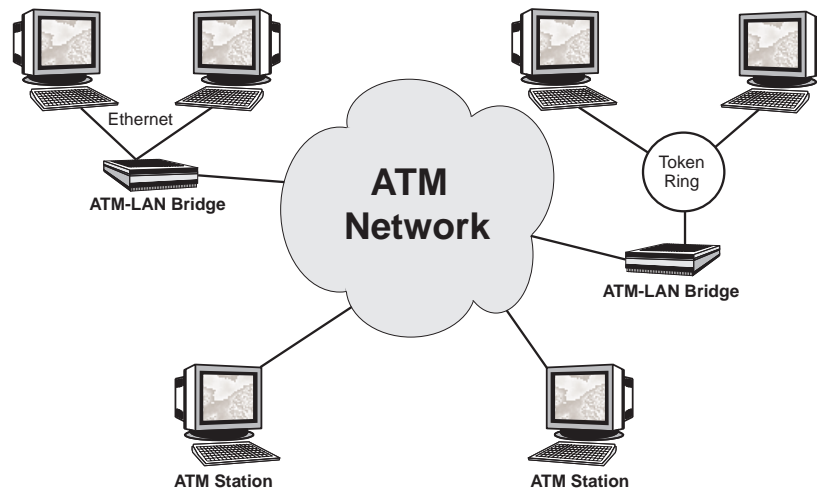

Figure C-7. ATM LAN Emulation

MAC-Dependent Protocol Support

However, LAN Emulation does not support protocols or applications that are dependent on MAC layer protocols, such as SMT/Token Management and CSMA/CD. These MAC-dependent applications are designed to deal with specific media issues such as ring arbitration and collision detection. In addition, because each ATM link carries traffic destined only for the one station attached to that link, a given station cannot receive all of the ELAN's frames like it would on a shared media network.

Therefore, removing the old equipment and installing LAN Emulation-based ATM equipment does not solve existing Ethernet/Token Ring/FDDI bridging problems.

Legacy LAN Protocol Support

LAN Emulation enables legacy LAN applications to operate over ATM while hiding the complexities of ATM point-to-point connections. With LAN Emulation, an ATM switch arranges ATM stations into groups that can implement and receive each other's broadcast/multicast requests. LAN Emulation supports requests in Ethernet and Token Ring frame formats, enabling legacy applications to run without modification over ATM networks. (LANE Emulation also supports FDDI, which uses Ethernet frames.)

LAN Emulation implements this frame format support with true MAC-level bridging. Multiple protocols, such as IP, IPX, and NetBIOS, can communicate across the ATM-LAN bridge. To illustrate how LAN Emulation works, Figure C-8 shows how an ATM host, an ATM-LAN bridge, and a legacy LAN host fit into the same network.

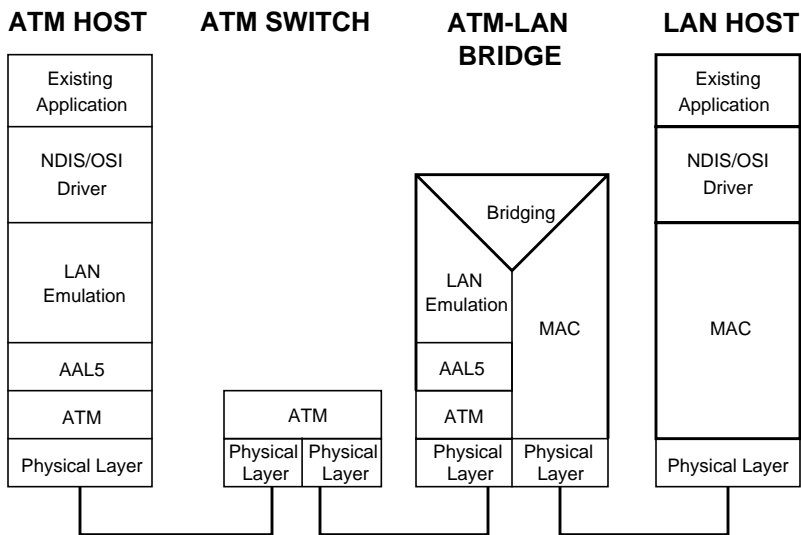

Figure C-8. LAN Emulation Protocol Stack

LAN Emulation

The goal of LAN Emulation (on the ATM side of the bridge) is to convince the upper layer protocols that a MAC layer of a legacy LAN lies in the lower layers, when actually it does not. The only discernible difference is that ATM's emulated LAN interface operates at much higher transmission rates.

All LAN Emulation connections (as defined by the ATM Forum) use the AAL5 ATM Adaptation layer to reassemble and segment the PDUs of legacy LANs into 53-byte ATM cells. The ATM-LAN bridge implements the MAC layer emulation to and from the legacy LAN. As illustrated by the LAN Host diagram in Figure C-8 on page 95, existing software requires no changes to run over ATM networks. ATM switches transport the cells just as they would for any other connection.

LAN Emulation Services

The LAN Emulation Client (LEC) defines the interface between a MAC layer entity of an ATM node and the emulated LAN. The LAN Emulation Service defines how the protocol interoperates with multiple LECs. It provides functions for initialization, address registration and resolution, and data forwarding. The three components that implement these functions are:

- LAN Emulation Configuration Server (LECS)
- LAN Emulation Server (LES)
- Broadcast and Unknown Server (BUS)

Some vendors provide these services in one or more switches, while others provide them in end station or edge devices.

LAN Emulation Configuration Server

The LECS provides a central point of contact for each LEC on the ATM network. It provides each LEC with configuration information, including the address of the LES that serves a specific ELAN. At bootup, LECs initially communicate with the LECS to locate the appropriate LES for their emulated LAN. The connection between the LEC and the LECS can be terminated when this transfer of information is complete.

Network personnel implement and maintain LECS information. Depending on the vendor, the LECS implementation might also provide numerous features such as support for multiple ELANs, ELAN management based on MAC addresses, and other network management features.

LAN Emulation Server

The LES provides LAN Emulation address resolution. This is a critical function because MAC addresses are 6-byte entities and ATM addresses are 20-byte entities. Each LEC notifies the LES of its MAC-ATM address bindings. The LES stores the MAC-ATM relationship so it can resolve queries from other clients for these MAC addresses.

All LECs on an ELAN connect to the same LES. All LECs on the same ELAN must log in with the LES before attempting to communicate with any other LEC in the group. They also must use the same Maximum Transfer Unit (MTU) size. An ELAN's MTU size depends on what type of legacy edge devices (if any) are being supported.

If the network interface card at the ATM node supports multiple LECs, each LEC on the card can be configured to a different ELAN and have a different MTU size than the other

LAN Emulation

LECs. For example, three different LECs on the card might be configured as follows to communicate with nodes on three different ELAN types:

- LEC1 is configured to use a 1.5K MTU size to communicate with nodes on Ethernet subnets.
- LEC2 is configured to use a 4.5K MTU size to communicate with nodes on Token Ring and FDDI subnets.
- LEC3 can use a 9K (or maximum rate) MTU size to communicate with all ATM-only nodes on the ELAN.

If clients require more than one ELAN with the same MTU size, network personnel can configure differentiating characteristics (for example, logical names) in the LECS.

The connection between the LES and each LEC is open as long as the LEC is up and running. The LES maintains information about all LECs currently connected to the server. When a LEC is disconnected or turned off, the LES removes all information about the LEC.

Therefore, ATM networks using LAN Emulation support relocation of end stations with ease. Moving a station is a matter of physically moving the hardware to a new location, connecting it to the same or another ATM switch in the network, and turning on the power. At bootup, each client contacts the LECS; the LECS supplies the ATM address for the appropriate LES; the client joins the LES, and can then start communicating with other clients on that ELAN.

Broadcast and Unknown Server

The Broadcast and Unknown Server (BUS) provides a simplified mechanism to support both broadcasting and bridged network functionality. Most protocols use the network

topology's shared media broadcast capabilities to implement the mechanism for translating network addresses to MAC addresses.

Because ATM is inherently non-shared, additional work must be done to enable every station on an ELAN to receive the broadcast and multicast frames. The BUS is a centralized server for the ELAN that accepts broadcast traffic from all clients in the group and then forwards that traffic to all the clients on a point-to-multipoint connection.

LAN Emulation Protocol

This section describes how the various phases of the LAN protocol accomplish the goal of getting multiple stations to communicate in the ATM network environment. The LAN Emulation protocol phases are:

1. Initialization
2. Configuration
3. Joining
4. Registration and BUS initialization
5. Data movement

Initialization

At power-up or reset, during initialization, a LEC's first action is to establish a connection with an LECS. The protocol defines a multi-step procedure to ensure that the LEC can reach the LECS in a variety of environments.

LAN Emulation

The first mechanism involves getting the LECS address(es) via ILMI. If no addresses are listed, or if none of the addresses work, the LEC uses the *well-known* ATM address (defined by the ATM Forum). An error occurs if this address does not work.

Additionally, as an out-of-band mechanism for obtaining the required configuration, network personnel can enter the address of the appropriate LES directly in the LEC setup.

Configuration

After the LEC establishes a connection to the LECS, the LEC transmits a message to the LECS. The message provides the LEC's ATM address, MAC address, LAN type, and frame size (MTU) request. When the LECS validates the request, it returns configuration information about the appropriate LES, including the LES's ATM address and the LAN type and frame size for the LEC to use for the session.

Joining

When the LEC gets the ATM address of the LES, it attempts to join the ELAN by creating a permanent connection to the LES. When it connects, the LEC transmits a message to the LES providing the configuration information obtained from the LECS and, optionally, a MAC address to register. A separate registration message can be used to register additional MAC addresses. The join process culminates in the LES adding the client as a leaf to its point-to-multipoint tree.

Registration and BUS Initialization

Upon joining the LES, the LEC requests the ATM address for the *all 1's* broadcast MAC address. The LES responds with the ATM address for the Broadcast and Unknown Server.

The LEC then initiates a Multicast Send connection to the BUS and accepts the incoming Multicast Forward multipoint VCC from the BUS.

Data Movement

After BUS connections are established, the LEC can begin forwarding frames. When a data frame needs to be transmitted, the LEC checks an internal table to see if a connection already exists for the destination MAC address. If so, it transmits the frame on that VCC. Otherwise, it queries the LES for the ATM address that corresponds with the MAC address. While waiting for a response, it forwards the frames destined for this MAC address to the BUS.

For a device on the legacy side of a bridge, the bridge learns the device's MAC address when the device starts transmitting. Then future requests to resolve the MAC address result in the bridge responding with its own ATM address.

Connections time out after periods of 20 minutes of inactivity in both directions. MAC entries received from the bridges are also timed out and reverified. This is done to support station movement on the legacy network where the edge devices do not have definitive knowledge of station movement activity.

LAN Applications

The advantage of LAN Emulation is that existing applications and protocols can be adapted to ATM merely by installing new ATM interfaces and drivers. The disadvantage is that these driver interfaces do not utilize any of the benefits of ATM, such as a varying quality of service, full ATM addressing, and other non-LAN protocol applications.

For future software designs, the ATM Forum has developed a Native Service Interface, which defines how new applications can be adapted to ATM networks, multiple vendors, and WinSock 2 support. This development provides an evolutionary solution where existing applications can continue to work as before, while new applications can take full advantage of ATM capabilities. The two interfaces are able to coexist in the same end systems.

Multiprotocol Encapsulation over ATM AAL5

The Internet Engineering Task Force (IETF) defines Multiprotocol Encapsulation over ATM AAL5 in RFC-1483. Multiprotocol Encapsulation over ATM AAL5 provides methods for encapsulating existing network protocol frames so that they can be transported over ATM in AAL5 frames. This encapsulation enables higher-layer protocols to use ATM networks to interconnect and exchange existing frame types.

RFC-1483 defines two encapsulation methods:

- The first method, *LLC encapsulation*, allows different frame types to be multiplexed over the same ATM VC. LLC encapsulation uses IEEE 802.2 Logical Link Control (LLC) headers to differentiate frame types. This is the primary method used in most environments.
- The second method, known as *VC Based Multiplexing* or *Null Encapsulation*, allows one frame type to exist on the VC because no encapsulation is used.

There are two classes of protocol frames:

- Routed protocols

An example of a routed protocol is IP, which is the encapsulation defined in RFC 1577 to carry IP data over ATM networks.

- Bridged protocols

Examples of bridged protocols are Ethernet and FDDI, which many ATM PVC services use to interconnect like legacy networks.

Specific encapsulation rules are spelled out for each class. In general, the LLC header identifies the encapsulated payload.

Classical IP over ATM

Classical IP (CIP) over ATM is designed to allow existing unicast IP network applications to run over ATM networks. The Internet Engineering Task Force (IETF) defines Classical IP in RFC 1577. Classical IP over ATM uses LLC Encapsulation for Routed Protocols, as defined in RFC-1483, for data encapsulation.

Figure C-9 on page 104 illustrates a Classical IP over ATM network configuration. Figure C-10 on page 104 illustrates the Classical IP over ATM protocol stack.

Classical IP over ATM

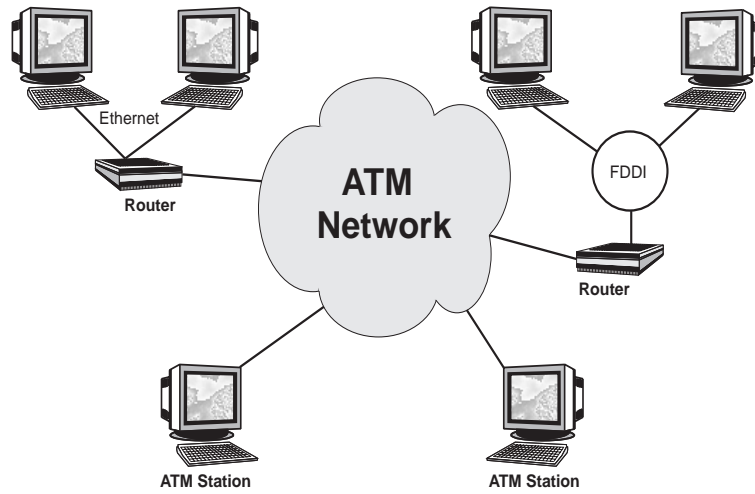

Figure C-9. Classical IP over ATM

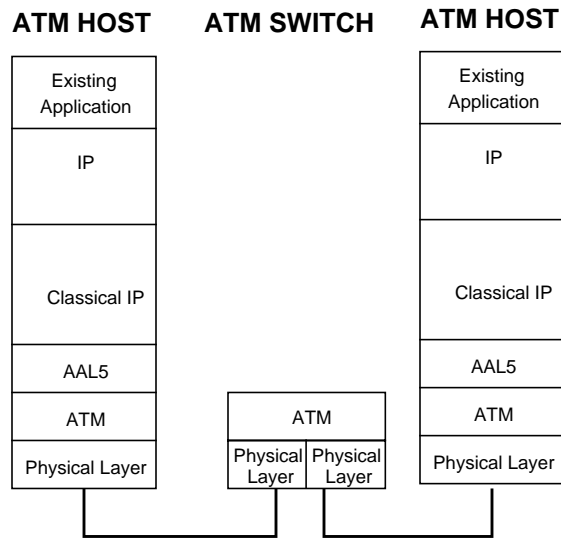

Figure C-10. Classical IP Protocol Stack

Classical IP Client Interface

The CIP Client defines the interface between an IP layer entity of an ATM node and the Logical IP Subnetwork (LIS). The standard supports only the delivery of unicast IP packets over ATM networks. To transfer a unicast IP packet, the CIP client must translate the IP address to an ATM address, create an SVC to that host, and then pass LLC encapsulated IP data over that VC.

The ATM ARP Server provides address resolution service to CIP clients. The ATM Address Resolution Protocol (ATMARP) defines how a CIP client can obtain the ATM address of an IP client it wants to connect to. This is done with ARP on broadcast enabled networks. Because the ARP protocol requires a broadcast medium, IP over ATM networks use an additional protocol, the Inverse ATM Address Resolution Protocol (InATMARP), which is based on the Inverse Address Resolution defined in RFC 1293.

ATM ARP Servers use InATMARP to discover client address information. IP clients connected by PVC use InATMARP to discover address information about the remote end.

Most vendors provide ATM ARP Server services in one or more switches or ATM-attached devices such as routers.

Classical IP ARP Server

The ARP Server provides address resolution functions for clients on a Logical IP Subnet. Each client connects to the server via an SVC as it comes up on the ATM network or when it needs to resolve the address of another IP attached device. When the client connects, the server acquires the client's ATM to IP address mapping by means of InATMARP and builds a

Classical IP over ATM

table of all the IP addresses on the LIS. Then when a client asks for the mapping via ATMARP, it can return the ATM address the client needs to create an SVC to the device.

Data Movement

When the ARP Server connection is established, the CIP client resolves IP to ATM address mappings and directly connects to other CIP Clients. When it needs to transmit a data frame, the client checks an internal table to see if a connection already exists for the destination IP address. If so, it encapsulates that frame with an LLC/SNAP header and transmits the frame on that VCC.

Otherwise, it queries the ARP Server for the ATM address that corresponds to the IP address. The Client then sets up an SVC to that ATM address and transmits the frame. For a device on the legacy (such as Ethernet) side of a router, the router's IP address must be configured as the gateway for the legacy subnet or as the default gateway for all unknown IP addresses not resolved by the ARP Server.

CIP Applications

The advantage of CIP is that existing IP unicast applications can be adapted to ATM merely by installing new ATM interfaces and drivers. They also perform better than other types of applications because of the larger MTU size supported by CIP.

The disadvantage is that the ATM driver interfaces do not utilize any of the benefits of ATM beyond its bandwidth and larger MTU support. The driver interfaces also do not support broadcast or multicast applications under CIP.

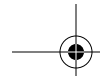

For More Information

For more information about ATM networking, see
<http://www.atmforum.com>



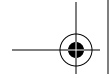

For More Information

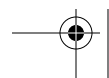
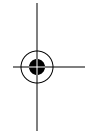

Glossary

The ATM Forum's glossary is at <http://www.atmforum.com> (click on the **Glossary** icon).

The following glossaries may also be helpful:

- Networking Glossary: <http://www.ctcnet.com/tips/glossary.htm>
- Computing Dictionary: <http://wfn-shop.Princeton.EDU/foldoc/>

802.2 IEEE ♦ Standards that govern the LLC within the Data Link layer of the OSI model. LLC frames carry user information between the nodes on a network and define the transmission of a frame between two stations. These standards are common across the various lower level standards within the Data Link and the Physical layers.

802.3 IEEE ♦ Standards that govern the use of the CSMA/CD (Carrier Sense Multiple Access/Collision Detection) network access method used by Ethernet networks.

802.5 IEEE ♦ Standards that govern the use of the token ring indicator and frame priority.

AAL (ATM Adaptation Layer) ♦ Converts packets of data to 53-byte cells for transmission on the network. Several AALs are defined to provide different types of service for ATM connections, and to provide a method of mapping data from a particular class of service into ATM cells in such a way that the data can be remapped into its original format at the other end of an ATM network.

ABR (Available Bit Rate) ♦ One of the two non-guaranteed service types (the other is UBR). With ABR, the network makes no absolute guarantee of cell delivery, but does guarantee a minimum bit rate for user transmission. ABR also makes an effort to keep cell loss as low as possible through a closed feedback loop conveying congestion information back to the source so the source can adjust its rates.

adapter ♦ A device, usually a user interface card, that physically connects an end station to the network medium (for example, twisted pair, coaxial, fiber).

address registration ♦ A subset of ILMI which enables the switch and end station to dynamically construct an end station address.

Glossary

AESA (ATM End Station Address) ♦ The 20-byte address defined by the ATM Forum for identifying end stations on a private ATM network.

ANSI (American National Standards Institute) ♦ An organization which coordinates, develops, and publishes standards used in the United States.

ARP (Address Resolution Protocol) ♦ The Internet protocol used to dynamically translate the Internet address of a network host to its LAN hardware address. This action is limited to LANs that support hardware broadcasts.

ASIC (Application Specific Integrated Chip)

ATM (Asynchronous Transfer Mode) ♦ A switched, connection-oriented technology for LANs and WANs. ATM accommodates a mix of data types, such as audio, video, and data, on a single network. The multiplexed information is organized into cells, and can be transported between network nodes at many different access and transmission speeds. Synonyms: asynchronous transmission, cell relay.

ATM Forum ♦ A communications industry organization made up of hundreds of vendors and users that defines ATM networking protocols.

ATM LAN ♦ Topology that consists of ATM switches and computer interfaces that provide high data rate connectivity for voice, video, and data (IP and multimedia). In addition, ATM interfaces are being integrated into existing LAN hubs and bridge/router platforms. Besides supporting high bandwidth, ATM LANs map to the WAN via central office ATM switches and services being deployed in the telecommunications world.

attenuation ♦ Signal power lost in a transmission medium as the signal travels from sender to receiver.

backbone ♦ A network configuration that connects LANs to form an integrated network.

bandwidth ♦ Capacity for transmitting data through a given circuit. Generally, the greater the bandwidth, the more information can be sent through a circuit during a given amount of time.

best effort ♦ A QoS class where no specific traffic parameters and no attempts are made to guarantee no cell loss or delay variation.

B-ISDN (Broadband ISDN)

bridge ♦ An internetworking device used to connect two or more computer networks at the MAC level, and to forward MAC packets among those networks.

BUS (Broadcast and Unknown Server) ♦ A LAN emulation server for ATM networks which has the ability to receive broadcast requests and forward them to all the attached LECs, thus emulating the broadcast feature of Ethernet and Token Ring LANs.

CAC (Connection Admission Control) ♦ An ATM function which determines whether a VC connection request should be accepted or rejected.

call control ♦ A process that uses signalling procedures to establish VCs. These connections are much like telephone calls. Synonym: call setup.

CAT-3 (Category 3 UTP) ♦ A type of UTP commonly used with ATM interfaces for cell transmission at low speeds (25 Mbps) and at distances up to 100 meters.

CAT-5 (Category 5 UTP) ♦ A type of UTP commonly used with ATM interfaces for higher-speed cell transmission (155 Mbps).

CBR (Constant Bit Rate) ♦ The continuous transmission of data at a fixed and guaranteed rate over a network with a guaranteed cell delay variation.

CCITT (International Telephone and Telegraph Consultative Committee) ♦ See *ITU (International Telecommunication Union)* on page 114.

CDV (Cell Delay Variation) ♦ A QoS parameter that measures the difference between a single cell's transfer delay (CTD) and the expected transfer delay. It gives a measure of how closely cells are spaced in a VC. CDV can be introduced by ATM multiplexers (MUXs) or switches.

cell ♦ Basic ATM transmission unit. A 53-byte packet comprised of a 5-byte header and a 48-byte payload. User traffic is segmented into cells at the source, transmitted through the ATM switched network, and reassembled at the destination.

cell FIFO ♦ Optimized DMA of ATM cells from reassembly engine to system memory requiring minimal CPU intervention.

cell switching ♦ ATM technology that combines the best features of circuit-and packet-switching technology and supports several classifications of AAL service (voice/video, packet/video, data).

circuit switching ♦ A connection-oriented service that uses switching techniques such as time division. It is an ideal mode for continuous, constant bandwidth applications, such as voice and video.

Glossary

CLIP (Classical IP) ♦ A set of IETF-defined protocols for developing IP over ATM networks. The main issues in the transport of IP over ATM that CLIP resolves are packet encapsulation and address resolution.

CLP (Cell Loss Priority) ♦ A 1-bit field in the ATM cell header that corresponds to the loss priority of a cell. Lower-priority (CLP=1) cells can be discarded in congestion situations.

compression ♦ Method of reducing the quantity of data that must be transmitted across a network, primarily to enable the transmission of voice and video. The major compression standards are JPEG for still images, MPEG/MPEG-2 for full-screen motion images, and Px64 and H.261 for video conferencing.

CPC (Cell Personality Card)

CPCS (Common Part Convergence Sublayer) ♦ Part of the AAL convergence sublayer (CS), it must be present in the AAL implementation. Its task is to pass primitives to the other AAL sublayers (SAR, SSCS). It supports the functions of the standardized Common Part AALs: AAL1, AAL3/4, and AAL5.

CRC (Cyclic Redundancy Check) ♦ A bit errors detection technique that employs an algorithm to calculate a value for the information bits in a packet. The receiver, using the same algorithm, recalculates that value and compares it to the value received. If the two values do not agree, the transmitted packet is considered to be in error.

DLE (DMA/Descriptor List Element) ♦ The structure that describes to the PCI bus interface how to move data between the packet buffer and system memory.

DMA (Direct Memory Access) ♦ A fast method of moving data between two subsystems without processor intervention.

DS3 (Digital Standard 3) ♦ This ANSI standard defines the format of asynchronous data sent at the rate of 44.736 Mbps.

E.164 ♦ An ITU-defined 8-byte address format. In ATM it is typically used in public networks and is provided by the telecommunication carriers, while 20-byte NSAP-format addresses are used in private networks.

EFCI (Explicit Forward Congestion Indication) ♦ A 1-bit field in the cell header that contains information about whether congestion at an intermediate node has been experienced. The EFCI bit is set when, for example, a buffer threshold has been exceeded. When recognized by end stations, causes a reduction in the data rate.

ELAN (Emulated LAN) ♦ See *LANE (LAN Emulation)* on page 114.

end station ♦ A machine, intended for running user application programs, that is connected to a network. In an ATM network, the end station is where an ATM connection is terminated or initiated.

ESI (End Station Identifier) ♦ Six-byte unique identifier that the end station concatenates to the network prefix during address registration to generate an ATM end station address (ESI).

fiber optic cable ♦ A transmission medium designed to transmit digital signals in the form of pulses of light.

FIFO (First In First Out) memory ♦ A type of dual-ported memory where the data is read out in the same order in which it was written in.

fragmentation ♦ A process where large frames from one network are broken up into smaller frames that are compatible with the frame size requirements of the network to which they will be forwarded.

frame ♦ Data in a highly-structured format for the purpose of transmission. *Frame*, *packet*, and *PDU* are equivalent in most contexts.

FTP (File Transfer Protocol)

GFC (Generic Flow Control) ♦ A field in the ATM cell header that supports multiplexing functions. The GFC mechanism is intended to support simple flow control in ATM connections.

HDL (High-level Data Link Control) ♦ A framing protocol specified by the ISO that can provide error-free Data Link layer services.

header ♦ Control information attached to the front of a frame or packet. In ATM cells, the header is the bits in a cell allocated for functions required to transfer the cell payload within the network.

HEC (Header Error Control) ♦ A cell header CRC field that guarantees the integrity of the cell header information.

host ♦ Generally, any computer on a network.

host name ♦ A unique name that identifies each host machine on a network.

ICMP (Internet Control Message Protocol) ♦ A Network layer Internet protocol which enables network IP packets to report errors and other relevant information for packet-processing purposes.

IEEE (Institute of Electrical and Electronic Engineers) ♦ An information exchange organization. Among other functions, it coordinates, develops, and publishes network standards for use in the United States, following ANSI rules.

Glossary

IETF (Internet Engineering Task Force) ♦ Organization responsible for all Internet protocols (for example, IP, TCP, FTP).

ILMI (Integrated Local Management Interface) ♦ The ATM Forum standard, ILMI is used to manage the physical and logical interface between two ATM devices.

IME (Interface Management Entity) ♦ The logical management layer implementing ILMI.

IP (Internet Protocol) ♦ A networking protocol for providing a connectionless (datagram) service to the higher transport protocol. It is responsible for discovering and maintaining topology information and for routing packets across homogeneous or heterogeneous networks. Combined with TCP, it is commonly known as the TCP/IP platform.

IPX (Internetwork Packet Exchange Protocol) ♦ A connectionless Network layer protocol similar to IP.

ISDN (Integrated Services Digital Network) ♦ An early, CCITT-adopted protocol reference model intended to provide a ubiquitous, end-to-end, interactive digital service for data, audio, and video. Synonym: narrowband ISDN.

ISO (International Standards Organization) ♦ An international body that creates networking standards, including the OSI model.

ITU (International Telecommunication Union) ♦ The international standards organization for telecommunications, previously known as the CCITT (International Telephone and Telegraph Consultative Committee). For more information, see <http://www.itu.ch>

isochronous ♦ A time-slot protocol that allows delivery of realtime data by dividing a time slot into equal-size mini slots allocated to different channels for synchronous transmission of information.

jitter ♦ See *CDV (Cell Delay Variation)* on page 111.

KB (Kilobytes) ♦ One kilobyte is equivalent to 1024 bytes when referring to memory size, and 1000 bytes when referring to speed.

Kbps (Kilobits per second)

KBps (Kilobytes per second)

LAN (Local Area Network) ♦ A data communications system designed to operate over a limited geographic distance, such as a single building.

LANE (LAN Emulation) ♦ An ATM Forum service specification that allows a connection-oriented ATM network to emulate legacy LAN (for example, Ethernet or Token Ring) services, such as broadcast.

LAP-D (Link Access Procedure-D) ♦ A Data Link layer procedure using D channel communications, typical of ISDN.

LE-ARP (LAN Emulation ARP) ♦ The ARP used in LAN emulation for binding a requested ATM address to the MAC address.

LEC (LAN Emulation Client) ♦ Typically located in an ATM end system (for example, an ATM host), its task is to maintain address resolution tables and forward data traffic. It is uniquely associated with an ATM address.

LES (LAN Emulation Server) ♦ A server which provides support for the LAN emulation address resolution protocol (LE-ARP). The LECs register their own ATM and MAC addresses with the LES. An LES is uniquely identified by an ATM address.

LECS (LAN Emulation Configuration Server) ♦ A server whose main function is to provide configuration information to an LEC (such as the ELAN it belongs to or its LES).

LIS (Logical IP Subnet) ♦ IP subnet, which is fully contained in an ATM network and served by a Classical IP Server.

LLC (Logical Link Control) ♦ The upper half of the Data Link layer in LANs. Performs error control, broadcasting, multiplexing, and flow control functions. See also *MAC (Medium Access Control)* on page 115.

LLC/SNAP (Logical Link Control/SubNetwork Attachment Point)

local ♦ Describes files and devices, such as disk drives, that are attached to, or on, your machine.

MAC (Medium Access Control) ♦ A set of protocols that are the lower part of the Data Link layer and comprise the basis of the IEEE LAN specifications. In general, MAC determines the way devices can transmit in a broadcast network. See also *LLC (Logical Link Control)* on page 115.

Mbps (Megabits per second) ♦ Transmission speed or rate of one million bits per second.

MBps (Megabytes per second) ♦ Transmission speed or rate of one million bytes per second or 8 Mbps.

MIB (Management Information Base) ♦ The specification that defines objects for referencing variables such as integers and strings. In general, it contains information about the network's management and performance (for example, traffic parameters). See also *ILMI (Integrated Local Management Interface)* on page 114.

Glossary

MTU (Maximum Transmission Unit) ♦ The largest packet that can be sent over a given medium.

multicast ♦ A technique that allows copies of a single packet or cell to be passed to a set of destinations.

multimode fiber ♦ A large-core (62.5 micron) optical fiber through which multiple signals can propagate. Length constraint is 2 kilometers.

network ♦ An interconnection of multiple stations or systems that are able to send messages to and receive messages from one another.

Network Prefix ♦ First 13 bytes of an ATM End Station Address. Assigned by the switch during address registration. Used to route SVC signalling calls in the ATM network.

NIC (Network Interface Card) ♦ A component that connects a station to a network (for example, a LAN). Synonym: *adapter*.

NMS (Network Management Station) ♦ The system responsible for managing a network or a portion of a network. The NMS communicates to network management agents (an agent resides in each managed node) using a network management protocol.

NNI (Network-to-Network Interface) ♦ The interface between two pieces of equipment on a public network.

node ♦ A device, such as a station or concentrator, connected to the network media, usually with an adapter.

NRZI (Non-Return to Zero Inverted) ♦ A data transmission technique where a polarity transition from low to high, or high to low, represents a logical 1. The absence of a polarity transition represents a 0.

NSAP (Network Services Access Point) ♦ In the OSI environment it is the SAP between the network and the transport layers. It identifies a Data Terminal Equipment by a unique address.

OAM (Operations and Maintenance) ♦ Set of administrative and supervisory actions regarding network performance monitoring, failure detection, and system protection.

OAM cell ♦ A cell that contains ATM layer management information. It does not form a part of the upper layer information transfer. Generated by hardware or network administrators. Cell header bits distinguish OAM cells from normal data cells.

OC-3c (Optical Carrier level 3, concatenated) ♦ An optical signal defined with a base rate of 155.52 Mbps. The concatenated signal is indivisible, that is, it cannot be multiplexed and demultiplexed.

OSI (Open Systems Interconnection) Model ♦ The 7-layer protocol model defined by the ISO for data communications.

packet ♦ Data in a highly-structured format for the purpose of transmission. *Frame*, *packet*, and *PDU* are equivalent in most contexts.

packet buffer ♦ Memory used on the Interphase NIC to store data for fragmentation and reassembly. Synonym: Side RAM.

packet switching ♦ Statistical, connectionless switching based on information contained in variable-length packets.

payload ♦ Part of the ATM cell, it contains the actual information to be carried, and may also contain overhead. It occupies 48 bytes.

PDU (Protocol Data Unit) ♦ Data in a highly-structured format for the purpose of transmission. *Frame*, *packet*, and *PDU* are equivalent in most contexts.

PHY (Physical Layer) ♦ Layer 1 of the OSI model. Defines and handles the electrical and physical connections between systems. The Physical layer can also encode data in a form that is compatible with the medium (coaxial, twisted pair, fiber, and so on).

PING (Packet Internet Groper) ♦ An Internet protocol facility used to test the reachability of destinations by sending an ICMP echo request, and waiting for a reply.

PMD (PHY Medium Dependent) ♦ A standard that defines the medium and protocols to transfer symbols between PHYs.

point-to-multipoint connection ♦ A unidirectional, one-to-many VC that allows one station to simultaneously send data to the connected end stations.

point-to-point connection ♦ A bidirectional VC between two end points.

primitive ♦ Data and events passed between a layer service user and a layer service provider.

protocol ♦ A set of rules and conventions that govern the exchange of information between communicating parties.

PVC (Permanent/Provisioned Virtual Circuit) ♦ A VC provisioned for indefinite use in an ATM network, established by the network management system (NMS). See also *SVC (Switched Virtual Circuit)* on page 120.

Q.93B ♦ Early draft of the signalling specification now known as Q.2931, on which UNI 3.0 was based.

Glossary

Q.2110 ♦ ITU's *B-ISDN ATM Adaptation Layer- Service Specific Connection Oriented Protocol*, which is the protocol used to reliably transport signalling PDUs over a point-to-point link (such as between an end station and a switch).

Q.2931 ♦ ITU Recommendation derived from both Q.931 and Q.933 to provide SVC specifications and standards.

QoS (Quality of Service) ♦ The set of ATM performance parameters that characterize the traffic over a given VC.

QoS classes ♦ Five service classes defined by the ATM Forum in terms of the QoS parameters.

Q.SAAL (Signalling ATM Adaptation Layer) ♦ Original ITU draft of the specification of signalling's lower level service interface and transport protocol. Q.SAAL is now technically defined as *Q.2110*, but is still used to refer to this protocol layer.

reassemble ♦ The portion of the ATM SAR that reassembles an incoming multiplexed stream of ATM cells into packets.

RFC (Request for Comment) ♦ IETF documents that contain proposed standards and specifications. RFCs can be either approved, or simply archived as historical recommendations.

RFC-1577 ♦ IETF standard for running Layer 3 IP traffic directly over ATM. See also *CLIP (Classical IP)* on page 112.

RJ-45 connector ♦ Standard 8-wire connector for IEEE 802.3 networks and some telephone applications.

SAAL (signalling AAL) ♦ Service-specific parts of the AAL protocol responsible for signalling. Its specifications, being developed by the ITU, were adopted from N-ISDN.

SAP (Service Access Point) ♦ Functional interface between the layers in the OSI model through which lower layers provide services to the higher layers along with PDUs.

SAR (Segmentation and Reassembly) ♦ The lower half of the AAL. The segmentation portion inserts data from packets into cells, adds any necessary header or trailer bits to the data, and passes the 48-octet payload to the ATM layer. Each AAL type has its own SAR format. At the destination, the reassembly portion extracts the cell payload and rebuilds the packet.

SAR-PDU ♦ The 48-octet PDU that the SAR sublayer exchanges with the ATM layer. It is comprised of the SAR-PDU payload and any control information that the SAR sublayer adds.

SBus ♦ Bus designed by Sun Microsystems that supports a data transfer rate of up to 125MB/s. Specification is IEEE 1496 (1993).

SC (Subscriber Connector) ♦ A connector where the transmit and receive fibers are one keyed module plug that latches.

SDH (Synchronous Digital Hierarchy) ♦ A hierarchy that designates signal interfaces for very high-speed digital transmission over optical fiber links. See also *SONET (Synchronous Optical Network)* on page 119.

SDU (Service Data Unit) ♦ User data passed through a SAP between the layers of the OSI or a similar model.

signalling ♦ An ATM connection procedure that dynamically implements explicit routes through switches to establish a communication link with another station on the network.

single-mode fiber ♦ A small-core (9 micron) optical fiber through which only one signal can propagate. Length constraint for the device used in Interphase products is 20 kilometers.

SLIP (Serial Line Internet Protocol) ♦ A protocol for transmitting and receiving IP datagrams via a serial interface.

SNMP (Simple Network Management Protocol) ♦ A high-level, standards-based protocol for network management, usually used in TCP/IP networks. An SNMP manager controls and measures the activities of SNMP agents that are embedded in nodes and network devices on the network. SNMP relies on MIBs embedded in the network resources to monitor and control the network.

SONET (Synchronous Optical Network) ♦ An ANSI-defined standard for high-speed and high-quality digital optical transmission. It has been recognized as the North American standard for SDH.

SSCF (Service Specific Coordination Function) ♦ Part of the SSCS portion of the SAAL. Among other functions, it provides a clear interface for relaying user data and providing independence from the underlying sublayers. See also *SSCOP (Service Specific Connection-Oriented Protocol)* on page 119.

SSCOP (Service Specific Connection-Oriented Protocol) ♦ Part of the SSCS portion of the SAAL. SSCOP is an end-to-end protocol that provides error detection and correction by retransmission and status reporting between the sender and the receiver. It also guarantees delivery integrity. See also *SSCF (Service Specific Coordination Function)* on page 119.

Glossary

SSCS (Service Specific Convergence Sublayer) ♦ One of the two components of the Convergence Sublayer (CS) of the AAL. It supports the specific requirements of upper-layer protocols.

ST (Straight Through) connector ♦ A connector where the transmit and receive fibers have separate twist-on connections.

station ♦ An addressable node on the network capable of transmitting and receiving data.

STM (Synchronous Transfer Mode) ♦ A packet-switching approach where time is divided into time slots assigned to single channels during which users can transmit periodically. Basically, time slots denote allocated (fixed) parts of the total available bandwidth.

STM-1 (Synchronous Transport Module-1) ♦ An ITU-defined SDH physical interface for ATM digital transmission at the rate of 155.52 Mbps.

STM-n (Synchronous Transport Module-n) ♦ An ITU-defined SDH physical interface for ATM digital transmission at n times the basic STM-1 rate. STM-n and SONET STS-3n transmission rates are equivalent.

STS (Synchronous Transport Signal)

subnet address ♦ An extension of the Internet addressing scheme. Using this method, a site can use a single Internet address for multiple physical networks.

SVC (Switched Virtual Circuit) ♦ A software-created dynamic connection between two network nodes. SVCs are created “on demand” and torn down upon completion of the data transfer.

symbol ♦ The smallest signalling element used by the MAC sublayer. The symbol set consists of sixteen data symbols and sixteen nondata symbols. Each symbol corresponds to a specific sequence of code bits (code group) to be transmitted by the PHY.

synchronous transmission ♦ A data transmission scheme where the interval between transmitted characters is fixed so that start and stop bits are not required. As opposed to asynchronous transmissions, synchronous transmissions are guaranteed a specific percentage of bandwidth on the network medium.

TCP/IP (Transmission Control Protocol/Internet Protocol) ♦ A set of communications protocols that define how different types of computers talk to each other. It is the standard architecture for internetworking multiple organizations, and the common link that ties the huge Internet together.

TELNET ♦ A TCP/IP protocol that supports remote terminal operations via a network.

Token Ring ♦ A 4 Mbps or 16 Mbps network that uses a ring topology and a token-passing access method.

UBR (Unspecified Bit Rate) ♦ With UBR, the source specifies no traffic parameters, and therefore the network does not guarantee transmission quality.

UNI (User-Network Interface) ♦ Definition of the interface between an end system and an ATM switch. Defines a set of specifications for signalling. Produced by the ATM Forum.

UNI 3.0 ♦ ATM Forum UNI specification for the physical (PHY) and ATM layers, the ILMI, OAM (traffic control), and PVC support.

UNI 3.1 ♦ A corrected version of UNI 3.0, this specification also includes SSCOP standards.

UNI 4.0 ♦ This UNI specification covers signalling issues in ABR and VP, as well as QoS negotiation.

UTP (Unshielded Twisted Pair) ♦ Type 3 cable with one or more twisted pairs where the wiring is not protected from electromagnetic and radio frequency interferences. There are two main categories of UTP used in ATM: category 3 for 25 Mbps, and category 5 for 155 Mbps. See also *CAT-3 (Category 3 UTP)* on page 111 and *CAT-5 (Category 5 UTP)* on page 111.

VBR (Variable Bit Rate) ♦ The bit rate available to a user for the transfer of user information that requires a guaranteed service for a bounded variable transmission rate.

VBR-RT (Variable Bit Rate—Real Time) ♦ One of the service types for transmitting traffic which is timing- and control-dependent and is characterized by having both average and peak cell rates. VBR-RT is suitable for carrying traffic such as packetized (compressed) video and audio.

VBR-NRT (Variable Bit Rate—Non-Real Time) ♦ One of the service types for transmitting traffic which is not timing-critical and is characterized by having both average and peak cell rates. VBR-NRT is well-suited to long data packet transfers.

VC (Virtual Channel/Connection/Circuit) ♦ A logical transmission path or connection between two network endpoints.

Glossary

VCC (Virtual Circuit Connection)

VCI (VC Identifier) ♦ A 16-bit identifier in an ATM cell header which, when combined with the VPI, identifies the VC to the next ATM device.

VLAN (Virtual LAN) ♦ A networking environment where users on physically independent LANs are interconnected in such a way that it appears they are in the same LAN workgroup.

VP (Virtual Path) ♦ A logical pipe which can contain a group of VCs that connect network devices.

VPI (VP Identifier) ♦ A field in an ATM cell header which, when combined with the VCI, identifies the VC to the next ATM device.

WAN (Wide Area Network) ♦ A network spanning a large geographical area that provides communications among devices on a regional, national, or international basis.

workstation ♦ A networked computer typically reserved for end-user applications.

Index

When using this index, keep in mind that a page number indicates only where referenced material begins. It may extend to the page or pages following the page referenced.

Numerics

1577 dialog.....45

A

AAL service classes88

 AAL1 service89

 AAL2 service89

 AAL3/4 service.....89

 AAL5 service89

AAL sublayers.....90

 Convergence.....90

 Segmentation and Reassembly90

AAL5 segmentation process.....91

AAL5 statistics.....59

adapter

 configuration27

 configuration overview34

 configuration requirements.....30

 diagram.....1

 features1, 2

 inspecting6

 installing.....5

 network connections15

 specifications.....77

 troubleshooting67

Add ELAN Clients dialog.....56

address registration.....37, 92

ANSI compliance.....77

API field64

Application dialog62

application settings for CellView61

ARP server44, 46, 105, 106

ARP Server Enable field46

ARP Server IP Address field.....46

ARP Server Network Prefix and

 ESI/Selector field.....46

ATM

 address.....29

 cell diagram.....85

 LAN Emulation network diagram ..94

 layers.....86

 network topology diagram.....81

 scalability86

 standards compliance77

 switch.....83, 84

 switch requirements3

 technology overview81

ATM Adaptation layer (AAL)88

ATM End Station Address (AESAs).....92

ATM Integrated Driver (ID 1.0).....1, 19

ATM Layer88

ATM Physical layer87

 PMD sublayer87

 TC sublayer87

B

bootup problems71

bridged protocols103

broadcast address.....3

Broadcast and Unknown Server (BUS)98

Broadcast field44

Bus Interface.....77

C

caution

 cvconf file.....25

 handling the adapter.....6

CCITT compliance.....77

cell header83

cell switching	82	IP-over-ATM clients	44
cells	82	LEC	38
CellView		LECS	49
1577 dialog	45	LES	51
adapter configuration	24, 27	overview of tasks	34
Add ELAN Clients dialog	56	PVCs for IP-over-ATM clients	46
Application dialog	62	PVCs for LEC	42
configuration overview	34	requirements	30
Connections dialog	63	UNI signalling	36
controlling application display	61	connecting to the network	15
Debugging dialog	64	Connections dialog	63
debugging messages	73	Convergence Sublayer	90
dialogs	28, 32	Common Part Convergence	90
displaying signalling connections	63	Service Specific Convergence	90
features	27	CSMA/CD protocol	94
Global routines	61	cvconf.file	25
Insert ELAN Client(s) dialog	57	D	
IP-over-ATM setup	44	data transfer specifications	77
LEC dialog	39	Debugging dialog	64
LEC setup	38	debugging messages	64
LECS dialog	50	debugging messages with CellView	73
LECS setup	49	Default ELAN Type field	51
LES dialog	53	Default MTU Sizes field	51
LES setup	51	diagnostics	77
main dialog	32	disk space requirements	3
main dialog selections	32	driver	
producing debugging messages	64	configuration	27
Setup routines	34	configuration options	32
Signalling dialog	36	features	1, 19
signalling setup	36	hostname for IP interface	23, 24
startup	30	number of IP over ATM clients	24
Statistics routines	58	number of LECs	23
verifying installation of	59	removal	25
CellView dialog	32	requirements	3
Classical IP (CIP) applications	106	setup	34
Classical IP Client Interface	105	E	
Classical IP over ATM		ELAN client mappings for LES	55
client setup	44	ELAN Client Mappings Table	55
network configuration	103	ELAN MTU size	41
client mappings	55	ELAN MTU Size field	41, 54
Common Part Convergence Sublayer	90	ELAN Name field	40, 54
configuring drivers	34		

ELAN Type field	40, 54	ID 1.0	1, 19
emulated LAN (ELAN) services ...	49, 51	IEEE compliance	77
Enable Address Registration field	37	ifconfig options	3
Enable Advanced Settings field	62	ILMI	92
Enable CIP over ATM field	46	ILMI field	65
Enable LEC field	40	ILMI Port Change Detection field	37
Enable LECS field	50	INPHatm installation script	22
Enable LES field	54	Insert ELAN Client(s) dialog	57
encapsulation	44, 48, 102	installing the adapter	5
Encapsulation field	44, 48	installing the driver	19
End Pts on a Pt-Mpt field	63	Integrated Local Management Interface	92
end station ATM address	29	Internet Engineering Task Force (IETF)	102
end station identifier (ESI)	29, 92	interrupts	77
end station requirements	3	Inverse ATM Address Resolution Protocol (InATMARP)	105
environment		IP address	3
operating	78	IP address and subnet mask	46
storage	78	IP Address field	46, 48
ESI	92	IP interface formula	23
ESI/Selector value	29	IP over ATM (RFC-1577) clients ...	19, 24
existing drivers	20	IP over ATM protocol stack	104
F		IP to ATM address mappings	106
FCode updates	79	IP-over-ATM client setup	44
features		IP-over-ATM clients	60
adapter	2	L	
CellView	27	L3MTU size field	41
LAN Emulation	19	LAN Emulation (LANE)	93
software driver	1	LAN Emulation Client	59
Ferrite RFI/EMI suppressor	16	description	96
fiber connections	16	setup	38
fixed-length cells	85	LAN Emulation Client (LEC)	19
G		LAN Emulation Configuration Server	19
global settings for CellView	61	description	97
H		setup	49
hardware		LAN Emulation features	19
ATM switch requirements	3	LAN Emulation protocol phases	99
system compatibility	3	LAN Emulation Protocol Stack	95
header, cell	83	LAN Emulation Protocol Support	93
hostname	23	LAN Emulation Server	
I		description	97
iaparam(8) utility	79		

setup.....	51	interface	3, 77
LAN Emulation Server (LES)	19	problems	72
LAN emulation services.....	96	network prefix.....	29, 92
LAN standards compliance	77	Network Prefix and ESI/Selector field.....	46
LANE clients (LECs)	23	Network Prefix field	37
LEC	38, 59	Null encapsulation	44, 48, 102
LEC dialog.....	39	O	
LECS	49	OSI Model	87
LECS dialog	50	output link (VPI/VCI)	84
LED		P	
description	67	permanent ELAN clients	55
diagnostics.....	70	permanent virtual circuits (PVCs)	84
interpreting	67	pkgadd command	21
troubleshooting.....	70	pkginfo command	20
verifying polarity	17	pkgrm command.....	25
legacy LAN protocol	95	PMD sublayer	87
LES	51	power specifications	77
LES client mappings.....	55	protocol frame classes	102
LES dialog	53	protocol model for AAL3/4 and AAL5	
Link LED	17, 67, 70	sublayers	90
LLC encapsulation	102	Pt-to-Mpt field	63
LLC_Snap encapsulation	44, 48	Pt-to-Pt field.....	63
Logical IP Subnetwork (LIS).....	105	PVC Only field.....	40, 46
M		PVC Settings dialog	43, 48
MAC Address field	40, 43	PVC setup	
MAC address of LEC	40	IP-over-ATM clients	46
MAC address of the adapter.....	29	LEC	42
main CellView dialog.....	32	PVC Table	
maximum cable length	78	IP-over-ATM clients	47
mechanical specifications	77	LEC	42
memory specifications.....	77	R	
minimum cable length.....	78	rebooting the machine	24, 26
MTU size	41, 51, 54, 106	Register Nonstandard Prefixes field.....	38
multiple adapters	23	removing a driver.....	25
Multiprotocol Encapsulation	102	requirements	
N		ATM switch	3
net mask	3	configuration.....	30
network		minimum system.....	3
address.....	29	RFC-1577 (IP over ATM) clients ..	19, 24
connecting to.....	15	RFI/EMI suppressor	16
connections.....	15, 78	RJ-45 connectors	16

routed protocols.....	103	setup.....	34
running CellView.....	30	Solaris version required.....	3
S		SONET.....	1, 92
SC connector.....	16	SPARCstation 10	
scalability.....	86	adapter installation.....	11
SDH.....	92	back panel.....	12
Segmentation and Reassembly sublayer .		backplate extension.....	11
90		inserting adapter.....	13
selector value.....	29	protector plate.....	13
Service Specific Convergence Sublayer .		SPARCstation 2	
90		adapter installation.....	7
Set Table Font field.....	62	back panel.....	8
setting up drivers.....	34	inserting adapter.....	9
IP-over-ATM clients.....	44	replacing the cover.....	10
LEC.....	38	standards compliance.....	77
LECS.....	49	starting CellView.....	30
LES.....	51	Stat Refresh Rate field.....	62
PVCs for IP-over-ATM clients.....	46	statistics for drivers.....	58
PVCs for LEC.....	42	Status LED.....	67, 70
UNI signalling.....	36	Strict	
shutdown command.....	7, 11, 24, 26	ELAN Name field.....	54
signalling		MTU Size field.....	54
ATM switch requirements.....	3	Subnet Mask field.....	46
restarting.....	38	suppressor for UTP cable.....	16
setup.....	36	SVC Range field.....	37
standards compliance.....	77	switch, ATM.....	83, 84
signalling connections settings.....	63	switch, signalling requirements.....	3
Signalling dialog.....	36	switched virtual circuits (SVCs).....	84
Signalling field.....	65	system requirements	
signalling statistics.....	59	memory.....	3
SMT/Token Management protocol.....	94	network address.....	3
software driver		operating system.....	3
configuration.....	27	system compatibility.....	3
configuration options.....	32	T	
features.....	1, 19	TC sublayer.....	87
hostname for IP interface.....	23, 24	temporary ELAN clients.....	55
installation.....	19	troubleshooting.....	67
installing.....	19	bootup problems.....	71
number of IP over ATM clients.....	24	LEDs.....	70
number of LECs.....	23	network problems.....	72
removal.....	25		
requirements.....	3		

U

UNI compliance..... 77
UNI Revision field..... 37
UNI signalling requirements 3
UNI signalling setup..... 36
Updating the FCode..... 79
Use 'Well Known Address' field..... 51
UTP connector 16

V

VC Based Multiplexing 102
VCI field 37, 43, 48
virtual circuit connection (VCC)..... 82
virtual circuit diagram 83
virtual circuit identifier (VCI)..... 83
virtual circuits (VCs) 82
virtual path (VP) 83
VPI field..... 37

W

warning
 computer voltages 7
 laser beam exposure 15
 turning off power 10, 14

Product Registration Card

Please take a minute to register your Interphase product. This will enable us to notify you about software updates and product enhancements.

Name _____
Title _____
Company Name _____
Company Address _____
City _____
State _____ Zip _____ Country _____
Province _____
Telephone () _____
Fax () _____
E-mail Address _____

Which product did you purchase? _____
Serial Number _____
Where did you purchase this product (company name)? _____
Date Purchased _____

Number of client nodes at this site: _____

Operating System(s) being used with this product:

- | | | | |
|----------------------------------|-------------------------------------|--------------------------------------|-------------------------------------|
| <input type="checkbox"/> Solaris | <input type="checkbox"/> SunOS | <input type="checkbox"/> AIX | <input type="checkbox"/> NetWare |
| <input type="checkbox"/> HP-UX | <input type="checkbox"/> IRIX | <input type="checkbox"/> Mac OS | <input type="checkbox"/> Windows NT |
| <input type="checkbox"/> PC NFS | <input type="checkbox"/> DEC Ultrix | <input type="checkbox"/> Other _____ | |

Operating System Version: _____

Network Protocol(s) in use:

- | | | | |
|---------------------------------|------------------------------|------------------------------------|--------------------------------------|
| <input type="checkbox"/> TCP/IP | <input type="checkbox"/> IPX | <input type="checkbox"/> AppleTalk | <input type="checkbox"/> Other _____ |
|---------------------------------|------------------------------|------------------------------------|--------------------------------------|

We welcome your comments, ideas, and suggestions. You can fax additional comments to 214/654-5500, or send them to intouch@iphase.com

If you are interested in receiving information on other products from Interphase, please check the appropriate boxes:

- | | | | | |
|------------------------------|-------------------------------|-------------------------------|--|------------------------------------|
| <input type="checkbox"/> ATM | <input type="checkbox"/> FDDI | <input type="checkbox"/> SCSI | <input type="checkbox"/> Fibre Channel | <input type="checkbox"/> 100 BaseT |
|------------------------------|-------------------------------|-------------------------------|--|------------------------------------|

If you are mailing this card from outside the United States, please add postage.

11/96

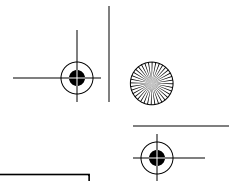
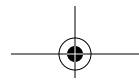
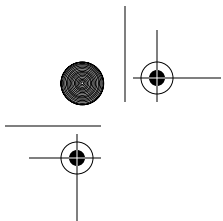

NO POSTAGE
NECESSARY
IF MAILED
IN THE
UNITED STATES

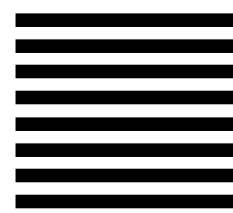

4615-00b Page 130 Thursday, March 12, 1998 11:29 AM

BUSINESS REPLY MAIL
FIRST-CLASS MAIL PERMIT NO. 5784 DALLAS TEXAS

POSTAGE WILL BE PAID BY ADDRESSEE

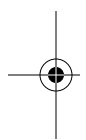

ATTN: WARRANTY DEPARTMENT
INTERPHASE CORPORATION
13800 SENLAC DR
DALLAS TX 75234-9600

