

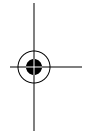

5515/5525/5575 PCI ATM Adapter Users Guide



5515/5525/5575 AIX Quick Install

Print Date: December 12, 1997

With AIX version 4.1.2 or 4.1.4 up and running:

1. Create a temporary directory, and copy the contents of the **AIX** directory from the installation CD-ROM to that directory.
2. Log in as superuser, execute SMIT, and select:
Software Installation and Maintenance
Install and Update Software
Install/Update Selectable Software
Install Additional Device Software
3. Enter the path to the temporary directory and select **4.1.4.0 devices.ip5515x All@@devices.ip5515x**.
4. Return to the System Management dialog and select:
Devices
Install/Configure Devices Added After IPL
5. Initialize the LAN Emulation and IP over ATM clients:
 - a. From the System Management dialog, select:
Devices/Communications
Interphase 5515 ATM Adapter
Interphase 5515 ATM Interface
Add an Interphase 5515 ATM Interface
 - b. Select the clients you want to initialize.
 - c. Return to **Interphase 5515 ATM Adapter**, select **Interphase 5515 ATM Interface Parameters**, and enter your hostname, IP address, and mask for all clients. Verify that Interface Status is set to **up**.
6. Exit SMIT, then see *CellView Utility* in the *Users Guide* to configure the clients and services to your network.
7. When complete, reboot the machine.

The installation of the driver is complete.

5515/5525/5575 IRIX Quick Install

Print Date: December 12, 1997

With IRIX version 6.4 (64-bit kernel only) up and running:

1. Configure the IRIX network interface:
 - a. For each client being initialized, add the IP name and IP address to the `/etc/hosts` file.
 - b. Add the interfaces to the kernel by editing the file:
`/etc/config/netif.options`
 - c. Create the configuration file for each client.
2. Log in as `root`, insert the CD-ROM in the local drive, and enter the command:
`cd /CDROM/IRIX_64bit`
3. Run the installation script to install the driver:
`./inatm [option(s)]`
where `[option(s)]` is the command-line options, if needed, to change the default settings of the driver.
4. If an existing PCI ATM driver is detected on your machine, enter **yes** at the prompt to remove it.
5. You are prompted to confirm the parameters for installing the driver. Enter **yes** at the prompt.
The installation script runs to completion without additional attention.
6. When complete, answer **Yes** to reboot the system.
7. See *CellView Utility* in the *Users Guide* to configure the clients and services to your network.
8. Automate the signalling for boot-time by adding the appropriate startup and shutdown commands to the file:
`/etc/init.d/network`
9. Reboot the machine.

Installation of the driver is complete.

5515/5525/5575 NetWare Server Quick Install

Print Date: December 12, 1997

With NetWare version 3.12, 4.10 or 4.11 up and running, use the NetWare `install` utility and do the following:

1. Select **Driver Options**, select **Configure network drivers**, select **Select an additional driver**, then press **Insert** to install an unlisted driver.
2. Insert the installation CD-ROM and change the path (F3 key) to:
`<drv>:\NetWare`
where `<drv>` is the drive letter of the CD-ROM.
3. Select a driver that matches the speed and type of framing for your network.
4. Select **Select/Modify driver parameters & protocols**.
 - a. If you need to add TCP/IP or AppleTalk, select the protocol you wish to enable. If you are installing an Ethernet driver, you can change the frame type from 802.2 by pressing **F3**.
 - b. Edit the value of Channel to match the increment number in the box titles.
 - c. Select **Save parameters and load driver** and press **Enter** to accept the random network number.
5. Select **No** to exit the configuration, or select **Yes** to configure another client. If Yes, select the same driver for the client and repeat step 4.
6. Add the `load asig` and `load cvconf` commands after the last `BIND` command in the `AUTOEXEC.NCF` file, then restart the server.
7. See *CellView Utility for NetWare Servers* in the *Users Guide* to configure the clients and services to your network.

The installation of the driver is complete.

5515/5525/5575 OS/2 Quick Install

Print Date: December 12, 1997

With OS/2 WARP version 3.0 or later up and running:

1. Start the Multi-Protocol Transport Service, then:
 - Select **Configure**
 - Select **LAN Adapters and Protocols**
 - Select **Configure**The LAPS Configuration dialog appears.
2. Insert the Interphase installation CD-ROM, then:
 - Select **Other adapters**
 - Enter **d:\os2** (for the path to the CD-ROM)The driver and utility files are copied to the hard disk.
3. Initialize the clients:
 - Select the entry for **Lec1** in the Network Adapters list.
 - Select **Add** located under the Network Adapters box.
 - The client appears in the Current Configuration list.Repeat as needed for additional clients Lec2 – Lec4 .
4. Map the network protocols to the clients:
 - Select a client in the Current Configuration list.
 - Select a protocol in the Protocols list.
 - Select **Add** located under the Protocols box.The protocol appears under the client.
Repeat as needed for all clients in the list.
5. When complete, exit the Multi-Protocol Transport Service. You do not need to reboot at his time.
6. See the respective configuration folders for the protocols mapped to the clients and configure each client accordingly.
7. See *CellView Utility* in the *Users Guide* to configure the clients and services to your network.
8. Restart the machine.

The installation of the driver is complete.

5515/5525/5575 SCO Quick Install

Print Date: December 12, 1997

With SCO OpenServer version 5.0 or later up and running:

1. Log in as `root` and switch to single-user mode with the command:

```
init s
```

2. Double click the Software Manager and remove any existing version of an Interphase PCI ATM driver.

3. Insert the installation CD-ROM and mount it with the command:

```
mount -r /dev/cd0 <mount_point>
```

4. From the **SCO** directory on the CD-ROM, copy the media image `VOL.000.000` to a temporary directory on your hard disk, such as `/tmp/iphase`.

5. From the Software menu, select **Install New**.

6. From the Select Media dialog select **Media Images** and enter the full path to the temporary directory.

7. Select **OK**.

The installation may take several minutes to complete and includes several prompts.

8. Answer the prompts about the number of adapters being installed, the number of clients being initialized, the TCP/IP parameters for the clients, and so forth.

9. If multiple adapters are being installed, the prompts in the previous step are repeated for each adapter.

10. See *CellView Utility* in the *Users Guide* to configure the clients and services to your network.

11. Reboot the machine with the command:

```
shutdown -y -i6 -g0
```

The installation of the driver is complete.

5515/5525/5575 Solaris Quick Install

Print Date: December 12, 1997

With Solaris version 2.5 or later and running:

1. Log in as `root`.
2. Run the `df-k` command to verify at least 5MB of free space is available in the `/root` partition and 1 MB is available in the `/usr` partition.
3. Run the `pkginfo` command to check for an existing installation of the driver.

If `INPHatm`, `INPHia`, `INPHipatm`, or `INPHpa` exists, remove it with the command `pkgrm <driver name>` and reboot the machine.

4. Insert the Interphase CD-ROM and run the script:

```
pkgadd -d/cdrom/cdrom0/<path> INPHatm
```

where `<path>` represents `x86_Solaris` for Intel x86 machines or `Sparc_Solaris` for Sun UltraSPARC machines.

The installation of the package may take a few minutes.

5. Answer the prompts about the number of adapters being installed, the number of clients being initialized, the hostname for each client, and so forth.
6. Reboot the machine.
7. See *CellView Utility* in the *Users Guide* to configure the clients and services to your network.
8. When you are finished, reboot the system with the command:

```
shutdown -y -g0 -i6
```

The installation of the driver is complete.

5515/5525/5575 Windows NT 3.51 Quick Install

Print Date: December 12, 1997

With Windows NT version 3.51 up and running:

1. From the Main Group, open the Program Manager, open the Control Panel, double-click the **Network** icon.
2. From the Network Settings dialog, select **Add Adapter**.
3. Select **<Other> Requires disk from manufacturer** from the list box in the Add Network Adapter dialog, then select **Continue**.
4. Insert the instasllation CD-ROM and change the path to the directory that matches your CPU:
 - <drv>:\x86_winNT for Intel x86 machines
 - <drv>:\ppc_winNT for PowerPCswhere <drv> is the drive letter of the CD-ROM.
5. When the Select OEM Option dialog appears, select **OK** to confirm the name of the driver.
The installation may take several minutes.
6. When the Network Settings dialog appears, select **OK**.
7. If TCP/IP is installed on your computer, the TCP/IP Configuration dialog appears. Enter the IP address, net mask, and so forth for all clients.
8. Select **Restart Now** in the Network Settings Change dialog.
9. See *CellView Utility* in the *Users Guide* to configure the clients and services to the network.
10. Restart the machine.

The installation of the driver is complete.

5515/5525/5575 Windows NT 4.0 Quick Install

Print Date: December 12, 1997

With Windows NT version 4.0 up and running:

1. From the Desktop: select **Start, Settings, Control Panel**, then double click the **Network** icon.
2. From the Network dialog, select the **Adapters** tab, select **Add**, then select **Have Disk**.
3. Insert the installation CD-ROM and change the path to the directory that matches your CPU:
 - <drv>:\x86_winNT for Intel x86 machines
 - <drv>:\ppc_winNT for PowerPCswhere <drv> is the drive letter of the CD-ROM.
4. When the Select OEM Option dialog appears, select **OK** to confirm the name of the driver.
The installation may take several minutes.
5. When the Network dialog appears, select **Close**.
6. If TCP/IP is installed on your computer, the Microsoft TCP/IP Properties dialog appears. Enter the IP address, net mask, and so forth for all clients.
7. Select **Restart Now** in the Network Settings Change dialog.
8. See *CellView Utility* in the *Users Guide* to configure the clients and services to your network.
9. Restart the machine.

The installation of the driver is complete.

5515/5525/5575 Windows 95 Quick Install

Print Date: December 12, 1997

1. Install the PCI ATM adapter and turn on the machine.
2. When the New Hardware Found dialog appears:
 - Select **Driver from disk provided by manufacturer.**
 - Select **OK.**
 - Insert the Interphase installation CD-ROM.
 - Enter the path to the CD-ROM: `d:\win95`
 - Select **OK.**

The drivers are copied to your hard disk.

3. When prompted for the Windows 95 install files, insert the Microsoft installation CD-ROM and select **OK.**
4. If you are prompted that setup cannot find the `cellview.cpl` file, insert the Interphase installation CD-ROM and select **OK.**
5. In the System Settings Change dialog, select **Yes** to reboot the computer.
6. Select **Start, Settings, Control Panel**, then double-click the **Network** icon. The Network dialog appears.
7. If a 5525 or 5575 adapter is installed in the machine, replace the 5515 driver as follows:
 - Select **Interphase 5515 PCI ATM Adapter (LEC1).**
 - Select **Remove.**
 - Select **Add.**
 - Highlight **Adapter.**
 - Select **Add.**

The Select Network Adapters dialog appears.

- Select **Interphase 5575/5525 PCI ATM Adapter (LEC1).**
- Select **Have Disk.**

The Install From Disk dialog appears.

- Enter the path to your system directory, typically
`c:\windows\system`
- Select **OK**.

The Network/Configuration dialog reappears with the new driver bound to the adapter.

8. Add or remove the network protocols for LEC1.
9. Configure the remaining protocols for your network.

10. To add additional clients, do the following:

- Select **Add** in the Network/Configuration dialog.
- Highlight **Adapter**.
- Select **Add**.
- Highlight the client you want to initialize.
- Select **Have Disk**.
- Enter the path to your system directory.
- Select **OK**.

The client is initialized and bound to all of the installed protocols.

- Remove the unwanted protocols from the new client.
- Configure the remaining protocols.

Repeat step **10** until you have installed all of the clients you need, up to a maximum of five clients.

11. Select **OK** in the Network/Configuration dialog.
12. You may be prompted to install the `cellview.cpl` file. If this occurs, select **Skip**.
13. You may be prompted for the location of the Microsoft Windows 95 install files. If this occurs, insert the Microsoft installation CD-ROM and select **OK**.
14. When you are prompted to restart the computer, select **No**.
15. See *CellView Utility* in the *Users Guide* to configure the clients to your network.
16. Restart the machine.

5515/5525/5575 UnixWare Quick Install

Print Date: December 12, 1997

With UnixWare version 2.01, 2.1 or 2.11 up and running:

1. Log in as `root` and switch to single-user mode with the command:

```
init s
```

2. Check for an existing installation of the driver:

- a. Enter the command:

```
pkginfo INPHatm
```

- b. If you find an existing driver in the previous step, remove it with the command:

```
pkgrm INPHatm
```

- c. Reboot the machine.

3. Insert the installation CD-ROM and mount it with the command:

```
mount -F cdfs -r /dev/cdrom/device_name mount_point
```

For example,

```
mount -F cdfs -r /dev/cdrom/c0b0t010 /CD-ROM_1
```

4. Run the install script by entering:

```
pkgadd -d /mount_point/UnixWare INPHatm
```

where `mount_point` is the same name you used in the previous step to mount the CD-ROM.

The installation may take a few minutes.

5. Answer the prompts about the number of adapters being installed, the number of clients being initialized, the TCP/IP parameters for each client, and so forth.

6. See *CellView Utility* in the *Users Guide* to configure the clients and services to your network.

7. When complete, reboot the system with the command:

```
shutdown -y -g0 -i6
```

The installation of the driver is complete.

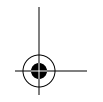
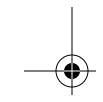
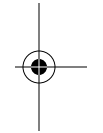
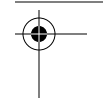
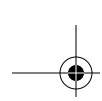
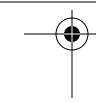



5515/5525/5575 PCI ATM Adapter Users Guide

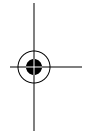

Document No. UG05575-000, REV B

Print Date: December 12, 1997



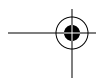
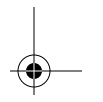
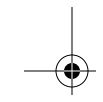
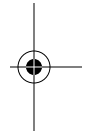
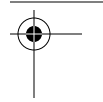
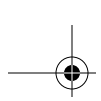
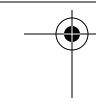

Copyright Notice

© 1997 by Interphase Corporation. All rights reserved.

Printed in the United States of America, 1997.

This manual is licensed by Interphase to the user for internal use only and is protected by copyright. The user is authorized to download and print a copy of this manual if the user has purchased one or more of the Interphase adapters described herein. All copies of this manual shall include the copyright notice contained herein. No part of this manual, whether modified or not, may be incorporated into user's documentation without prior written approval of

Interphase Corporation
13800 Senlac
Dallas, Texas 75234
Phone: (214) 654-5000
Fax: (214) 654-5500

Disclaimer

Information in this manual supersedes any preliminary specifications, preliminary data sheets, and prior versions of this manual. While every effort has been made to ensure the accuracy of this manual, Interphase Corporation assumes no liability resulting from omissions, or from the use of information obtained from this manual. Interphase Corporation reserves the right to revise this manual without obligation to notify any person of such revision. Information available after the printing of this manual will be in one or more Read Me First documents. Each product shipment includes all current Read Me First documents. All current Read Me First documents are also available on our web site.

THIS MANUAL IS PROVIDED "AS IS." INTERPHASE DISCLAIMS ALL WARRANTIES, EXPRESS OR IMPLIED, INCLUDING THOSE OF MERCHANTABILITY AND FITNESS FOR A PARTICULAR PURPOSE OR ARISING FROM A COURSE OF DEALING, USAGE, OR TRADE PRACTICE. IN NO EVENT SHALL INTERPHASE BE LIABLE FOR ANY INDIRECT, SPECIAL, CONSEQUENTIAL, OR INCIDENTAL DAMAGES, INCLUDING, WITHOUT LIMITATION, LOST PROFITS OR LOSS OR DAMAGE TO DATA ARISING OUT OF THE USE OR INABILITY TO USE THIS MANUAL, EVEN IF ADVISED OF THE POSSIBILITY OF SUCH DAMAGES.

Trademark Acknowledgments

Interphase® and Syncard® are registered trademarks and CellView™, (i)chip™, ADSLWatch™, ADSLEye™, SynWatch™, SynEye™, FibreView™, and the Interphase logo are trademarks of Interphase Corporation.

Microsoft®, MS-DOS®, Windows®, and Windows NT® are registered trademarks of Microsoft Corp.

Novell® and NetWare® are registered trademarks of Novell, Inc.

Solaris® and NFS® are registered trademarks and SunOS™ and ONC™ are trademarks of Sun Microsystems, Inc. Sun is a trademark or registered trademark of Sun Microsystems, Inc.

SPARC® is a registered trademark of SPARC International, Inc. SPARCstation™ and UltraSPARC™ are trademarks of SPARC International, Inc., licensed exclusively to Sun Microsystems, Inc.

LattisCell™, EtherCell™, Bay Networks™, and SAHI™ are trademarks of Bay Networks, Inc.

UNIX® is a registered trademark in the United States and other countries, licensed exclusively through X/Open Company Ltd.

IBM® and OS/2® are registered trademarks and AIX™ and PowerPC™ are trademarks of International Business Machines Corporation.

HP-UX® is a registered trademark and Tachyon™ and Precision Bus™ are trademarks of Hewlett-Packard Company.

Intel® and Pentium® are registered trademarks of Intel Corporation.

TI® is a registered trademark of Texas Instruments.

Compu-shield® is a registered trademark of Stewart Connectors Systems, Inc.

Tundra® is a registered trademark and Universe™ is a trademark of Tundra Semiconductor Corporation.

Ethernet® is a registered trademark of Xerox Corporation.

DG/UX® and AViiON® are registered trademarks of Data General Corporation.

Apple® and Power Macintosh® are registered trademarks and Macintosh™, MacOS™, Mac™, AppleTalk™, and Open Transport™ are trademarks of Apple Computer, Inc.

NCR® is a registered trademark of NCR Corporation.

Silicon Graphics® is a registered trademark and SGI™, Indigo™, Indy™, Indigo²™, IRIX™, IRIS™, IRIS Indigo™, Challenge™, and Challenge M™ are trademarks of Silicon Graphics, Inc.

Alpha™ is a trademark of Digital Equipment Corporation.

Gadzoox™ is a trademark of Gadzoox Microsystems, Inc.

Seagate™ and Barracuda™ are trademarks of Seagate Technology, Inc.

ST® is a registered trademark of AT&T.

SCO, The Santa Cruz Operation, SCO OpenServer, and UnixWare are trademarks or registered trademarks of The Santa Cruz Operation, Inc.

SUPERNET™ is a trademark of Advanced Micro Devices, Inc.

Cisco® is a registered trademark and Cisco Systems™ is a trademark of Cisco Systems, Inc.

Adobe® and Acrobat® are registered trademarks of Adobe Systems Incorporated.

CompactPCI® and PICMG® are registered trademarks of the PCI Industrial Computer Manufacturers Group.

Assistance

Product Purchased from Reseller

Contact the reseller or distributor if

- You need ordering, service or any technical assistance.
- You received a damaged, incomplete or incorrect product.

Product Purchased Directly from Interphase Corporation

Contact Interphase Corporation directly for assistance with this, or any other Interphase Corporation product. Please have your purchase order and serial numbers ready.

Customer Service

United States:	Telephone: (214) 654-5555
	Fax: (214) 654-5500
	E-Mail: intouch@iphase.com
United Kingdom:	Telephone: + 44 (0) 1869-321222
	Fax: + 44 (0) 1869-247720
France:	Telephone: + 33 (0) 1 41 15 44 00
	Fax: + 33 (0) 1 41 15 12 13
Asia/Pacific Rim:	Telephone: + 81 35423 6513
	Fax: + 81 3 5423 6511

World Wide Web

<http://www.iphase.com>

Anonymous FTP Server

<ftp.iphase.com>

Safety Precautions

The following general safety precautions must be observed during all phases of operation of this equipment. Failure to comply with these precautions or with specific warnings elsewhere in this manual violates safety standards of design, manufacture, and intended use of the equipment. Interphase Corporation assumes no liability for the user's failure to comply with these requirements. You, as the user of the product, must observe all stated warnings and safety precautions in order to safely operate the equipment in your environment.

Do Not Substitute Parts or Modify Equipment

Because of the danger of introducing additional hazards, do not install substitute parts or perform any unauthorized modification of the equipment. Contact your local Interphase representative for service and repair to ensure that safety features are maintained.

Ground the Instrument

To minimize shock hazard, the equipment chassis and enclosure must be connected to an electrical ground. The power cable must either be plugged into an approved three-contact electrical outlet or used with a three-contact to two-contact adapter, with the grounding wire (green) firmly connected to an electrical ground (safety ground) at the power outlet.

Do Not Operate in an Explosive Atmosphere

Do not operate the equipment in the presence of flammable gases or fumes. Operation of any electrical equipment in such an environment constitutes a definite safety hazard.

Keep away from Live Circuits

Do not install or replace the component with power cable connected. Under certain conditions, dangerous voltages may exist even with the power cable removed. To avoid injuries, always disconnect power and discharge circuits before touching them.

Observe Dangerous Procedure Warnings

Warnings precede potentially dangerous procedures throughout this manual. Instructions contained in the warnings must be followed. You should also employ all other safety precautions which you deem

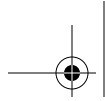

necessary for the operation of the equipment in your operating environment.



WARNING

This equipment generates, uses, and can radiate electromagnetic energy. It may cause or be susceptible to electromagnetic interference (EMI) if not installed and used in a cabinet with adequate EMI protection.



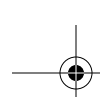

5515/5525/6575 FCC Regulatory Compliance

This equipment has been tested and found to comply with the limits for a Class A digital device, pursuant to part 15 of the FCC Rules. These limits are designed to provide reasonable protection against harmful interference when the equipment is operated in a commercial environment. This equipment generates, uses, and can radiate radio frequency energy and, if not installed and used in accordance with the instruction manual, may cause harmful interference to radio communications. Operation of this equipment in a residential area is likely to cause harmful interference in which case the user will be required to correct the interference at his own expense.

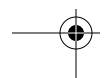

5575 FCC Regulatory Compliance

Tested To Comply With FCC Standards

This device complies with Part 15 of the FCC Rules. Operation is subject to the following two conditions:

- This device may not cause harmful interference.
- This device must accept any interference received, including interference that may cause undesired operation.

Radio Frequency Interference Statement

This equipment has been tested and found to comply with the limits for a Class B digital device, pursuant to Part 15, Subpart B of the FCC Rules. This equipment generates, uses, and can radiate radio frequency energy. If not installed and used in accordance with the instructions, it may cause interference to radio communications.

The limits are designed to provide reasonable protection against such interference in a residential situation. However, there is no guarantee that interference will not occur in a particular installation. If this equipment does cause interference to radio or television reception, which can be determined by turning the equipment on and off, the user is encouraged to try to correct the interference by one or more of the following measures:

- Reorient or relocate the receiving antenna of the affected radio or television.
- Increase the separation between the equipment and the affected receiver.
- Connect the equipment and the affected receiver to power outlets on separate circuits.
- Consult the radio/TV dealer or an experienced radio/TV technician for help.

Modifications

Changes or modifications not expressly approved by Interphase Corporation could void the user's authority to operate the equipment.

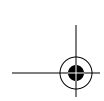

Interphase Fiber Products' Compliance

All Interphase fiber products comply with IEC regulations 825-1 and 825-2 for Class 1 laser devices.

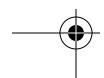
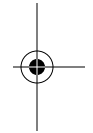

Declaration of Conformity

(according to ISO/IEC Guide 22 and EN 45014)

Manufacturer's Name: Interphase Corporation
**Manufacturer's Address and
Phone Number:** 13800 Senlac
Dallas, Texas 75234
U.S.A.
214/654-5000

declares, that the product:

Product Name: PCI ATM FIBER

Model Number: 5515

conforms to the following Standards:

Safety: EN 60950:1988 + A1, A2

EMC: EN 55022:1988 class A
EN 50082-1 Part 1 1992

Supplementary Information:

This product complies with the requirements of the **Low Voltage Directive 73/23/EEC** and the **EMC directive 89/336/EEC**.

Dallas, June 1, 1995

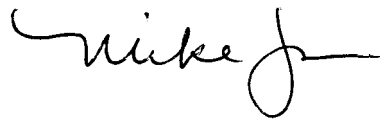

Mike Jobe, Quality Manager

European Contact:

Interphase European Headquarters, Centre d'affaires 10^{ème} Avenue, 855,
avenue Roger Salengro, 92370 Chaville - France
Phone: + 33 (0) 1 41 15 44 00; Fax: + 33 (0) 1 41 15 12 13

Declaration of Conformity

(according to ISO/IEC Guide 22 and EN 45014)

Manufacturer's Name: Interphase Corporation
**Manufacturer's Address and
Phone Number:** 13800 Senlac
Dallas, Texas 75234
U.S.A.
214/654-5000

declares, that the product:

Product Name: PCI ATM UTP

Model Number: 5515

conforms to the following Standards:

Safety: EN 60950:1988 + A1, A2

EMC: EN 55022:1988 class A
EN 50082-1 Part 1 1992

Supplementary Information:

This product complies with the requirements of the **Low Voltage Directive 73/23/EEC** and the **EMC directive 89/336/EEC**.

Dallas, August 7, 1995

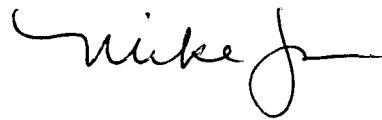

Mike Jobe, Quality Manager

European Contact:

Interphase European Headquarters, Centre d'affaires 10^{ème} Avenue, 855,
avenue Roger Salengro, 92370 Chaville - France
Phone: + 33 (0) 1 41 15 44 00; Fax: + 33 (0) 1 41 15 12 13

Declaration of Conformity

(according to ISO/IEC Guide 22 and EN 45014)

Manufacturer's Name: Interphase Corporation
**Manufacturer's Address and
Phone Number:** 13800 Senlac
Dallas, Texas 75234
U.S.A.
214/654-5000

declares, that the product:

Product Name: PCI ATM UTP

Model Number: 5525Flipper

conforms to the following Standards:

Safety: EN 60950:1988 + A1, A2
IEC 825 -1 & -2 1993

EMC: EN 55022:1988 class A
EN 50082-1 Part 1 1992

Supplementary Information:

This product complies with the requirements of the **Low Voltage Directive 73/23/EEC** and the **EMC directive 89/336/EEC**.

Dallas, June 18, 1996

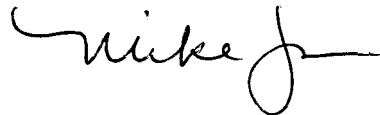

Mike Jobe, Quality Manager

European Contact:

Interphase European Headquarters, Centre d'affaires 10^{ème} Avenue, 855,
avenue Roger Salengro, 92370 Chaville - France
Phone: + 33 (0) 1 41 15 44 00; Fax: + 33 (0) 1 41 15 12 13

Declaration of Conformity

(according to ISO/IEC Guide 22 and EN 45014)

Manufacturer's Name: Interphase Corporation
**Manufacturer's Address and
Phone Number:** 13800 Senlac
Dallas, Texas 75234
U.S.A.
214/654-5000

declares, that the product:

Product Name: PCI ATM UTP

Model Number: 5575

conforms to the following Standards:

Safety: EN 60950:1988 + A1, A2

EMC: EN 55022:1988 class B
EN 50082-1 Part 1 1992

Supplementary Information:

This product complies with the requirements of the **Low Voltage Directive 73/23/EEC** and the **EMC directive 89/336/EEC**.

Dallas, May 5, 1997

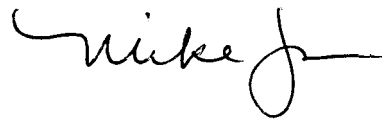

Mike Jobe, Quality Manager

European Contact:

Interphase European Headquarters, Centre d'affaires 10^{ème} Avenue, 855,
avenue Roger Salengro, 92370 Chaville - France
Phone: + 33 (0) 1 41 15 44 00; Fax: + 33 (0) 1 41 15 12 13

Declaration of Conformity

(according to ISO/IEC Guide 22 and EN 45014)

Manufacturer's Name: Interphase Corporation

**Manufacturer's Address and
Phone Number:** 13800 Senlac
Dallas, Texas 75234
U.S.A.
214/654-5000

declares, that the product:

Product Name: PCI ATM Fiber

Model Number: 5575

conforms to the following Standards:

Safety: EN 60950:1988 + A1, A2
IEC 825-1 & -2 1993

EMC: EN 55022:1988 class B
EN 50082-1 Part 1 1992

Supplementary Information:

This product complies with the requirements of the **Low Voltage Directive 73/23/EEC** and the **EMC directive 89/336/EEC**.

Dallas, May 5, 1997

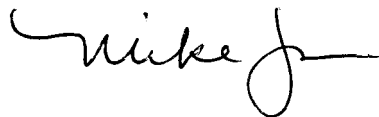

Mike Jobe, Quality Manager

European Contact:

Interphase European Headquarters, Centre d'affaires 10^{ème} Avenue, 855,
avenue Roger Salengro, 92370 Chaville - France
Phone: + 33 (0) 1 41 15 44 00; Fax: + 33 (0) 1 41 15 12 13

Declaration of Conformity

(according to ISO/IEC Guide 22 and EN 45014)

Manufacturer's Name: Interphase Corporation
**Manufacturer's Address and
Phone Number:** 13800 Senlac
Dallas, Texas 75234
U.S.A.
214/654-5000

declares, that the product:

Product Name: CPCI ATM UTP

Model Number: 6575-0-A

conforms to the following Standards:

Safety: EN 60950:1988 + A1, A2

EMC: EN 55022:1988 class A
EN 50082-1 Part 1 1992

Supplementary Information:

This product complies with the requirements of the **Low Voltage Directive 73/23/EEC** and the **EMC directive 89/336/EEC**.

Dallas, December 12, 1997

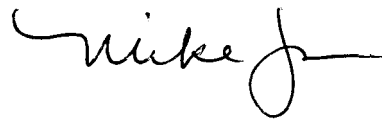

Mike Jobe, Quality Manager

European Contact:

Interphase European Headquarters, Centre d'affaires 10^{ème} Avenue, 855,
avenue Roger Salengro, 92370 Chaville - France
Phone: + 33 (0) 1 41 15 44 00; Fax: + 33 (0) 1 41 15 12 13

Declaration of Conformity

(according to ISO/IEC Guide 22 and EN 45014)

Manufacturer's Name: Interphase Corporation

**Manufacturer's Address and
Phone Number:** 13800 Senlac
Dallas, Texas 75234
U.S.A.
214/654-5000

declares, that the product:

Product Name: CPCI ATM Fiber

Model Number: 6575-0-A

conforms to the following Standards:

Safety: EN 60950:1988 + A1, A2
IEC 825 -1 & -2 1993

EMC: EN 55022:1988 class A
EN 50082-1 Part 1 1992

Supplementary Information:

This product complies with the requirements of the **Low Voltage Directive 73/23/EEC** and the **EMC directive 89/336/EEC**.

Dallas, December 12, 1997

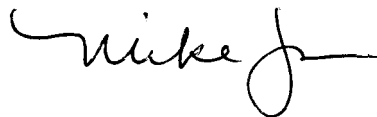

Mike Jobe, Quality Manager

European Contact:

Interphase European Headquarters, Centre d'affaires 10^{ème} Avenue, 855,
avenue Roger Salengro, 92370 Chaville - France
Phone: + 33 (0) 1 41 15 44 00; Fax: + 33 (0) 1 41 15 12 13



5575.b Page 18 Friday, December 12, 1997 6:37 PM

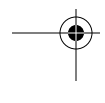
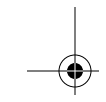
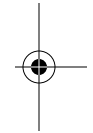
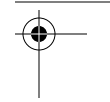
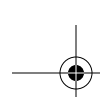
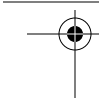

Contents

Preface	vii
Audience	vii
Icon Conventions	vii
Text Conventions	viii
CHAPTER 1 Introduction	
Adapter Overview	1
Product Features	2
Software Drivers	3
Software Documentation Options	4
ATM Switch	5
CHAPTER 2 Hardware Installation	
Overview	7
Inspecting the Adapter	7
Installing the Hardware	8
Connecting the Adapter to the Network	10
CHAPTER 3 Windows NT Driver Installation	
Overview	13
Driver Requirements	14
Installing the Driver for Windows NT 3.51	15
Configuring the Protocols	18
Removing a Driver	20
Installing the Driver for Windows NT 4.0	21
Configuring the Protocols	24
Removing a Driver	26
Configuring the Adapter	28

Contents

CHAPTER 4 CellView Utility

Overview	29
Configuration Requirements	30
ATM Address.....	31
Starting CellView	32
Setup	35
Setting Up UNI Signalling.....	36
Setting Up LAN Emulation Clients.....	39
LEC and LECS/LES ATM Address Settings.....	40
LEC PVC Settings.....	43
Adding or Modifying LEC PVC Table Entries.....	44
Deleting LEC PVC Table Entries	45
Setting Up IP over ATM Client and Server.....	45
IP over ATM Client and ARP Server Settings	47
IP over ATM PVC Settings	48
Adding/Modifying IP over ATM PVC Table Entries... ..	48
Deleting IP over ATM PVC Table Entries	50
Setting Up a LAN Emulation Configuration Server	50
Setting Up a LAN Emulation Server.....	52
LES Settings.....	55
ELAN Client Mappings Settings	56
Adding a Client	57
Inserting Clients	58
Deleting a Client	59
Statistics.....	59
Global Settings	59
Controlling Application Display Settings	60
Displaying Signalling Connections Settings.....	61
Producing Debugging Messages.....	63

CHAPTER 5 NetWare Server Driver Installation

Overview	65
Driver Requirements.....	66
Installing the Driver	67

Contents

Configuring Protocols and Parameters	69
Editing Maximum Packet Size	73
Editing AUTOEXEC.NCF	74
Formatting Commands	75
Automating ATM Startup	78
Editing MTU Size	78
Editing UNI Signalling	80
Changing a LEC to an IP over ATM Client	80
Configuring Multiple Adapters	82
Configuring the Adapter to the Network	83
Verifying the Installation	84
Removing a Driver	85

CHAPTER 6 CellView Utility for NetWare Servers

Overview	87
Configuration Requirements	88
ATM Address	88
Starting CellView	89
Setup	91
Setting Up LAN Emulation Clients	94
LEC and LECS/LES ATM Address Settings	96
LEC PVC Settings	99
Adding or Modifying LEC PVC Table Entries	100
Deleting LEC PVC Table Entries	102
Setting up IP over ATM Client and Server	102
IP over ATM Client and ARP Server Settings	104
IP over ATM PVC Settings	105
Adding/Modifying IP over ATM PVC Table Entries	106
Deleting IP over ATM PVC Table Entries	107
Setting Up a LAN Emulation Configuration Server	108
Setting Up a LAN Emulation Server	110
Statistics	114

Contents

CHAPTER 7 Troubleshooting

Verifying Driver Installation..... 115
LED Diagnostics 117
Bootup Problems..... 119
Network Problems 121

APPENDIX A Specifications

5515/5525/5575 Specifications..... 125
Operating Environment..... 126
Storage Environment 127
Network Connections 127

APPENDIX B UTP Cabling

Straight-through Cable 129
Crossover Cable 129
RJ-45 Connector Pinouts 130

APPENDIX C PCI/PMC Technology Overview

PCI/PMC Technology 131

APPENDIX D ATM Technology Overview

Introduction to ATM..... 133
Virtual Circuits 134
 Virtual Circuit Connections 134
 Permanent Virtual Circuits..... 136
 Switched Virtual Circuits 136
Fixed-Length Cells 137
Scalability..... 138
ATM Layers 138
 Physical Layer 139
 ATM Layer 140
 ATM Adaptation Layer 140

Contents

AAL Service Classes.....	140
AAL1	141
AAL2	141
AAL3/4.....	141
AAL5	141
AAL Sublayers.....	142
SONET/SDH.....	144
Integrated Local Management Interface	144
LAN Emulation	145
LAN Emulation Multiple Protocol Support	145
MAC-Dependent Protocol Support.....	146
Legacy LAN Protocol Support	147
LAN Emulation Services.....	148
LAN Emulation Configuration Server	149
LAN Emulation Server	149
Broadcast and Unknown Server	150
LAN Emulation Protocol.....	151
Initialization	151
Configuration.....	152
Joining	152
Registration and BUS Initialization	152
Data Movement.....	153
LAN Applications	153
Multiprotocol Encapsulation over ATM AAL5	154
Classical IP over ATM.....	155
Classical IP Client Interface.....	157
Classical IP ARP Server	157
Data Movement.....	158
CIP Applications.....	158
For More Information	159
Glossary	161
Index	175

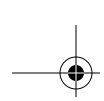

Contents

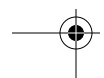

Preface

Audience

This manual assumes that its audience has a general understanding of computing and networking terminology. If you need more information about this terminology (in addition to what this manual provides), see the following web sites:

- ATM Networking:
<http://www.atmforum.com>
- Networking glossary:
<http://www.ctcnet.com/tips/glossary.htm>
- Computing dictionary:
<http://wfn-shop.Princeton.EDU/foldoc/>

Icon Conventions

Icons draw your attention to especially important information:



NOTE

The Note icon indicates important points of interest related to the current subject.

Text Conventions



CAUTION

The Caution icon brings to your attention those items or steps that, if not properly followed, could cause problems in your machine's configuration or operating system.



WARNING

The Warning icon alerts you to steps or procedures that could be hazardous to your health, cause permanent damage to the equipment, or impose unpredictable results on the surrounding environment.

Text Conventions

The following conventions are used in this manual. Computer-generated text is shown in typewriter font. Examples of computer-generated text are: program output (such as the screen display during the software installation procedure), commands, directory names, file names, variables, prompts, and sections of program code.

Computer-generated text example

Commands to be entered by the user are printed in **bold Courier** type. For example:

```
cd /usr/tmp
```

Pressing the return key (↵ **Return**) at the end of the command line entry is assumed, when not explicitly shown. For example:

/bin/su

is the same as:

/bin/su ↵ **Return**

Required user input, when mixed with program output, is printed in **bold Courier** type.



Text Conventions

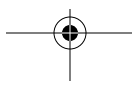

Introduction

1

Adapter Overview

There are three types of PCI ATM adapters from Interphase, the 5515, the 5525, and the 5575. The 5515 and the 5575 support a data rate of 155 Mbps over fiber and copper. The 5525 adapter supports a data rate of 25 Mbps over copper only. The adapters are a single-slot card based on the Interphase (i)chip™SAR (segmentation and reassembly) technology which converts upper layer PDUs (protocol data units) to and from ATM cells for optimal performance.

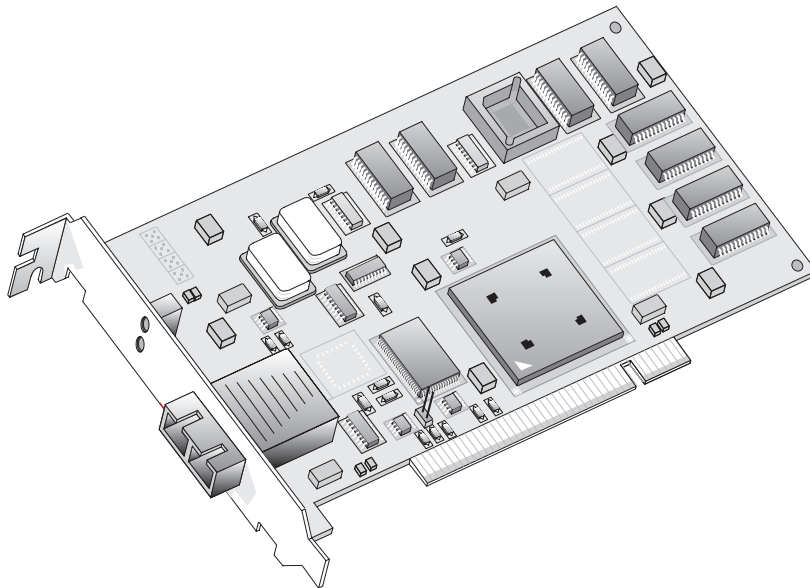

Figure 1-1. 5575 Adapter

Product Features

Packet-to-cell fragmentation and cell-to-packet reassembly take place in the hardware. Transfers to and from the PCI bus are integrated directly with the on-board SAR using Interphase's custom DMA ASIC circuitry. All adapters provide a full range of ATM network communications. The 5575 has the (i)chip™ SAR+ which includes hardware-based ABR in compliance with the ATM Forum Traffic Management 4.0 specification.

Most of the examples and diagrams in this manual refer to the 5575 adapter. This information applies equally to the 5515 and the 5525 except where noted. The network connections available for the boards are shown in the following table:

	Data Rate	Interface	Connections
5515	155 Mbps	SONET OC-3c Fiber SONET OC-3c Fiber SONET UTP	SC Duplex, Single-mode SC Duplex, Multimode RJ-45, UTP Cat 5
5525	25.6 Mbps	AF-PHY-0040.00 UTP	RJ-45, UTP Cat 3, 4, or 5
5575	155 Mbps	SONET OC-3c Fiber SONET UTP	SC Duplex, Multimode RJ-45, UTP Cat 5

Product Features

The PCI ATM adapters support the following features:

- PCI Local Bus Revision 2.1 compliant
- 155 Mbps SONET OC-3c and SDH STM-1 over single-mode or multimode fiber (5515 and 5575)
- 155 Mbps SONET over UTP copper (5515 and 5575)
- 25.6 Mbps AF-PHY-0040.00 over UTP copper (5525)
- 128K standard buffer memory, expandable to 1MB (5515 and 5575)

- AAL5 ATM Adaptation Layer
- UNI 3.0/3.1 standard signalling for SVC connections
- ATM Forum standard LAN Emulation
- IP over ATM (RFC-1577) client and server
- 32-bit, zero wait-state PCI DMA master
- Up to 128-byte burst transfers for the 5575 and up to 64 bytes for the 5515 and the 5525
- Off-board (Cell-FIFO) or on-board packet reassembly
- Hardware-based Segmentation and Reassembly (SAR) functions
- Software status and active line LEDs

Software Drivers

The drivers available for the PCI ATM adapters are as follows:

- AIX™ version 4.1.2 or 4.1.4
- IRIX™ version 6.4 (64-bit kernel only)
- NetWare® version 3.12, 4.10 or 4.11
- OS/2® WARP™ version 3.0 or later
- SCO® OpenServer™ version 5.0 or later
- Solaris™ version 2.5 or later
- UnixWare™ version 2.01, 2.1 or 2.11
- Windows NT® version 3.51 or 4.0

The drivers provide standards-based LAN Emulation and IP over ATM connectivity to an ATM network using Switched Virtual Circuit (SVC) communications. Permanent Virtual Circuits (PVCs) can be set with other endstations based on RFC-1483 standards.

Software Documentation Options

The drivers support the following features:

- Up to eight PCI ATM adapters.
- Up to four LAN Emulation Clients (LECs) per adapter.
- One LAN Emulation Configuration Server (LECS) per adapter.
- Up to eight LAN Emulation Servers (LESSs) per adapter with Broadcast and Unknown frame Server (BUS).

All of which conform to the ATM Forum's LANE Specification 1.0, and can communicate over Ethernet® or Token Ring.

- One IP over ATM client and ARP server per adapter conforming to RFC-1577 standards.

Exceptions to the above features are noted in the installation documentation for each driver.

The installation package also includes two CellView™ ID1.0 utilities for configuring the adapters to the network. The *CellView Utility* on page 29 is a cross-platform, graphical utility used for all operating systems except NetWare servers. The other utility, *CellView Utility for NetWare Servers* on page 87, is specific to NetWare only. Both utilities contain a set of statistical dialogs for displaying pertinent information about the adapters and various system services.

Software Documentation Options

Quick installation cards for all the drivers are located at the front of this users guide. These are useful if you are an experienced user and need only major steps. Expanded procedures for installing the Windows NT and NetWare drivers are located in this manual. Expanded procedures for all other drivers are available in *.pdf format on the installation CD-ROM, as shown in the following table:

OS	Part Number	Directory\FileName
AIX	UG05575-005	AIX\addendum.b.pdf
IRIX	UG05575-010	IRIX_64bit\addendum.b.pdf
OS/2	UG05575-006	OS2\addendum.b.pdf
SCO	UG05575-004	SCO\addendum.b.pdf
Solaris	UG05575-003	either Sparc_Solaris\addendum.b.pdf or x86_Solaris\addendum.b.pdf
UnixWare	UG05575-002	UnixWare\addendum.b.pdf

ATM Switch

Your ATM switch must be capable of supporting the UNI 3.0/3.1 signalling standard for SVCs. Some switch vendors allow mixing of the two standards; some require all ports to be set to either UNI 3.0 or UNI 3.1. Check your switch documentation for the proper settings. The default setting for the Interphase adapters is UNI 3.0.

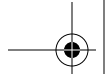

ATM Switch

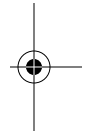

Hardware Installation

2

Overview

These adapters can be installed in any PCI expansion slot on the motherboard. This chapter describes the procedures for physically installing the adapter and include:

- Inspecting the adapter
- Installing the adapter in a host expansion slot
- Connecting the adapter to the network

For adapter specifications, see *Specifications* on page 125.

Inspecting the Adapter

Before installing the adapter in your computer, you need to visually inspect it for damage that might have occurred during shipment from the factory.



CAUTION

The adapter is packed in an antistatic bag to protect it during shipment. Keep the adapter in its protective antistatic bag until you are ready to install it in the host computer. To prevent damage to the adapter due to electrostatic discharge, wear a grounding strap and handle the adapter only by its edges. Do not touch its components or any metal parts other than the faceplate.

Installing the Hardware

1. Open the shipping container and carefully remove its contents.
2. Inspect each item for damage. If you find any omissions or damage, contact your network supplier and the carrier (for example, UPS or Federal Express) that delivered the package.

Installing the Hardware



WARNING

Your computer operates at voltages that can be lethal. Before you remove the computer cover, carefully review the following procedures and observe all cautions and warnings to protect yourself and to prevent damage to the system. Use only insulated or nonconductive tools.

1. Turn off the computer's power switch and unplug the unit from its power source.
2. Remove the computer's cover according to the manufacturer's instructions.
3. Locate a suitable PCI expansion slot and remove the slot's expansion cover.
4. Attach a grounding strap to your wrist or ankle, and carefully remove the adapter from its antistatic bag.

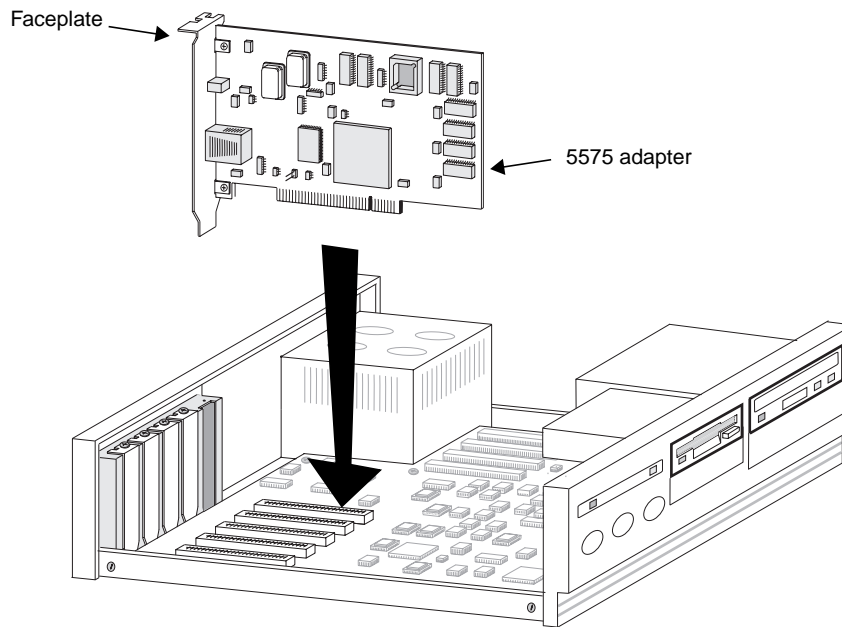

Figure 2-1. Inserting the Adapter

5. Insert the adapter in the PCI slot as shown in Figure 2-1.
6. Press down gently and firmly on the board to seat it in the slot.
7. Secure the adapter in place and replace the computer cover.

Continue the installation with the steps in the next section.

Connecting the Adapter to the Network

With the adapter installed as discussed in the previous section, you are now ready to connect the adapter to the network. The cables and connectors required for each adapter are given in the following table:

Adapter	Connector	Medium	Configuration
5515	SC Duplex	Single-mode fiber	8.25/125 micron
	SC Duplex	Multimode fiber	62.5/125 micron
	RJ-45	Cat 5 copper	UTP
5525	RJ-45	Cat 3, 4 or 5 copper	UTP
5575	SC Duplex	Multimode fiber	62.5/125 micron
	RJ-45	Cat 5 copper	UTP

To connect the adapter to the network, do the following:

1. Attach the appropriate connector to the adapter, as shown in one of the illustrations in Figure 2-2 on page 11.
2. Reconnect the power cable and turn on the machine.

Installation of the hardware for the PCI ATM adapter is complete.

Next, you need to install the appropriate adapter driver. Both quick installation guides and expanded procedures are available. For more information, see *Software Documentation Options* on page 4.

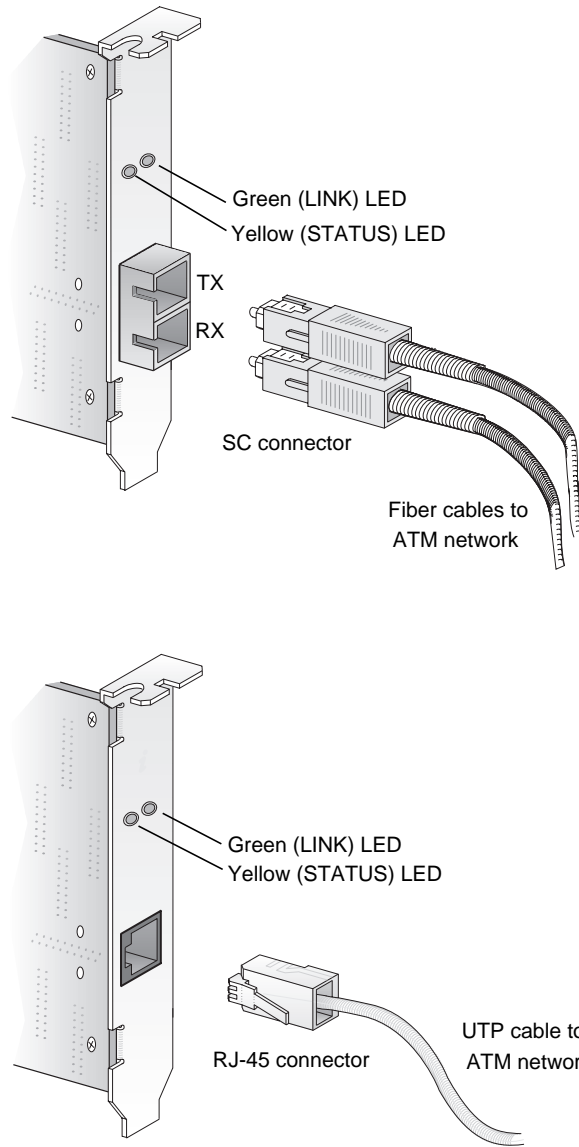
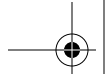
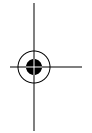

Figure 2-2. Network Connections



Connecting the Adapter to the Network



Windows NT Driver Installation

3

Overview

This chapter contains the procedures for installing the driver for Windows NT version 3.51 or 4.0. The driver is for Switched Virtual Circuits using the User-Network Interface (UNI) 3.0/3.1 signalling specification. The communication links between nodes are set up and torn down dynamically for each transmission of data.

The driver complies with the ATM Forum LAN Emulation specification version 1.0 which provides broadcast/multicast addressing, allowing you to run legacy LAN (Ethernet, Token Ring, and FDDI) applications and protocols over an ATM network. The driver supports multiple Emulated LANs (ELANs) in a single board can belong to four different ELANs simultaneously. An IP over ATM client and server (based on RFC 1577) are available on each adapter, plus all clients can be set to use PVC communications based on RFC 1483.

The Interphase software supports the following:

- Up to eight PCI ATM adapters per system
- Up to four LECs (LAN Emulation Clients) per adapter using both SVC and PVC communications
- One IP over ATM client per adapter using both SVC and PVC communications

Driver Requirements

- Optional Network Services
 - Up to eight LESs (LAN Emulation Servers) on the same adapter as the LECS
 - One LECS (LAN Emulation Configuration Server) on the same adapter as the LESs
 - One IP over ATM server per adapter

During installation, four LECs (Client 0 – Client 3) and one IP over ATM client (Client 4) are initialized per adapter. Client 0 is enabled by default. All remaining clients and LAN services are disabled and are configured to the network with the *CellView Utility* on page 29.

If any *Read Me First* documentation is in your installation kit, review it before installing the driver. It contains any changes and updates to this users guide since the printing date. Also, check for a README file in the `x86_winNT` directory or the `PPC_winNT` directory of the installation CD-ROM. If you are not thoroughly familiar with ATM networking, read the tutorial *ATM Technology Overview* on page 133.

The basic procedures for installing the ATM driver are:

- Verify driver requirements
- Install the driver
- Configure the IP interface

Driver Requirements

The Windows NT workstation must meet the following minimum requirements:

- Intel x86 or PowerPC running Microsoft Windows NT version 3.51 or 4.0
- CD-ROM drive

- 5 MB of free space on the hard disk
- System memory
 - 20 MB minimum
 - 32 MB minimum with multiple clients and LAN services enabled
- TCP/IP interface (if applicable)
 - IP addresses for four LECs and the IP over ATM client
 - Subnet mask for each client

Do one of the following:

- If you are installing the driver for version 4.0, skip to *Installing the Driver for Windows NT 4.0* on page 21.
- Otherwise, begin the installation with the procedures in the next section.

Installing the Driver for Windows NT 3.51



CAUTION

If an earlier version of an Interphase PCI ATM driver is installed on the endstation, you must remove it before proceeding with the new driver (see *Removing a Driver* on page 20).

To install the driver for Windows NT version 3.51, do the following:

1. Boot your system under Windows NT.
2. Log in to your Windows NT administrator account.

Installing the Driver for Windows NT 3.51

3. From the Main Group, open the Program Manager, open the Control Panel, and double-click the **Network** icon.
4. Insert the installation CD-ROM.
5. In the Network Settings dialog, select **Add Adapter**.
6. In the Add Network Adapter dialog, select **<Other>** **Requires disk from manufacturer** then select **Continue**.
7. Run the installation script as follows:
 - a. Change the path to the directory that matches your CPU:
 - <drv>:\x86_WinNT for Intel x86 machines
 - <drv>:\ppc_WinNT for PowerPCswhere <drv> is the drive letter of the CD-ROM.
 - b. When the Select OEM Option dialog appears, select **OK** to confirm the name of the driver.

If you are installing multiple adapters and repeating the installation steps, a message appears advising a network card of this type is already installed. Select **OK** to continue.

The installation may take several minutes. When copying is complete, the dialog in Figure 3-1 on page 17 appears.

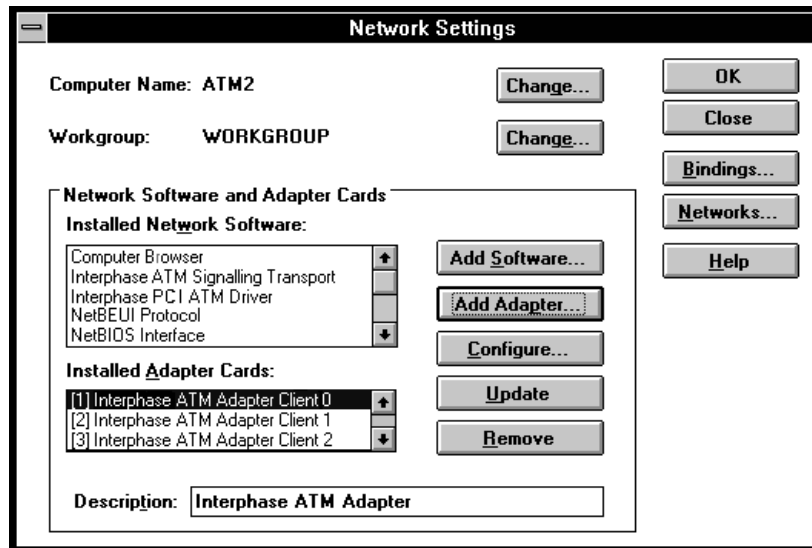

Figure 3-1. Completed Network Settings

Five clients appear in the Installed Adapter Cards list. Client 0 through Client 3 are the LECs and Client 4 is the IP over ATM client for the adapter. Each client is mapped to the adapter with a unique instance number (enclosed in brackets “[]”).

8. To install the driver for additional adapters, repeat steps 5 – 7 until a driver is loaded for every PCI ATM adapter.
9. Select **OK** in the Network Settings dialog.

Continue the installation with the procedures in the next section.

Configuring the Protocols

When you exit the Network Settings dialog as directed in the previous section and TCP/IP is installed on your computer, the TCP/IP Configuration dialog appears.

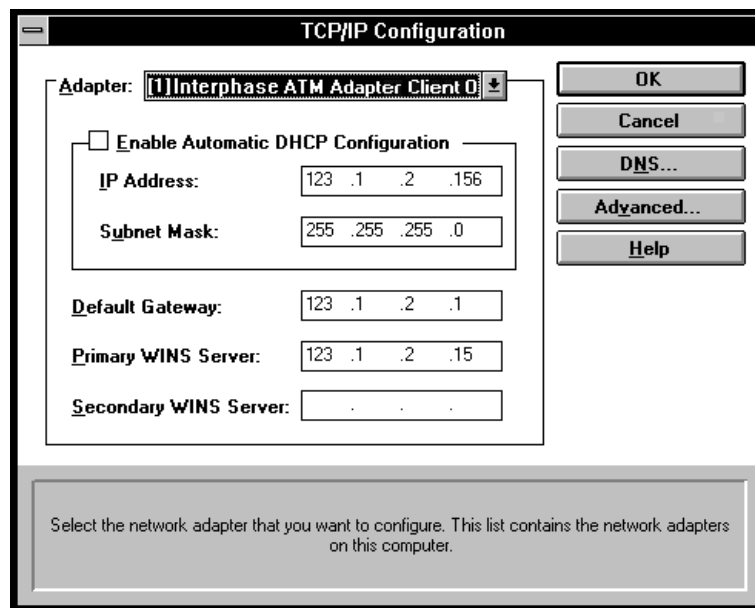

Figure 3-2. TCP/IP Configuration

You must enter an IP address and subnet mask for all clients before exiting this dialog. You can enter dummy numbers for those clients which will not be enabled.



NOTE

The IP addresses shown in Figure 3-2 are examples only. Use the IP addresses for your network.

To edit the TCP/IP Configuration dialog, do the following:

1. Select a client to configure from the Adapter list box.
You can configure the clients in any order; however, it is recommended you work with Client 0 first.
2. Enter the IP Address.
This is the Internet address for the host client. The format is dotted decimal notation in the form xxx.xxx.xxx.xxx, where xxx ranges from 0 to 254.
3. Enter the Subnet Mask.
This mask is used to partition the IP address into subnets at the local company level.
4. Enter the Default Gateway.
This is normally in the form of an IP address identifying your network's leg from a router or other network device.
5. Enter the IP address of the Primary WINS Server.
This is the address of the primary name server used for looking up the host names of local and connected networks.
6. Enter the IP address of the Secondary WINS Server.
The secondary server (if available) is a backup to the primary name server.
7. When all the clients are configured, select **OK**.
8. In the Network Settings Change dialog, select **Restart Now**.

To continue the installation, see *Configuring the Adapter* on page 28.

Removing a Driver

To remove a driver from Windows NT version 3.51, do the following:

1. From the Main Group, open the Program Manager, open the Control Panel, and double-click the **Network** icon.
2. In the Network Settings dialog, select **Interphase ATM Adapter Client 0** in the Installed Adapter Cards list box.

The NT operating system does not allow you to remove any of the drivers individually. You must select Client 0.

3. Select **Remove**.

You are prompted to confirm removal of the adapter.

4. Select **Yes** to remove all the clients and associated drivers.
5. Select **OK** in the Network Settings dialog.
6. Select **Restart Now** in the reboot prompt.
7. Exit Windows NT and reboot the computer.

The driver is now removed from the computer.

Installing the Driver for Windows NT 4.0



CAUTION

If an earlier version of a driver is installed on the endstation, you must remove it before proceeding with the new driver. See *Removing a Driver* on page 26 for instructions.

To install the driver for Windows NT version 4.0, do the following:

1. Boot your system under Windows NT.
2. Log in to your Windows NT administrator account.
3. Insert the installation CD-ROM.
4. From the Desktop:
 - Select **Start**.
 - Select **Settings**.
 - Select **Control Panel**.
 - Double-click the **Network** icon.

The Network dialog appears, as shown in Figure 3-3 on page 22:

Installing the Driver for Windows NT 4.0



Figure 3-3. Network Dialog before Installation

5. In the Network dialog, select the **Adapters** tab.
6. Select **Add**, then select **Have Disk**.
The Insert Disk dialog appears.
7. Run the installation script as follows:
 - a. Change the path to the directory that matches your CPU:
 - <drv>:\x86_winNT for Intel x86 machines
 - <drv>:\ppc_winNT for PowerPCswhere <drv> is the drive letter of the CD-ROM.
 - b. Select **OK**.
The Select OEM Option dialog appears, prompting you to confirm the name of the driver.

c. Select **OK**.

If you are installing multiple adapters and repeating the installation steps, a message appears advising a network card of this type is already installed. Select **OK** to continue loading the driver.

The installation may take several minutes. When copying is complete, the Network dialog reappears.



Figure 3-4. Network Dialog after Installation

Five clients, Client 0 through Client 4, appear in the Network Adapters list. Client 0 through Client 3 are the LECs and Client 4 is the IP over ATM client for the adapter. Each client is mapped to the adapter with a unique instance number (enclosed in brackets “[]”).

Installing the Driver for Windows NT 4.0

8. To install the driver for additional adapters, repeat steps 6 and 7 until a driver is loaded for every PCI ATM adapter.

9. When complete, select **Close** in the Network dialog.

Continue the installation with the procedures in the next section.

Configuring the Protocols

When exiting the Network dialog as directed in the previous section and TCP/IP is installed on your computer, the Microsoft TCP/IP Properties dialog appears.



Figure 3-5. TCP/IP Settings

You must enter an IP address and subnet mask for all clients before exiting the dialog. If needed, you can enter dummy numbers for those clients which will not be enabled.



NOTE

The IP addresses shown in Figure 3-5 on page 24 are sample entries only. Use the IP addresses for your network when editing the TCP/IP parameters.

To edit the Microsoft TCP/IP Properties dialog, do the following:

1. Select a client to configure in the Adapter list box.
You can configure the clients in any order; however, it is recommended you work with Client 0 first.
2. Enter the IP Address.
This is the Internet address for the host client. The format is dotted decimal notation in the form *xxx.xxx.xxx.xxx*, where *xxx* ranges from 0 to 254.
3. Enter the Subnet Mask.
This mask is used to partition the IP address into subnets at the local company level.
4. Enter the Default Gateway.
This is normally in the form of an IP address identifying your network's leg from a router or other network device.
5. Repeat steps 1 – 4 until all clients are configured.

Installing the Driver for Windows NT 4.0

6. Enter the remainder of information in the Microsoft TCP/IP Properties dialog as required for your network.
7. When complete, select **OK**.
The Network Settings Change dialog appears.
8. Select **Yes** to restart the computer.

To continue the installation, see *Configuring the Adapter* on page 28.

Removing a Driver

To remove a driver from Windows NT version 4.0, do the following:

1. From the Desktop:
 - Select **Start**
 - Select **Settings**
 - Select **Control Panel**
 - Double-click the **Network** icon

The Network dialog appears, as shown in Figure 3-6 on page 27.



Figure 3-6. Network Dialog before Installation

2. In the Network dialog, select the **Adapters** tab.
3. Highlight a client and select **Remove**.
A prompt appears for you to confirm removal of the driver.
4. Select **Yes**.
5. Repeat steps 3 and 4 until all clients are removed.
6. Select **Close** in the Network dialog.
The Network Settings Change dialog appears.
7. Select **Yes** to restart the computer.

The driver is now removed from the computer.

Configuring the Adapter

With the driver installed and the machine restarted as directed in previous sections, do the following to complete the installation.

1. Use the Interphase *CellView Utility* on page 29 to enable and configure the clients.
2. When complete, reboot the machine.
3. If you want to verify the driver is installed and operational, see *Verifying Driver Installation* on page 115.

The installation and configuration of the driver for Windows NT is complete.

CellView Utility

4

Overview

CellView ID1.0 is a cross-platform, GUI utility that enables you to configure clients and services for adapters across a wide range of operating systems. This chapter provides information about using CellView to configure the drivers on all operating systems which are compatible with CellView.

CellView enables you to:

- Configure signalling parameters
- Enable, disable, and configure up to four LAN Emulation Clients (LECs) and one IP over ATM client per adapter
- Set Permanent Virtual Connection (PVC) communications with other endstations
- Enable, disable, and configure up to eight LAN Emulation Servers (LESs) and one IP over ATM ARP server per adapter
- Enable, disable, and configure one LAN Emulation Configuration Server (LECS) per adapter
- Display operating statistics for:
 - SONET, signalling, and cell-level activity
 - ATM Adaptation Layer 5 (AAL5) activity
 - LEC membership and activity
 - IP over ATM activity
 - LECS and LES activity
- Set parameters for displaying and updating CellView dialogs

Configuration Requirements

The example CellView dialogs shown in this chapter may vary slightly from the dialogs on your screen. However, the functions are the same. For example, you might use a button to enable a setting where the example shows a check box.

The degree of configuration needed for the adapter(s) depends largely on whether the services are already installed on the network. For example, if the LECS, LESs, and ARP server are running elsewhere on the network, you need to enable and configure only the local clients.

Under Windows NT, at least one client must be enabled and configured on each adapter.

In Windows 95/NT systems, you must exit CellView and restart the machine to make these changes take effect. In UNIX-based systems, all changes except signalling are dynamic when you exit the Setup routines. You can restart signalling from the command line to make signalling changes take effect.

Configuration Requirements

Before you begin the configuration procedures described in this chapter, the following requirements must be met:

- At least one adapter is installed in the endstation.
- The driver for your operating system is installed.
- The machine has been rebooted after the driver installation.

If any of these tasks are not complete, please complete them now. Refer to the appropriate chapter(s) or addendum(s) for instructions.

ATM Address

During configuration, you will need to be familiar with the endstation's unique ATM address, as shown in the following figure.

The screenshot shows a configuration window with three input fields. The first field is labeled 'ATM Address:' and contains the value '47:00:00:00:00:dd:01:00:00:27:2a:84:00:00:00:77:86:da:61-00'. The second field is labeled 'Network Prefix:' and contains the value '47:00:00:00:00:dd:01:00:00:27:2a:84:00'. The third field is labeled 'ESI/Selector:' and contains the value '00:00:77:86:da:61-00'.

Figure 4-1. ATM Address

The Network Prefix and ESI/Selector fields show the separate ATM address components.

The network prefix is the 13-byte link address of the adapter, as set by the ATM switch.

The ESI/Selector consists of a unique endstation identifier (ESI) and a pointer (selector) with the following values:

- The ESI value is the 6-byte MAC address of the adapter (00:00:77:86:da:61 in the example).
- The Selector value is a 1-byte pointer to clients and services located in the endstation (00 in the example).

The Selector value for the endstation is always 00. The Selector values for the clients and services located in the endstation are as follows:

Item Number	Range of Selector Values
LEC1 – LEC4	0x00–0x03
LES1 – LES8	0x20–0x27
BUS1 – BUS8	0x40–0x47

Starting CellView

Starting CellView

The startup procedure for CellView depends on the operating system you are running. The following table describes the startup procedure for each operating system:

Operating System	CellView Startup Procedure
AIX	Enter the command: <code>cellview</code>
HP-UX	Enter the command: <code>cellview</code>
IRIX	Add to your path: <code>/usr/sbin/</code> Enter the command: <code>cellview</code>
OS/2	Enter the command: <code>C:\IBMCOM\CELLVIEW</code>
SCO	Add to your path: <code>/etc/atm/bin</code> Enter the command: <code>cellview</code>
Solaris	Enter the command: <code>cellview</code>
UnixWare	Enter the command: <code>cellview</code>
Windows 95	Select Start . Select Programs . Select Control Panel . Double-click the CellView icon.
Windows NT 3.51	Go to the Main Group. Open the Program Manager . Open the Control Panel . Double-click the CellView icon.
Windows NT 4.0	Select Start . Select Settings . Select Control Panel . Double-click the CellView icon.

When you start CellView, the main dialog appears:

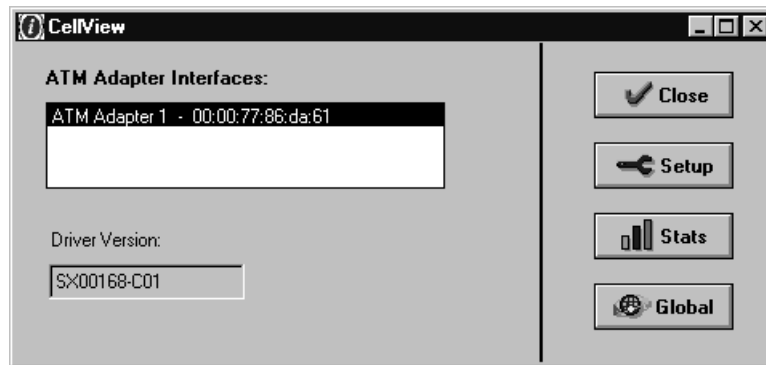

Figure 4-2. Main CellView Dialog



NOTE

For Windows NT, when configuring PCI ATM adapters, the main dialog contains an additional selection box for changing the PCI Interrupt value.

The main CellView dialog lists the adapter(s) installed in your computer and provides navigation buttons. All subsequent dialogs are *child* dialogs. The contents of each Setup and Statistics dialog apply to the adapter that is highlighted in the ATM Adapter Interfaces box.

Starting CellView

The main CellView dialog provides the following selections:

Select...	To do this...
Interrupt (Windows NT only)	Set the PCI interrupt value for the adapter highlighted in the ATM Adapter Interfaces box. We recommend the default AutoDetect setting. If the driver fails to recognize the adapter with AutoDetect set, you might need to set a specific interrupt level.
Close	Exit CellView.
Setup	To configure: <ul style="list-style-type: none"> • Signalling • LECs (4 maximum per adapter) • LESs (8 maximum on same adapter as LECS) • LECS (on same adapter as the LESs) • IP over ATM (RFC 1577) client and ARP server
Stats	To display the status of: <ul style="list-style-type: none"> • Signalling • AAL5 • LECs • LESs • LECS • IP over ATM (RFC 1577) client and ARP server
Global	To configure: <ul style="list-style-type: none"> • Applications (parameters for Setup and Stats dialogs) • Connection limits for endstations (display only) • Debugging (enable tracking of API, Signalling, ILMI)

The setting **Enable Advanced Settings**, which is located in the Application dialog of Global settings, controls whether the LECS and LES tabs appear for editing and viewing in the Setup and Stats routines. If Enable Advanced Settings is set to **OFF** (the default), the tabs do not appear.

Setup

Use CellView Setup dialogs to configure your adapter(s) for the ATM network. You can configure up to four LECs and one IP over ATM client per adapter. The number of clients per adapter is specified during driver installation. You can also configure one LECS and up to eight LESs per adapter for the ATM network.

No particular order is required for configuring clients and services. However, **if you will be enabling the LECS and the LESs**, configure these first before configuring the clients.

Before starting configuration, make sure the preliminary requirements are met, as described in *Configuration Requirements* on page 30. Then start CellView, as described in *Starting CellView* on page 32.

After starting CellView, configure clients and servers for each adapter in the endstation as described in the following overview of Setup tasks:

1. On the main CellView dialog, highlight the adapter you are configuring, and select **Setup** to make dialogs available for setting up signalling, clients, and servers.
2. On the Signalling dialog, check that all signalling parameters conform to the capabilities of your ATM switch, and change settings, if needed.
3. **If the LECS and the LES(s) will be on this machine**, use the LECS and LES dialogs to configure these servers. (You might need to check settings in the Global Application dialog to make these dialogs available.)
4. On the LEC dialog(s), configure the LECs specified for the adapter during driver installation.

Setup

5. On the 1577 dialog, configure the IP over ATM client and ARP server, if specified for the adapter during driver installation.

To make configuration changes take effect in Windows 95/NT systems, exit CellView and restart the machine. In UNIX-based systems, you do not need to reboot the machine for these changes to take effect. All changes to Setup dialogs, except UNI Signalling, are dynamic when you exit Setup. You can restart Signalling without rebooting the machine, as described on page 39.

The following table identifies where to find information about CellView Setup tasks:

For information about...	See page...
Setting Up UNI Signalling	36
Setting Up LAN Emulation Clients	39
Setting Up IP over ATM Client and Server	45
Setting Up a LAN Emulation Configuration Server	50
Setting Up a LAN Emulation Server	52

Setting Up UNI Signalling

The ATM adapter drivers are designed to operate with the UNI 3.0/3.1 signalling specification. All connections between two endstations are set up and torn down dynamically using SVC communications.

To set up UNI signalling parameters:

1. On the main CellView dialog, highlight the adapter you want to configure. Then select **Setup** to display the Signalling dialog:

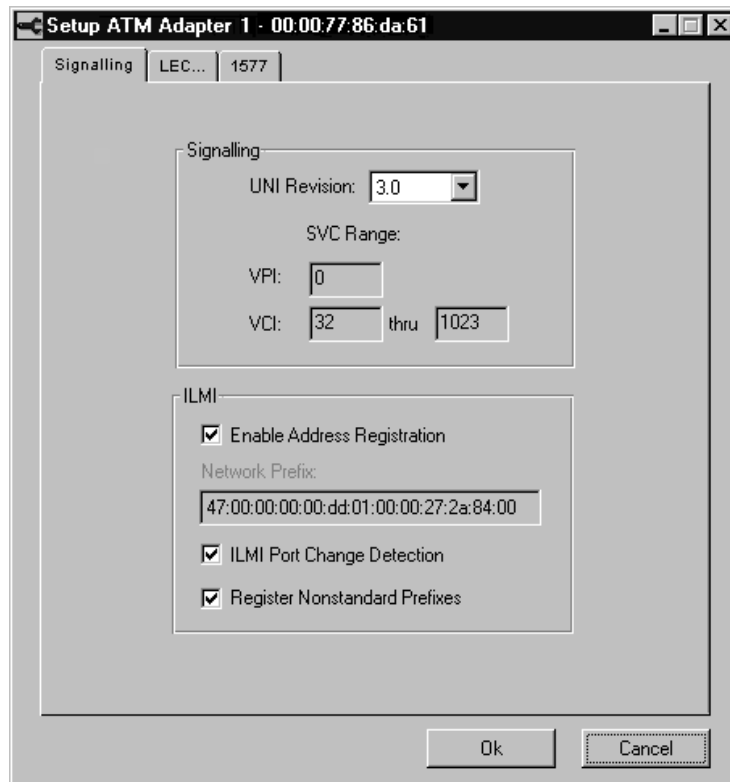

Figure 4-3. CellView Signalling Setup

2. Provide information in the Signalling dialog fields, as follows:

Use this field...	To do this...
UNI Revision	Select the UNI revision (UNI 3.0 or UNI 3.1).
SVC Range: VPI (Virtual Path Identifier)	Determine the VPI available to the driver for SVCs. The VPI is a one-byte field in the ATM cell header that, when combined with the VCI, forms an ATM address. At present, only VPI 0 is supported.

Setup

Use this field...	To do this...
SVC Range: VCI (Virtual Circuit Identifier)	Determine the range of VCIs available to the driver for SVCs. The range is fixed and cannot be edited. In the sample dialog (Figure 4-3 on page 37), circuits 0–31 are reserved for system communications. Circuits 32–1023 are available for station-to-station traffic.
Enable Address Registration	Enable the adapter to acquire its 13-byte network prefix at bootup from the switch. Disable this feature if your switch does not support address registration.
Network Prefix	Display or enter the adapter's 13-byte network prefix. If the Enable Address Registration feature is enabled, the network prefix is entered automatically at bootup, and is display-only. If the Enable Address Registration feature is disabled, obtain the network prefix from the switch and enter it manually.
ILMI Port Change Detection	Enable the adapter to poll the ATM switch every 30 seconds, to advise it is up and running. At bootup, the switch adds the host station to the active stations list. If the host station is turned off, polling stops, and the switch removes the host from this list. Disable this feature if your switch does not support ILMI polling.
Register Nonstandard Prefixes	Enable the ILMI to register the ATM Forum's well-known address for the LECS with the switch. The prefix in the well-known address usually differs from the ATM prefix for the adapter. Some switches might not support the registration of different prefixes through a single port. Disable this setting if your switch does not support mixed prefixes.

In UNIX-based systems, you must restart signalling for signalling setup changes to take effect.

- In IRIX operating systems, restart signalling with the command: `sigd_start`
- In other UNIX operating systems, restart signalling with the command: `restart_sigald`

Setting Up LAN Emulation Clients

The driver allows up to four clients per adapter to be enabled at a time. You must enable and fully configure at least one LAN emulation client (LEC) or an IP over ATM client before running applications on the network. Other clients are optional, and can be enabled at any time.

CellView provides a separate tabbed LEC dialog for each LEC setup. Using the LEC dialogs, you can set parameters for each LEC to establish communications with a LAN Emulation Configuration Server (LECS) at bootup, or to contact a LAN Emulation Server (LES) directly. You can also set up PVC links with other endstations. Changes to the LEC dialogs are dynamic, and take effect when you click **OK**.

To set up a LEC:

1. On the main CellView dialog, highlight the adapter you want to configure.
2. Select **Setup**, and then select the **LEC...** tab.
3. Select the **LEC<x>** tab (where <x> is the number of the LEC you are configuring) to display the appropriate LEC dialog:

Setup

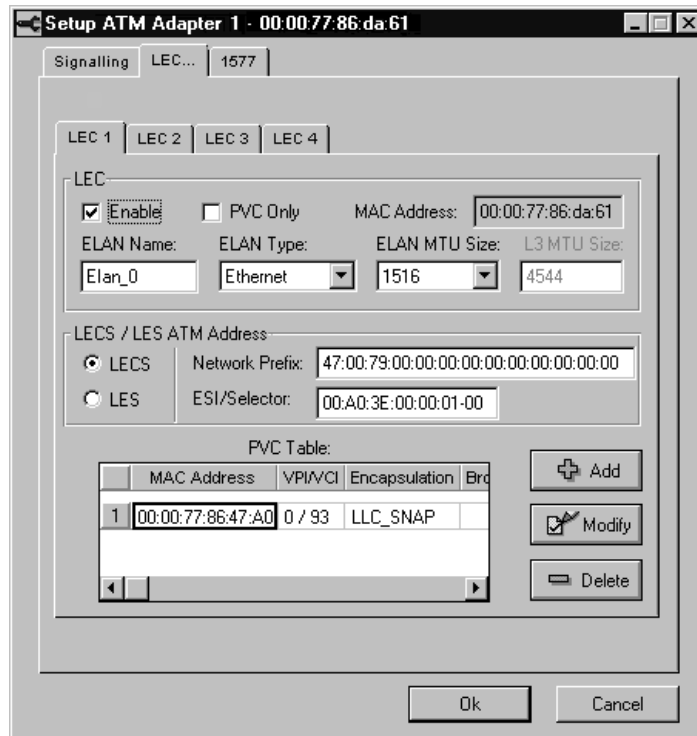

Figure 4-4. CellView LEC Setup

4. Enter information in the LEC dialog fields to configure the following:
 - LEC settings and LECS/LES ATM address settings
 - LEC PVC settings

The following topics provide information about configuring these settings.

LEC and LECS/LES ATM Address Settings

To configure LEC settings and LECS/LES ATM address settings, provide information in LEC dialog fields, as follows:

Use this field...	To do this...
Enable	Enable the LEC.
PVC Only	Set up PVC communications without enabling SVC activity. For PVC-only clients, the only other settings you need to configure are the L3MTU Size and the PVC Table.
MAC Address	(Display-only.) Determine the MAC address of the LEC. LEC 1 is assigned the base address for the adapter. The remaining LECs use increments of the base address for their MAC addresses. If the LEC is enabled as Token Ring, the MAC Address is displayed in non-canonical format.
ELAN Name	Identify the network name of the emulated LAN you want the client to join. Some configuration servers require a name while others do not. The Interphase LECS and LESs require a name only in the following cases: The Strict ELAN Name field is enabled on the LES dialog. You need to differentiate between two or more LESs with the same MTU size and ELAN type. For exact requirements, see your server documentation. For information about setting up Interphase servers, see <i>Setting Up a LAN Emulation Configuration Server</i> on page 50.
ELAN Type	Select the ELAN type (Ethernet or Token Ring).

Setup

Use this field...	To do this...
ELAN MTU Size	<p>Select the requested ELAN MTU size. The client uses this entry when making a request to join a LES. The MTU returned to the client is equal to or less than the requested value.</p> <p>Recommended settings are:</p> <p>ELAN with Ethernet edge device: 1516</p> <p>ELAN with Token Ring edge device: 4544</p> <p>ELAN with ATM endstations only: 9234</p> <p>All nodes on the same logical subnet must use the same MTU size.</p>
L3MTU Size	<p>Force the MTU size to the entered value, rather than the value returned by the LANE server (LES). Done only for values other than zero (0).</p> <p>If the client is in PVC-Only mode (no LANE services), you must set the L3MTU size to the IP MTU of the network.</p> <p>If the MTU is not based on the MAC layer, you must set the L3MTU size to the actual IP MTU of the network. For example, if the ELAN MTU Size of a Token Ring network is 4544, but the IP MTU is 2048, set the L3MTU Size to 2048.</p>
LECS/LES ATM Address	<p>Select the mode of contact at bootup:</p> <p>LECS contacts the LES with the 20-byte ATM address in the Network Prefix and ESI/Selector fields. (The default address is the ATM Forum's well-known address.)</p> <p>LES uses the 20-byte address in the ATM address fields to contact a LES directly.</p>

LEC PVC Settings

Use the PVC Table in the LEC dialog to set permanent virtual connections (PVCs) between a client and other network endstations. Figure 4-5 illustrates the PVC Table for LECs:

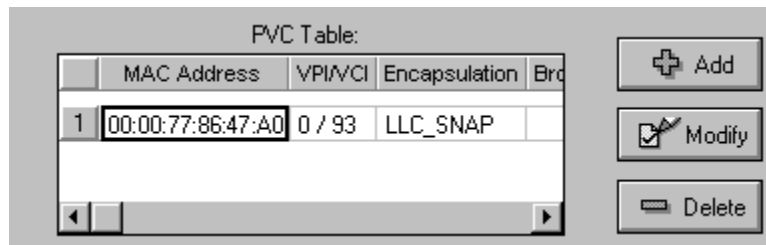

Figure 4-5. PVC Table in LEC Dialog

A 6-byte MAC address and a VCI number are associated with each PVC. Packets from the upper layers whose destination MAC addresses match an address in the PVC table are transmitted on that PVC.

In addition to providing setup information in the PVC Table, you must also consider the following when configuring PVCs for LECs:

- All PVCs must be configured in the adapters and the switch(es) manually.
- The MAC address of the target station must be mapped to a VCI in the local host.
- The MAC address of the local client must be mapped to a VCI in the target station.

You can use buttons in the PVC table block to add, modify, or delete PVC table entries, as described in the following topics.

Setup

Adding or Modifying LEC PVC Table Entries

To add or modify PVC table entries for the LEC:

1. Select **Add** to add a PVC setting, or highlight the appropriate entry and select **Modify** to revise a PVC setting.

The following dialog appears:

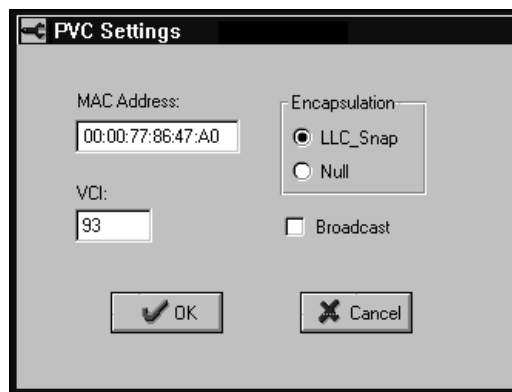

Figure 4-6. PVC Settings for LECs

2. Provide information in the PVC Settings dialog fields, as follows:

Use this field...	To do this...
MAC Address	Enter the 6-byte address of the target station. Use the natural format for the ELAN. For example, for a Token Ring ELAN, use non-canonical format.

Use this field...	To do this...
VCI	Identify the VCI number the LEC uses to communicate with the target. To determine the range of VCIs available, go to the Setup dialog for Signalling, and check the SVC Range in the VCI fields (Figure 4-3 on page 37). In most cases, the range is 32–1023. (The corresponding VPI cannot be edited and is fixed at a value of zero.)
Encapsulation	Select the encapsulation method (LLC_Snap or Null). The host and target must use the same encapsulation method. See <i>Multiprotocol Encapsulation over ATM AAL5</i> on page 154 for an explanation of these encapsulation methods.
Broadcast	Enable the entry as a Broadcast PVC. If enabled, all broadcast/multicast packets from the upper layers are transmitted on this PVC. A maximum of 16 Broadcast PVCs can be enabled on each LEC.

Deleting LEC PVC Table Entries

To delete a PVC table entry, highlight the entry, and select **Delete**.

Setting Up IP over ATM Client and Server

The IP over ATM client conforms to the RFC-1577 specification using Classical IP over ATM where no multicast or broadcast services are available.

Setup

Using the 1577 dialog, you can enable the Classical IP over ATM client and enable the host adapter as the Address Resolution Protocol (ARP) server for the network. You can also set up PVC links with other endstations. Changes to the 1577 dialog are dynamic, and take effect when you click **OK**.

To set up an IP over ATM client/ARP server configuration:

1. On the main CellView dialog, highlight the adapter you want to configure.
2. Select **Setup**, and then select the **1577** tab to display the IP over ATM dialog:

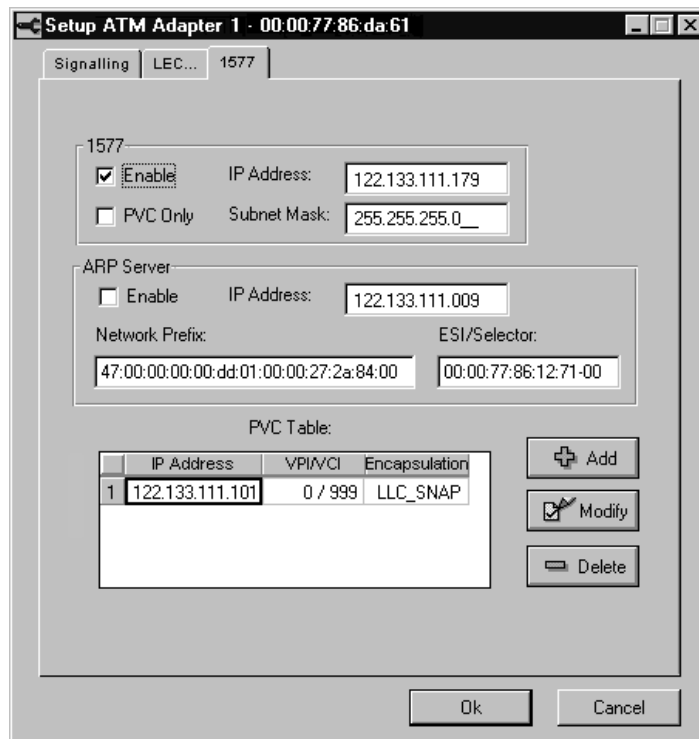

Figure 4-7. CellView IP over ATM Setup

3. Enter information in the 1577 dialog fields to configure the following:

- IP over ATM client and ARP server settings
- IP over ATM PVC settings

The following topics provide information about configuring these settings.

IP over ATM Client and ARP Server Settings

To configure IP over ATM client and ARP server settings, provide information in 1577 dialog fields, as follows:

Use this field...	To do this...
Enable	Enable the Classical IP over ATM client.
PVC Only	Set up PVC communications without enabling the SVC IP over ATM client activity. For PVC-only clients, the only other settings you need to configure are the PVC Table settings.
IP Address	Verify or enter the client's IP address.
Subnet Mask	Verify or enter the client's subnet mask identifier.
ARP Server: Enable	Enable the host adapter as the ARP server for your IP over ATM network.
ARP Server: IP Address	If the host adapter is not the ARP server, enter the IP address of the ARP server located elsewhere in the network.
ARP Server: Network Prefix and ESI/Selector	If the host adapter is not the ARP server, enter the ARP server's ATM address, which consists of the Network Prefix and ESI/Selector. (For details about the address structure, see <i>ATM Address</i> on page 31.) The IP over ATM driver must know the ATM address of the ARP server. When the system is powered up, it calls the ARP server with this ATM address.

*Setup***IP over ATM PVC Settings**

Use the PVC Table in the 1577 dialog to set permanent virtual connections (PVCs) between the local client and other end stations in the IP over ATM subnet. Figure 4-8 illustrates the PVC Table for IP over ATM clients:

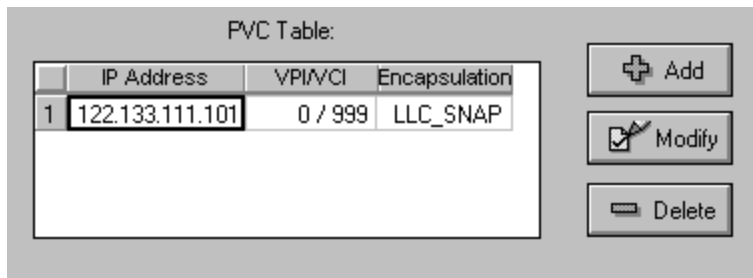

Figure 4-8. PVC Table in 1577 Dialog

In addition to providing setup information in the PVC Table, you must also consider the following when configuring PVCs for the IP over ATM client:

- All PVCs must be configured in the adapters and the switch(es) manually.
- The IP address of the target station must be mapped to a VCI in the local host.
- The IP address of the local client must be mapped to a VCI in the target station.

You can use buttons in the PVC table block to add, modify, or delete PVC table entries, as described in the following topics.

Adding/Modifying IP over ATM PVC Table Entries

To add or modify PVC table entries for an IP over ATM client:

1. Select **Add** to add a PVC setting, or highlight the appropriate entry and select **Modify** to revise a PVC setting.

The following dialog appears:

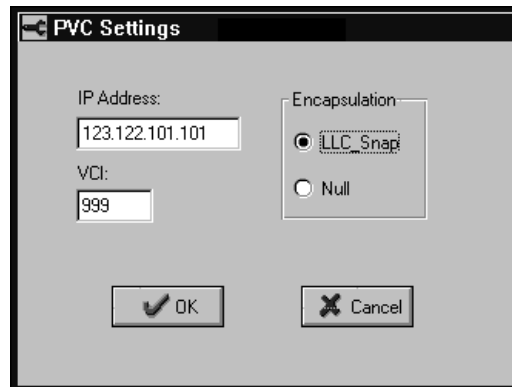

Figure 4-9. PVC Settings for IP over ATM

2. Provide information in the PVC Settings dialog fields, as follows:

Use this field...	To do this...
IP Address	Enter the IP address of the target station.
VCI	Identify the VCI number the IP over ATM client uses to communicate with the target. To determine the range of VCIs available, go to the Setup dialog for Signalling, and check the SVC Range in the VCI fields (Figure 4-3 on page 37). In most cases, the range is 32–1023. (The corresponding VPI cannot be edited and is fixed at a value of zero.)
Encapsulation	Select the encapsulation method (LLC_Snap or Null). The host and target must use the same encapsulation method. See <i>Multiprotocol Encapsulation over ATM AAL5</i> on page 154 for an explanation of these encapsulation methods.

Setup

Deleting IP over ATM PVC Table Entries

To delete a PVC table entry, highlight the entry, and select **Delete**.

Setting Up a LAN Emulation Configuration Server

To communicate on an ATM network, a LEC must join an emulated LAN (ELAN). The ELAN consists of a group of endstations which communicate among themselves with the same MTU size, the same frame format, and the same broadcast/multicast services. The LAN Emulation Server (LES) is the central server for the ELAN. The LAN Emulation Configuration Server (LECS) manages which LEC joins which LES.

The LECS must reside on the ATM adapter with the LESs it serves; it cannot communicate with LESs across the network. You must enable the LECS and associated LESs before configuring the LECs that join LESs.

The LECS provides a central point of contact on the network for LECs at bootup. At bootup, the LEC sends the LECS a request for the type of ELAN it wants to join. The LECS responds with the current ATM address and the configuration parameters of the LES that serves the requested ELAN.

To set up the LECS:

1. If the LECS tab is not available, select **Global** from the main CellView dialog to display the Application Dialog. Then enable the **Enable Advanced Settings** field and click **OK**.
2. On the main CellView dialog, highlight the adapter you want to configure.

3. Select **Setup**, and then select the **LECS** tab to display the LECS dialog:

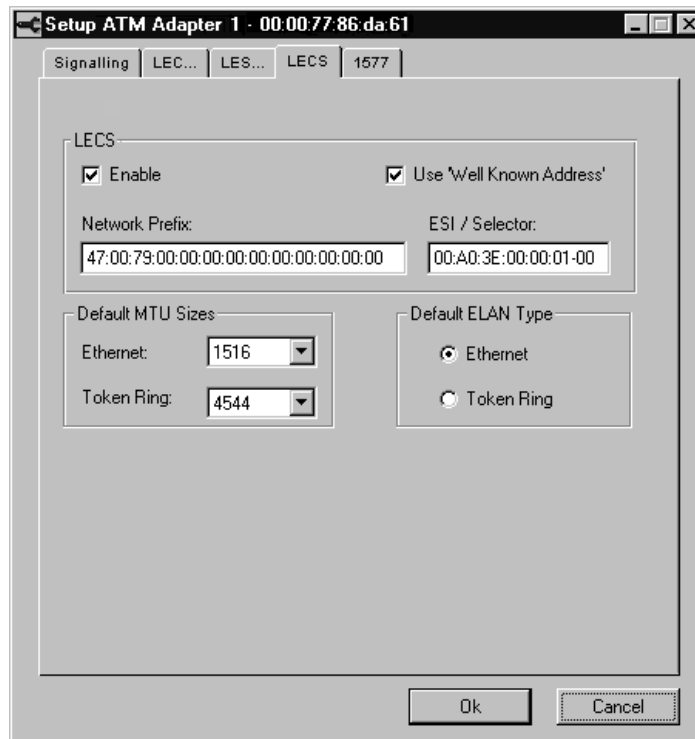

Figure 4-10. CellView LECS Setup

4. Provide information in the LECS dialog fields, as follows:

Use this field...	To do this...
Enable	Enable the LECS and all permanent mappings of LECs to specific LESs.

Setup

Use this field...	To do this...
Use 'Well Known Address'	Enable the loading of the ATM Forum's well-known address to the Network Prefix and ESI/Selector fields. When enabled, these address fields cannot be edited.
Default MTU Sizes	Select the default Ethernet or Token Ring ELAN MTU size to assign to an LEC if the LEC's configuration request omits the MTU size. If the request also omits the ELAN type, the LECS will attempt to assign the LEC to a LES of the Default ELAN Type with an MTU size equal to or less than the requested size.
Default ELAN Type	Select a default ELAN type to assign to an LEC if the LEC's configuration request omits the ELAN type. The LECS will attempt to assign the LEC to a LES of the Default ELAN Type with an MTU size equal to or less than the requested size.

Changes to the LECS dialog are dynamic, and take effect when you click **OK**.

Setting Up a LAN Emulation Server

To communicate on an ATM network, a LEC must join an emulated LAN (ELAN). The ELAN consists of a group of endstations which communicate among themselves with the same MTU size, the same frame format, and the same broadcast/multicast services. The LAN Emulation Server (LES) is the central server for the ELAN. It provides address registration, address resolution, and broadcast services for all ELAN members. The LAN Emulation Configuration Server (LECS) manages which LEC joins which LES.

The driver allows up to eight LESs to be enabled per adapter at one time (therefore allowing adapter support for up to eight ELANs). The LESs must reside on the same ATM adapter with the LECS that serves them; they cannot communicate with the LECS across the network. You must enable a LES and its associated LECS before configuring LECs to join the LES.

When a LEC joins a LES, the MAC-ATM relationship of the client is registered with the LES. The LES maintains a running account of these addresses to resolve queries from ELAN members. The connection between the LES and each LEC is a permanent, open connection as long as the client is running.

The LES maintains a table of client information that it uses to provide address resolution services to the ELAN. When an endstation is disconnected or turned off, the LES removes client(s) from the table automatically. Therefore, relocating an endstation is a matter of physically moving the hardware and connecting it to the same or another ATM switch. At bootup, the client(s) rejoin the previous LES with a new ATM address.

CellView provides a separate tabbed LES dialog for each LES-ELAN setup. Changes to the LES dialogs are dynamic, and take effect when you click **OK**.

To set up a LES:

1. If the LES... tab is not available, select **Global** from the main CellView dialog to display the Application Dialog. Then enable the **Enable Advanced Settings** field, and click **OK**.
2. On the main CellView dialog, highlight the adapter you want to configure.
3. Select **Setup**, and then select the **LES...** tab.

Setup

4. Select the **LES<x>** tab (where <x> is the number of the LES you are configuring) to display the appropriate LES dialog:

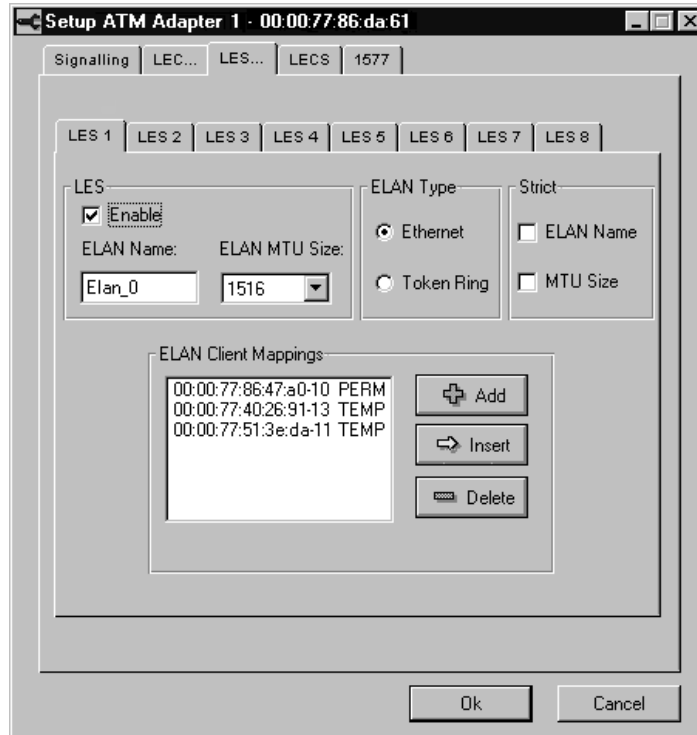

Figure 4-11. CellView LES Setup

5. Enter information in the LES dialog fields to configure the following:
 - LES settings
 - ELAN Client Mappings settings

The following topics provide information about configuring these settings.

LES Settings

To configure LES settings, provide information in LES dialog fields, as follows:

Use this field...	To do this...
Enable	Enable the LES.
ELAN Name	Enter the name of the ELAN for which the LES provides services (not required for a LEC to join the group). If the ELAN Name setting in the Strict block is enabled, the ELAN name in the LEC request must exactly match this name (case sensitive). Otherwise, the server prevents the LEC from joining the group.
ELAN MTU Size	Select the MTU size for the ELAN for which the LES provides services. Recommended options are: ELAN with Ethernet edge device: 1516 ELAN with Token Ring edge device: 4544 ELAN with ATM endstations only: 9234 If the MTU Size setting in the Strict block is enabled, the request from the LEC must exactly match the ELAN MTU Size. Otherwise, the server prevents the LEC from joining the group.
ELAN Type	Select the ELAN type (Ethernet or Token Ring) to use for all communications between endstations. If the ELAN includes an edge device to a legacy LAN, the ELAN type must be set to interface with that edge device.
Strict: ELAN Name	Specify the ELAN Name in the LEC's request must exactly match the entry in the ELAN Name text field on this dialog (case sensitive).
Strict: MTU Size	Specify the ELAN MTU Size in the LEC's request must exactly match the entry in the ELAN MTU Size selection field on this dialog.

Setup

ELAN Client Mappings Settings

The ELAN Client Mappings block of the LES dialog shows the ESI/Selector value for each LEC currently assigned to the LES. The clients can be *permanently* or *temporarily* assigned to the LES, based on settings configured in this LES dialog or in the LEC dialog. Figure 4-12 illustrates the ELAN Client Mappings block:

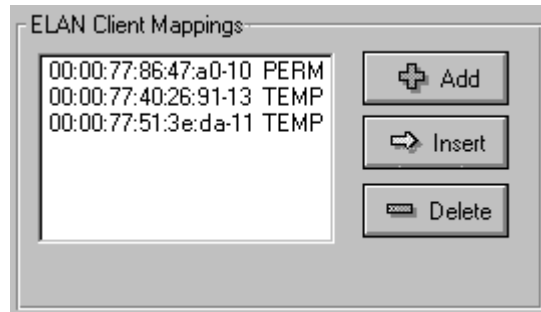

Figure 4-12. ELAN Client Mappings Table in LES Dialog

ELAN Client Mappings use two client classifications:

- **PERM** means the client is permanently assigned to the LES (using the Add or Insert button on this dialog). A permanently-assigned client can join only its assigned LES. This gives network administrators control in assigning clients to specific ELANs.
- **TEMP** means the client is temporarily assigned to the LES based on the configuration parameters requested by the client. This entry is removed when the client leaves the ELAN.

The ELAN Client Mappings table obtains the list of permanently-assigned clients from a table maintained by the LECS. When the LECS is enabled, it checks for a permanent

status each time a client attempts to join the network, regardless of whether the client is configured to contact the LECS or directly contact a LES.

Use the ELAN Client Mappings block of the LES dialog to permanently assign or remove LES client assignments.

Both the Add and Insert buttons in the ELAN Client Mappings block enable you to permanently assign clients to the LES.

- Use the **Add** button to enter the client's ESI/Selector value.
- If the client is currently assigned or running on another ELAN, it is more convenient to use the **Insert** button to move the client to this LES.

You can permanently assign a client which is permanently assigned to another LES, temporarily assigned to another LES, or currently not a member of any ELAN.

Adding a Client

To add a client to a LES:

1. Select **Add** to display the following dialog:

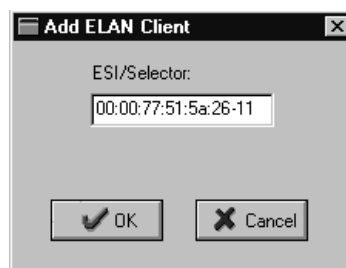

Figure 4-13. Add Permanent Clients to a LES

2. Enter the ESI/Selector value for the client.

If you are not familiar with the structure of this address, see *ATM Address* on page 31.

Setup

3. Select OK.

This procedure permanently adds the new entry to the LES's ELAN Client Mappings table. Also, if the client was a member of another ELAN, this procedure removes the client from that ELAN's LES. When the client attempts to join the network again, it can join only the newly assigned LES.

Inserting Clients

To move clients from another LES to the LES being configured:

1. Select **Insert** to display the following dialog:

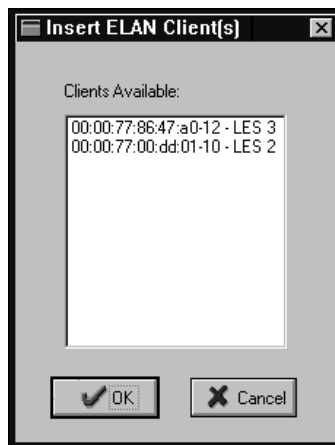

Figure 4-14. Insert Permanent Clients

This dialog lists all permanent and temporary clients that are assigned to other LESs.

2. Highlight the clients you want to move to the LES being configured, and select **OK**.

This procedure permanently adds the new entries to the LES's ELAN Client Mappings table and removes the client from other LESs.

Deleting a Client

To remove a client from the LES, highlight the client in the ELAN Client Mappings block, and select **Delete**.

If the client was permanently assigned, it is removed from the ELAN served by the LES and from the table of permanent clients maintained by the LECS. It can attempt to join the network again any time after deletion.

If the client was temporarily assigned, it is removed from the ELAN served by the LES. When it attempts to join the network again, it will be assigned to a LES based on requested parameters. (This will be the same LES unless changed in the LEC Setup dialog since the last startup.)

Statistics

The dialogs in the Statistics group are provided to assist you and Interphase support personnel with troubleshooting ATM network problems. Limited procedures for using the dialogs are included in the troubleshooting sections of this Users Guide. CellView can gather operating statistics for local Interphase clients and servers only. It cannot gather statistics from switches or from other endstations.

If the LECS and LESs are located on this adapter, to see the statistics for the servers, enable the **Enable Advanced Settings** feature (in the Application dialog of Global settings).

Global Settings

Settings for global routines control CellView parameters that are common to all adapters. You are not required to restart endstations to make global settings take effect. Use Global settings to:

Global Settings

- Control application display settings
- Display signalling connection settings in drivers
- Produce information to use for debugging

The following table identifies where to find information about CellView Global tasks:

For information about...	See page...
Controlling Application Display Settings	60
Displaying Signalling Connections Settings	61
Producing Debugging Messages	63

Controlling Application Display Settings

Use the Application dialog to control display settings for CellView Setup and Statistics routines, such as refresh rates and tabbed dialogs available for setup and statistics routines.

To control display settings:

1. From the main CellView dialog, select **Global** to display the Application dialog:

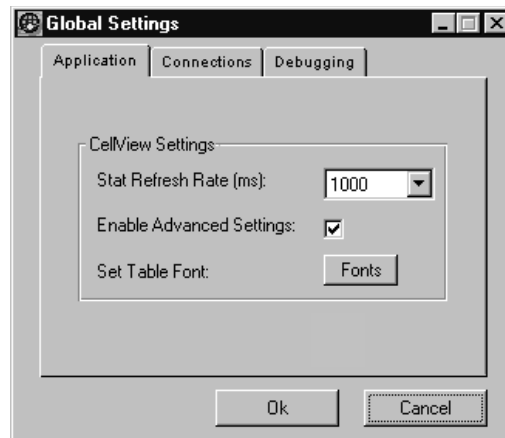

Figure 4-15. CellView Global Application

2. Provide information in Application dialog fields, as follows:

Use this field...	To do this...
Stat Refresh Rate	Control the update or refresh rate, in milliseconds, of the data fields in the Statistics dialogs.
Enable Advanced Settings	Activate the tabs for the LECS and the LES in the Setup and Statistics dialogs. This setting does not affect the enable/disable condition of the ELAN servers. The tabs can be hidden from view while the servers remain enabled.
Set Table Font	Select the font used for tables in dialogs.

Displaying Signalling Connections Settings

Use the Connections dialog to display the signalling connections configuration in adapter drivers. Currently, these settings cannot be changed; they are preset in the drivers.

Global Settings

To display the Connections dialog, select **Global** from the main CellView dialog, and then select the **Connections** tab:

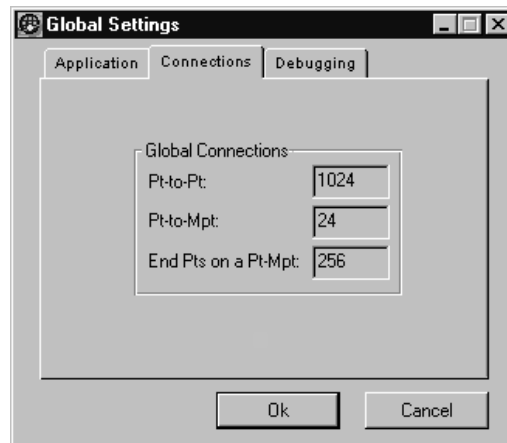

Figure 4-16. CellView Global Connections

The following table describes Connections dialog fields:

Use this field...	To do this...
Pt-to-Pt	Display the maximum number of SVC connections with other endstations that are allowed simultaneously.
Pt-to-Mpt	Display the maximum number of SVC multipoint connections that are allowed simultaneously. These are used primarily between LECs and a LES/BUS.
End Pts on a Pt-Mpt	Display the maximum number of end points on each multipoint connection. This affects the number of clients allowed on the same ELAN.

Producing Debugging Messages

Use the Debugging dialog as a troubleshooting aid for the adapter. If you have difficulty establishing connections with other network nodes or establishing ILMI connectivity with the switch, enable the appropriate debug options. The debug options produce signalling debug messages from various modules to help isolate the problem. Be sure to disable the options when debugging is complete.

To produce Debugging messages:

1. From the main CellView dialog, select **Global**, and then select the **Debugging** tab.



Figure 4-17. CellView Debugging Options

Global Settings

2. Select Debugging dialog options, as follows:

Use this field...	To do this...
API	Track the Signalling Application Program Interface (API). These are the routines used by the applications software to manage SVCs.
Signalling	Track the Signalling PDUs exchanged by the host Signalling and the switch.
ILMI	Track the IME PDUs exchanged by the host Signalling and the switch. Useful in debugging ILMI Address Registration problems.

NetWare Server Driver Installation

5

Overview

This chapter contains the procedures for installing the PCI ATM driver on file servers running Novell NetWare version 3.12, 4.10, or 4.11. The driver is for Switched Virtual Circuits using the User-Network Interface (UNI) 3.0/3.1 signalling specification. The communication links between nodes are set up and torn down dynamically for each transmission of data.

The driver complies with the ATM Forum LAN Emulation specification version 1.0 which provides broadcast/multicast addressing, allowing you to run legacy LAN (Ethernet, Token Ring, and FDDI) applications and protocols over an ATM network. The driver supports multiple Emulated LANs (ELANs) in a single board can belong to four different ELANs simultaneously.

The Interphase software supports the following:

- Up to four PCI ATM adapters per system
- Up to four LECs (LAN Emulation Clients) per adapter using both SVC and PVC communications.
- One of the above LECs can be changed to an IP over ATM client using both SVC and PVC communications
- Optional Network Services
 - Up to eight LESs (LAN Emulation Servers) on the same adapter as the LECS
 - One LECS (LAN Emulation Configuration Server) on the same adapter as the LESs
 - One IP over ATM server per adapter

Driver Requirements

During installation, up to four LECs can be assigned to an adapter. One of these clients can be set as an IP over ATM client (based on RFC-1577), plus all clients can be set to use PVC communications based on RFC 1483. After installation, the clients and LAN services are configured to your network with the *CellView Utility for NetWare Servers* on page 87.

If any *Read Me First* documentation is in your installation kit, read it before installing the driver. It contains any changes and updates to this users guide since the printing date. Also, check for a README file in the NetWare directory on the installation CD-ROM. If you are not thoroughly familiar with ATM networking, read the tutorial *ATM Technology Overview* on page 133.

The basic steps for installing this driver are:

- Verify the driver requirements
- Install the driver
- Initialize the clients
- Configure the AUTOEXEC.NCF file
- Add drivers for additional adapters (if applicable)

Driver Requirements

The NetWare file server must meet the following minimum requirements:

- Intel x86 CPU file server running Novell NetWare version 3.12, 4.10, or 4.11
- CD-ROM drive
- 2 MB of free space on the hard disk
- System memory
 - 20 MB minimum

- up to 32 MB with multiple clients and LAN services enabled
- TCP/IP interface (if applicable)
 - IP address for each enabled client
 - IP mask

Installing the Driver



CAUTION

If an earlier version of an Interphase PCI ATM adapter driver is installed on the server, you must remove it before proceeding with the new driver. See the section *Removing a Driver* on page 85 for instructions.



NOTE

If TCP/IP is not installed on the server and one or more of the clients are to use this protocol, you should install TCP/IP on the server before installing the ATM driver.

To install the driver, do the following:

1. With the file server up and running, enter the command:
`load install`
2. When the Installation Options dialog appears, select **Driver Options**, and then select **Configure network drivers**.

Installing the Driver

3. In the Additional Driver Actions dialog, select **Select an additional driver.**

The Select A Driver dialog appears. If this is your first installation of the driver, it does not appear in the list.

4. If the driver you want to install does not appear, press **Insert.**

A system prompt appears for changing the installation path.

5. Insert the Interphase installation CD-ROM.

6. Press **F3 and set the path to:**

<drv>:\NetWare

where <drv> is the drive letter of the CD-ROM.

7. Press **Enter.**

A dialog appears, listing the contents of the NetWare directory.

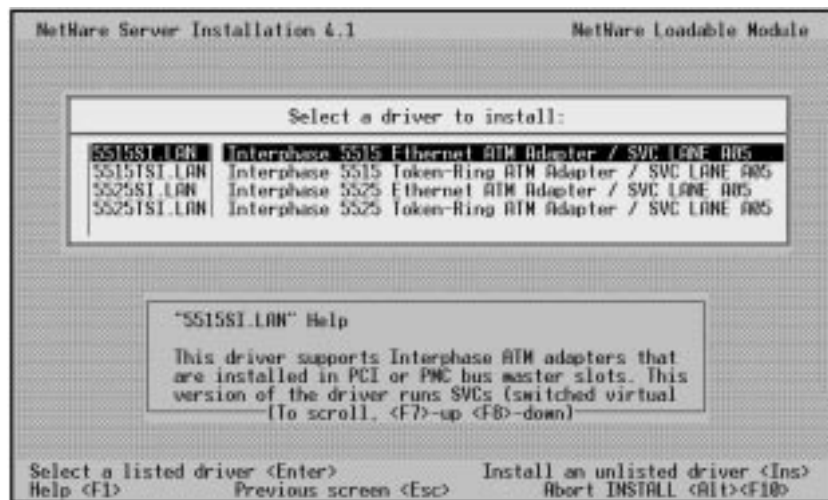

Figure 5-1. Selecting a Driver



CAUTION

Ethernet and Token Ring drivers cannot be mixed on the same machine. You must use the same frame type for all channels on all adapters which are installed in the NetWare server.

8. Select the driver which matches the speed of the adapter and the type of framing for the network:

Driver	Adapter	Frame Type
5515SI.LAN	155 Mbps (5515 or 5575)	Ethernet
5515TSI.LAN	155 Mbps (5515 or 5575)	Token Ring
5525SI.LAN	25 Mbps (5525)	Ethernet
5525TSI.LAN	25 Mbps (5525)	Token Ring

9. Confirm the name of the driver and select **Yes**.

The driver files are copied to the NetWare server.

Continue the installation with the procedure in the next section.

Configuring Protocols and Parameters

After the driver files are copied to the NetWare server, as initiated in the previous section, a dialog appears similar to the following:

Configuring Protocols and Parameters



Figure 5-2. Protocols/Parameters Configuration

The driver names, located in the box titles, contain the increment of the client being configured. If this is the second installation of the driver, the titles read 5515SI_2 for Client 2, and so forth.

To configure the protocols and parameters for the adapter, do the following:

1. Select **Select/Modify driver parameters & protocols** at the bottom of the dialog.
The highlight moves to TCP/IP in the Protocols box.
If this LEC is to use TCP/IP or this client is to be an IP over ATM client, you must add the protocol to the client with the next step.
2. If you need to add TCP/IP or AppleTalk, do the following:
 - a. Select the protocol you want to enable.

8. Press **Enter** to accept the binding number.



NOTE

It is recommended you initialize all four clients on the adapter. Disabled clients use minimal resources compared to the tasks of initializing clients at some later date.

9. When the prompt appears for loading the driver for an additional channel, **do one of the following:**

- If you do not want to initialize another client, select **No**, return to the initial Installation Options dialog, and skip to the next section *Editing Maximum Packet Size* on page 73
- If you want to initialize another client, select **Yes**. The maximum is four clients (Client 1 plus three additional clients).

The dialog shown in Figure 5-1 on page 68 reappears. This time, however, the driver is obtained from your hard disk instead of the CD-ROM.

10. Select the same driver you installed for the previous client.

Ethernet and Token Ring cannot be mixed on the same machine.

11. Repeat the configuration procedures for the new client beginning with step 1 on page 70.

Continue the installation with the next section.

Editing Maximum Packet Size

If any of the clients are to use an MTU size larger than 1516, you must edit the `STARTUP.NCF` file to accommodate the larger framing size.

To change the maximum packet size for the system, do the following:

1. With the NetWare `install` utility up and running, go to the initial Installation Options dialog, if you are not there already.
2. Select **NCF files** option, then select **Edit the startup.ncf** to open the file for editing.
3. Modify or add the line:

```
SET maximum physical receive packet size=<mtu>
```

where `<mtu>` is set to 1516, 4544, or 9234.

The recommended usage for each size is as follows:

- ELAN with Ethernet edge device: 1516 (default)
- ELAN with Token Ring edge device: 4544
- ELAN with ATM endstations only: 9234



CAUTION

The maximum packet size in the `STARTUP.NCF` file must be equal to or greater than the largest MTU size used for any LEC or IP over ATM client.

4. Save and exit the `STARTUP.NCF` file.

Continue the installation with the next section.

Editing AUTOEXEC.NCF

The commands and parameters in the `AUTOEXEC.NCF` file are used to configure the system components at bootup. For ATM networking, you can automate the ATM startup, change the default parameters for the clients, add commands for multiple adapters, and so forth.

The topics in this section are presented in the order in which they should be configured during the initial installation of the driver. You can return at a later time to any of the topics and change them as needed to meet your network requirements. In all cases, reboot the server upon saving and exiting the file.

To edit the `AUTOEXEC.NCF` file, do the following:

1. With the NetWare `install` utility up and running, go to the initial Installation Options dialog, if you are not there already.
2. Select **NCF files** option, then select **Edit the autoexec.ncf** to open the file for editing.

The following table identifies where to find the information for configuring the commands and parameters in the `AUTOEXEC.NCF` file:

For information about...	See page...
Formatting Commands	75
Automating ATM Startup	78
Editing MTU Size	78
Editing UNI Signalling	80
Changing a LEC to an IP over ATM Client	80
Configuring Multiple Adapters	82

If you are not thoroughly familiar with the `LOAD` and `BIND` commands used to configure the ATM clients at bootup, see the following section. Otherwise, continue the installation of the driver with the procedures in *Automating ATM Startup* on page 78.

Formatting Commands

The format of the `LOAD` command (all on one line) is as follows:

```
LOAD <driver> \
    CHANNEL=<channel_number> \
    UNI=(3.0 or 3.1) \
    ELAN=<network_name> \
    FRAME=<frame_type> \
    NAME=<channel_name> \
    SLOT=<slot_number> \
    MTU=(1, 4, or 9) \
    IPENABLE=(Y or N)
```

Table 5-1. LOAD Command Variables

Variable	Description
<driver>	The name of the driver should not change unless the speed of the adapters are different. Ethernet and Token Ring cannot be mixed on the same machine.
CHANNEL	The client number for the adapter. Range of <channel_number> is 1 – 4.
UNI	Set to 3.1 for UNI signalling specification 3.1. If not set to 3.1 or the variable does not appear in the command, the driver assumes UNI version 3.0.

Table 5-1. LOAD Command Variables (continued)

Variable	Description
ELAN	The name of the emulated LAN for which this client is the NetWare server.
FRAME	The four options for Ethernet drivers are: FRAME=Ethernet_802.2 FRAME=Ethernet_802.3 FRAME=Ethernet_II FRAME=Ethernet_Snap For Token Ring drivers, use the parameter FRAME=Token-Ring
NAME	Each client must have a unique name for binding the protocol to the driver.
SLOT	The number of the slot in which the adapter is located.
MTU	All nodes on the same logical subnet must use the same MTU size. The three options for a client are 1, 4, or 9 with the following recommendations: 1 = 1516 for ELAN with Ethernet edge device 4 = 4544 for ELAN with Token Ring edge device 9 = 9234 for ELAN with ATM endstations only If the MTU variable does not appear in the command, the driver uses a setting of MTU=1. If the MTU is set to 4 or 9, the maximum packet size for the system must be set to accommodate the larger framing size. For more information, see <i>Editing Maximum Packet Size</i> on page 73.
IPENABLE	Set to Y for IP over ATM client. If not set to Y or the variable does not appear in the command, the driver initiates LEC activity.

The format of the `BIND` command for IPX is as follows:

```

BIND IPX to <channel_name> NET=<elan_number>

```

Table 5-2. IPX BIND Command Variables

Variable	Description
<channel_name>	The NAME of the channel in the previous LOAD command for which you want to bind the IPX protocol.
NET	The unique identification number in hex format for the emulated LAN.

The format of the BIND command (all on one line) for TCP/IP is as follows:

```

BIND IP to <channel_name> \
  ARP=<enable_arp> \
  ADDRESS=<IP_address> \
  MASK=<net_mask>

```

Table 5-3. TCP/IP BIND Command Variables

Variable	Description
<channel_name>	The NAME of the client in the previous LOAD command for which you want to bind the IP protocol.
ARP	Enables or disables the ARP protocol. The two settings for <enable_arp> are Yes to enable and No to disable.
ADDRESS	The Internet address for the channel. The format is dotted decimal notation in the form xxx.xxx.xxx.xxx, where xxx ranges from 0 to 254.
MASK	The most commonly used mask is ff.ff.ff.0, or 255.255.255.0 in decimal notation.

Continue the installation with the next section.

Automating ATM Startup

A few commands need to be added to the `AUTOEXEC.NCF` file in order to automate the ATM requirements at boot time. If not added to the file, the commands have to be entered manually each time the NetWare server is started.

To automate ATM startup, do the following

1. Find the last `BIND` command for a client in the `AUTOEXEC.NCF` file.

For example, if Client 1 through Client 4 are initialized, the last `BIND` command should be similar to:

```
BIND IPX 5515SI_4 NET=<random_8_digits>
```

2. Insert the following commands in the line immediately following the last `BIND` command:

```
LOAD asig  
LOAD cvconf
```

3. If TCP/IP is installed on the NetWare server, check and make sure the following command precedes the first `LOAD` command in the file:

```
LOAD TCPIP RIP=Yes FORWARD=No<
```

At bootup, the system must load the TCP/IP protocol stack before encountering a `BIND IP` command.

Continue the installation with the next section.

Editing MTU Size

All clients on the same logical subnet must use the same MTU (Maximum Transfer Unit) size. The driver allows communications at 1516 bytes, 4544 bytes, or 9234 bytes.

To edit the MTU size for a client, do the following:

1. Find the `LOAD` line in the `AUTOEXEC.NCF` file for the client you want to change.

For example, the line for the Client 1 on the first adapter should be similar to:

```
LOAD 5515SI CHANNEL=1 ELAN=engr \  
    FRAME=Ethernet_II NAME=ch1_sta12 \  
    SLOT=1
```

If the `MTU` variable does not appear in the command, as shown in the above example, the driver assumes a setting of 1516 bytes.

2. Add or modify the `MTU` variable with one of the following values:

MTU=1: representing 1516 bytes

MTU=4: representing 4544 bytes

MTU=9: representing 9234 bytes

The previous example set to 4544 bytes would be as follows:

```
LOAD 5515SI CHANNEL=1 ELAN=engr \  
    FRAME=Ethernet_II NAME=ch1_sta12 \  
    SLOT=1 MTU=4
```

For more information about these settings, see Table 5-1 on page 75.

3. If the `MTU` variable in the previous step is set to 4 or 9, the maximum packet size for the system must be set to accommodate the larger framing size. For more information, see *Editing Maximum Packet Size* on page 73.

Continue the installation with the next section.

Editing UNI Signalling

The ATM drivers are designed to operate with the UNI 3.0/3.1 signalling specification.

To edit the UNI setting for a client, do the following:

1. Find the `LOAD` line in the `AUTOEXEC.NCF` file for the client you want to change.

For example, the line for the second client on the first adapter should be similar to:

```
LOAD 5515SI CHANNEL=2 ELAN=sales \  
    FRAME=Ethernet_II NAME=ch2_stal2 \  
    SLOT=1
```

If the UNI variable does not appear in the command, as shown in the above example, the driver assumes a setting of UNI 3.0.

2. Add or modify the UNI variable with one of the following values:

UNI=3.0: representing UNI specification 3.0

UNI=3.1: representing UNI specification 3.1

The previous example set to UNI specification 3.1 would be as follows:

```
LOAD 5515SI CHANNEL=2 ELAN=sales \  
    FRAME=Ethernet_II NAME=ch2_stal2 \  
    SLOT=1 UNI=3.1
```

For more information about these settings, see Table 5-1 on page 75.

Continue the installation with the next section.

Changing a LEC to an IP over ATM Client

One LEC per adapter can be changed to an IP over ATM client.

The prerequisites for changing a LEC are:

- TCP/IP is installed on the machine
- The target LEC is configured to use the TCP/IP protocol

For more information on these items, see *Configuring Protocols and Parameters* on page 69.

To change a LEC to an IP over ATM client, do the following:

1. Find the set of `LOAD` and `BIND` commands in the `AUTOEXEC.NCF` file which represent the client you want to change to an IP over ATM client.

For example if you configured Channel 3(Client 3) for TCP/IP communications, you would look for a set of commands similar to:

```
LOAD 5515SI CHANNEL=3 ELAN=admin \
    FRAME=Ethernet_II NAME=ch3_stal2 \
    SLOT=1
```

```
BIND IP to ch3_stal2 ARP=Yes \
    ADDRESS=123.234.100.015 \
    MASK=255.255.255.0
```

2. To make this client an IP over ATM client, add the term **IPENABLE=Y** to the end of the `LOAD` line.

For example,

```
LOAD 5515SI CHANNEL=3 ELAN=admin \
    FRAME=Ethernet_II NAME=ch3_stal2 \
    SLOT=1 IPENABLE=Y
```

For more information about these settings, see Table 5-1 on page 75 and Table 5-3 on page 77.

3. Check and make sure the following command precedes the first `LOAD` command in the file:

```
LOAD TCPIP RIP=Yes FORWARD=No<
```

Continue the installation with the next section.

Configuring Multiple Adapters

The NetWare `install` utility does not provide for multiple adapter configurations. The driver commands must be installed manually for each additional adapter in the server. This is accomplished by adding a set of `LOAD` and `BIND` commands in the `AUTOEXEC.NCF` file for each client on each additional adapter. The easiest way to add these commands is to copy and paste a set of existing commands, then edit the parameters to support a different adapter.

To configure multiple adapters, do the following:

1. Find and copy a set of `LOAD` and `BIND` commands for an existing client which are similar to the commands you want for a client on the new adapter.
2. Paste the commands ahead or before the `load asig` command which was added to the file in a previous section.
3. Edit the parameters to support a different adapter.

For example, if you are installing an additional adapter in slot #2 with IPX for one client and TCP/IP for a second client, entries to the `AUTOEXEC.NCF` file would be similar to the following:

```
LOAD 5515SI CHANNEL=1 ELAN=engr2 \  
    FRAME=Ethernet_802.3 NAME=ch1_sta22 \  
    SLOT=2  
  
BIND IPX to ch1_sta22 NET=99A64B52  
  
LOAD 5515SI CHANNEL=2 ELAN=engr3 \  
    FRAME=Ethernet_II NAME=ch2_s22 \  
    SLOT=2  
  
BIND IP to ch2_s22 ARP=Yes \  
    ADDRESS=123.234.100.015 \  
    MASK=255.255.255.0
```

For more information about these commands, see *Formatting Commands* on page 75.

4. Continue the copy, paste, and edit of the `LOAD` and `BIND` commands until all needed clients on all adapters are properly configured.
5. Check and make sure the following command precedes the first `LOAD` command in the file:

```
LOAD TCPIP RIP=Yes FORWARD=No<
```

Continue the installation with the next section.

Configuring the Adapter to the Network

When the editing of the `AUTOEXEC.NCF` file is complete as described in the previous sections, do the following:

1. Save and exit the `AUTOEXEC.NCF` file.
2. Exit the NetWare `install` utility.
3. Reboot the server.
4. See *CellView Utility for NetWare Servers* on page 87 to configure the clients to the network
5. When complete, exit the CellView utility.

The installation of the driver for the PCI ATM adapter is complete.

Continue with the next section if you want to verify the installation.

Verifying the Installation

An application program does not have to be running in order to verify the driver is up and running. At bootup of the endstation, certain systems communications must take place between the client and the server (through the switch) in order for the client to log on to the network. Use the Statistics routines in the CellView utility to monitor this traffic as well as for checking a few other essential items. If you find an item in error, or you suspect something is wrong with your setup, see *Network Problems* on page 121.

To perform a quick check of the operating statistics for an adapter, do the following:

1. Start the CellView utility with the command:

```
load cellview
```

2. When the main CellView dialog appears, select an adapter in the list box; that is, if more than one adapter is installed in the machine.

3. Select **Statistics**.

The Signalling dialog appears for the selected adapter.

- The three text fields in the Signalling State box should have values similar to:

```
ILMI: Up  
QSAAL: Up  
Signalling: Init
```

- The three text fields in the State Detail box should have values similar to:

```
ILMI: Registered  
QSAAL: Ready  
Signalling: Ready
```

- There should be some traffic in the Signalling Statistics box for both ILMI Frames In and ILMI Frames Out.
4. Select **AAL5**.
 - All six text fields under SONET should read **Ok**.
 - There should be some traffic in the AAL5 Statistics fields.
 5. If at least one LEC on the adapter is enabled, select **LEC**.
 - a. Select an enabled LEC.
 - The LEC State field should read **Ready**.
 - b. Select **LEC (CCT)** for the client.
 - There should be some traffic in the Tx Packets and Rx Packets fields of the display boxes.
 - c. Repeat the above step for all enabled LECs.
 6. If the IP over ATM client is enabled, select **1577**.
 - The 1577 State field should read **Ready**.
 - There should be some traffic in the 1577 Statistics fields.
 7. If more than one adapter is installed in the machine, repeat step **2** through step **6** for each additional adapter.

When complete, exit the CellView utility.

Removing a Driver

To remove a driver from the `AUTOEXEC.NCF` file, do the following:

1. At the system prompt, enter the command:

Removing a Driver

load install

2. When the Installation Options dialog appears, select **NCF files options**, then select **Edit the autoexec.ncf** to open the file for editing.
3. Remove the `LOAD` and `BIND` commands for each channel of the adapter by deleting all lines similar to the following:

```
LOAD 5515SI CHANNEL=1 ELAN=engr2 \  
    FRAME=Ethernet_802.3 NAME=ch1_sl2 \  
    SLOT=2
```

```
BIND IPX to ch1_sl2 NET=99A64B52
```

If the driver(s) are not being reinstalled, then remove the commands:

```
load asig  
load cvconf
```

4. Save and exit the `AUTOEXEC.NCF` file.
5. Exit the NetWare `install` utility.
6. Reboot the server.



CAUTION

Do not attempt to reinstall the driver before rebooting the NetWare server.

The removal of the driver is complete.

CellView Utility for NetWare Servers

6

Overview

This utility is used to configure the ATM clients and services on file servers running Novell NetWare Server version 3.12, 4.10, or 4.11. All screens and dialogs are in text format and require input from the keyboard to navigate the utility. You do not have to reboot the server for the edits to take effect. Pressing the F10 key at any time sends your changes to the driver for immediate, dynamic update.

The driver takes advantage of the more recent evolutions in switch designs where SVCs and PVCs can be mixed throughout the network. For example, you can have multiple clients using SVC signalling, and at the same time have a dedicated PVC between a client and another end station on the network. CellView enables you to:

- Enable, disable, and configure up to four LECs and one IP over ATM client per adapter
- Set up PVC communications with other end stations
- Enable, disable, and configure up to eight LESs and one IP over ATM ARP server per adapter
- Enable, disable, and configure one LECS per adapter
- Display operating statistics for
 - SONET, signalling, and cell level activity
 - ATM Adaptation Layer 5 (AAL5) activity
 - LEC membership and activity
 - IP over ATM activity
 - LECS and LES activity

Configuration Requirements

The degree of configuration needed for the adapter(s) depends largely on whether the services are already installed on the network. For example, if the LECS, LESs and ARP server are running elsewhere in the network, you need to enable and configure only the local clients.

Configuration Requirements

Before you begin the configuration procedures described in this chapter, the following requirements must be met:

- At least one adapter is installed in the end station.
- The driver for your operating system is installed.
- The NetWare server has been rebooted after the driver installation.

If any of these tasks are not complete, please complete them now. Refer to the appropriate chapter(s) or addendum(s) for instructions.

ATM Address

During configuration, you will need to be familiar with the end station's unique ATM address, as shown in the ATM Address field in Figure 6-1.

ATM Address:	
47:00:00:00:00:dd:01:00:00:27:2a:84:00:00:00:77:86:da:61-00	
Network Prefix:	ESI/Selector:
47:00:00:00:00:dd:01:00:00:27:2a:84:00	00:00:77:86:da:61-00

Figure 6-1. ATM Address

The Network Prefix and ESI/Selector fields show the separate ATM address components.

The network prefix is the 13-byte link address of the adapter, as set by the ATM switch.

The ESI/Selector consists of a unique end station identifier (ESI) and a pointer (selector) with the following values:

- The ESI value is the 6-byte MAC address of the adapter (00:00:77:86:da:61 in the example).
- The Selector value is a 1-byte pointer to clients and services located in the end station (00 in the example).

The Selector value for the end station is always 00. The Selector values for the clients and services located in the end station are as follows:

Item Number	Range of Selector Values
LEC1 – LEC4	0x00–0x03
LES1 – LES8	0x20–0x27
BUS1 – BUS8	0x40–0x47

Starting CellView

To start the CellView utility, enter the command `load cellview`

The main CellView dialog appears as shown in the following figure.

Starting CellView

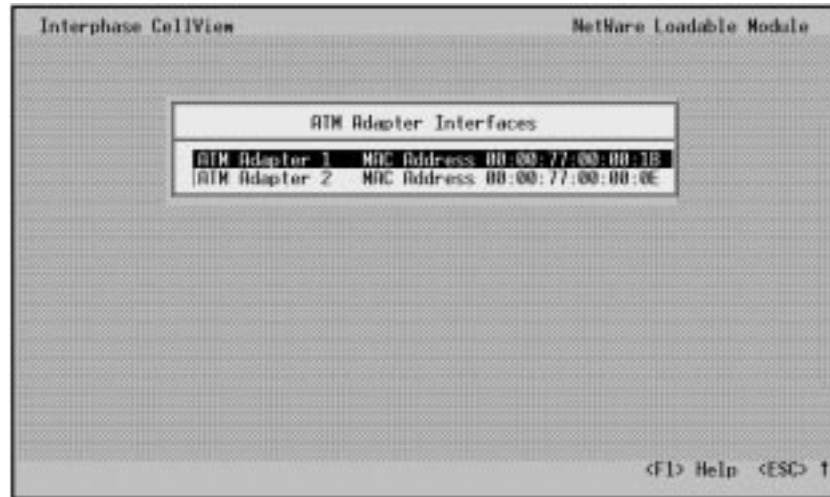
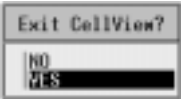

Figure 6-2. Main CellView Dialog

The main CellView dialog lists the adapter(s) installed in the NetWare server. The contents of subsequent Setup and Statistics dialogs apply to the adapter that is highlighted in the ATM Adapter Interfaces box. The main CellView dialog has three keyboard options:

Press this key . . .	To do this . . .
F1	Activate the Help dialog.
ESC	Exit the CellView utility.  A dialog appears, as shown at left, for selecting YES to exit or NO to return to the CellView utility.
Enter	Select an adapter. The contents of each subsequent dialog are tied to the adapter being highlighted in the ATM Adapter Interfaces box.

The first dialog to appear when pressing the Enter key at the main CellView menu is the ATM Adapter dialog.

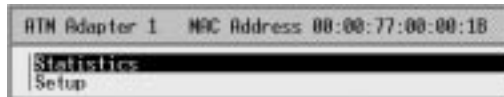

Figure 6-3. ATM Adapter Selections

The ATM Adapter dialog provides the following selections:

Select...	To do this...
Statistics	To display the status of: <ul style="list-style-type: none"> • Signalling • AAL5 • LECs • LESs • LECS • IP over ATM (1577) client and ARP server
Setup	To configure: <ul style="list-style-type: none"> • LECs (4 maximum per adapter) • LEC PVC connections • LESs (8 maximum on same adapter as LECS) • LECS (on same adapter as the LESs) • IP over ATM (1577) client and ARP server • IP over ATM (1577) PVC connections

Setup

Use the CellView Setup dialogs to configure your adapter(s) to the ATM network. You can configure up to four LECs and one IP over ATM client per adapter. The number of clients per

Setup

adapter is specified during driver installation. You can also configure one LECS and up to eight LESs per adapter for the ATM network.

Common keyboard commands for the dialogs are as follows:

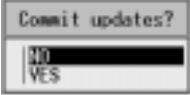
Press this key . . .	To do this . . .
F1	Activate the Help dialog.
F2	Change the current dialog to edit mode.
F10	Send your changes to the driver for immediate, dynamic update.
TAB	Move the cursor to the next edit field in the dialog if the edit mode (F2) is active; otherwise, move the cursor to the next dialog.
<numeric keys 1-4>	Select clients 1 through 4 when displaying the LEC dialogs. The option appears at the bottom of the dialog when there is more than one client initialized for the adapter.
<numeric keys 1-8>	Select servers 1 through 8 when displaying the LES dialogs.
ESC	Exit the dialog.  When exiting a Setup dialog that has been edited or changed, a prompt appears as shown. If you wish to save the updates, select YES and the changes are sent to the driver for immediate action. You do not have to reboot the machine for the changes to take effect. Otherwise, select NO and another dialog appears, advising the updates are being discarded.

No particular order is required for configuring clients and services. However, **if you will be enabling the LECS and the LESSs**, configure these first before configuring the clients.

Before starting configuration, make sure preliminary requirements are met, as described in *Configuration Requirements* on page 88. Then start CellView, as described in *Starting CellView* on page 89.

After starting CellView, configure the clients and servers for each adapter in the end station as described in the following overview of Setup tasks:

1. On the main CellView dialog, highlight the adapter you are configuring, and press **Enter**.
2. Highlight **Setup** and press **Enter** to make dialogs available for setting up the clients and servers.
3. **If the LECS and the LES(s) will be on this machine**, use the LECS and LES dialogs to configure these servers.
4. On the LEC dialog(s), configure the LECs specified for the adapter during driver installation.
5. On the 1577 dialogs, configure the IP over ATM client and ARP server, if specified for the adapter during driver installation.

You can make the changes take effect at any time by pressing the F10 key.

Setup

The following table identifies where to find information about CellView Setup tasks:

For information about...	See page...
Setting Up LAN Emulation Clients	94
LEC PVC Settings	99
Setting up IP over ATM Client and Server	102
IP over ATM PVC Settings	105
Setting Up a LAN Emulation Configuration Server	108
Setting Up a LAN Emulation Server	110

Setting Up LAN Emulation Clients

The driver allows up to four LECs per adapter to be enabled at a time. A client can be enabled only if it was initialized during installation of the driver. You must enable and fully configure at least one LEC or an IP over ATM client before running applications on the network. Other clients are optional, and can be enabled at any time.

CellView provides a separate dialog for each LEC setup. The dialog contains all the parameters to establish communications with an LECS at bootup, or can be set to contact an LES directly. The clients can be enabled for SVC and PVC communications or set to communicate with PVC only. The procedures for setting up the PVC table is contained in a separate dialog.

To set up a LEC:

1. On the main CellView dialog, highlight the adapter you want to configure and press **Enter**.
2. Select **Setup**.

The LEC dialog appears for LEC 1.

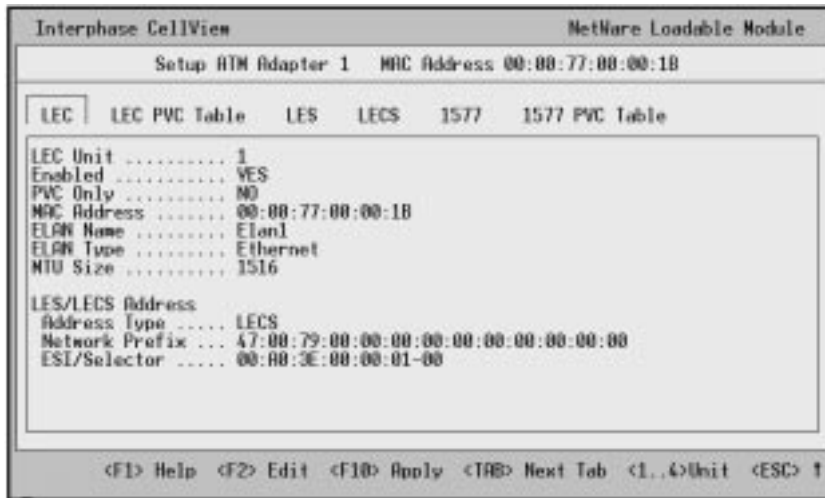

Figure 6-4. CellView LEC Setup

3. If more than one LEC is initialized for the adapter and you want to edit a client other than LEC 1, press numeric key **2**, **3**, or **4** to select LEC 2, LEC 3 or LEC 4.
4. Press **F2** to edit the LEC dialog.
5. Enter information in the LEC dialog fields to configure the following:
 - LEC settings and LECS/LES ATM address settings
 - LEC PVC settings

The following topics provide information about configuring these settings.

Setup

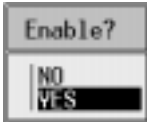
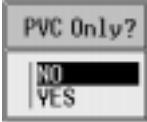

LEC and LECS/LES ATM Address Settings

To configure LEC settings and LECS/LES ATM address settings, provide information in the LEC dialog fields as follows:

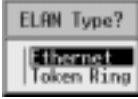
Use this field...	To do this...
Enabled	Enable the LEC.  When set to YES , the client is enabled. If using PVCs only, the client must be enabled in order for the driver to recognize the client.
PVC Only	 When set to YES , all SVC activity for the client is disabled. You must set up the table as described in <i>LEC PVC Settings</i> on page 99.
MAC Address	(Display Only) Contains the MAC address of the LEC. LEC 1 is assigned the base address for the adapter. The remaining LECs use an increment of the base address for their MAC address. If the LEC is enabled as Token Ring, the MAC Address is displayed in non-canonical format.

Use this field...	To do this...
ELAN Name	<p>Identify the network name of the emulated LAN you want the client to join.</p> <p>Some configuration servers require a name while others do not. The Interphase LECS and LESs require a name only in the following cases:</p> <ul style="list-style-type: none">• The Strict ELAN Name field is enabled on the LES dialog.• You need to differentiate between two or more LESs with the same MTU size and ELAN type. <p>For exact requirements, see your server documentation. For information about setting up Interphase servers, see <i>Setting Up a LAN Emulation Configuration Server</i> on page 108 and <i>Setting Up a LAN Emulation Server</i> on page 110.</p>
ELAN Type	 Select the ELAN type. All nodes on the same logical subnet must use the same frame type.

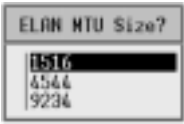
Setup

Use this field...	To do this...
<p>MTU Size</p>	 <p>Select the requested ELAN MTU size. The client uses this entry when making a request to join a LES. The MTU returned to the client is equal to or less than the requested value.</p> <p>Recommended settings are:</p> <ul style="list-style-type: none"> • ELAN with Ethernet edge device: 1516 • ELAN with Token Ring edge device: 4544 • ELAN with ATM end stations only: 9234 <p>All nodes on the same logical subnet must use the same MTU size.</p> <p>Important Note: At installation of the driver, the MTU size has a default value of 1516. Do not select another value for the ELAN MTU Size unless the MTU value in the client's <code>LOAD</code> line in the <code>AUTOEXEC.NCF</code> file is changed accordingly. The setting in CellView and the setting in the <code>AUTOEXEC.NCF</code> file must be the same value. See <i>Editing MTU Size</i> on page 78.</p> <p>Also, if you use a MTU size of 4544 or 9234 for any client, the maximum packet size for the system must be set to accommodate the larger MTU size. See <i>Editing Maximum Packet Size</i> on page 73.</p>
<p>LECS/LES ATM Address</p>	 <p>Select the mode of contact at bootup. The LES setting uses the 20-byte address in the ATM address fields to contact a LES directly.</p> <p>The LECS setting contacts the LECS with the 20-byte ATM address in the Network Prefix and ESI/Selector fields. (The default address is the ATM Forum's well-known address.)</p>

LEC PVC Settings

Use the LEC PVC Table, located in a separate dialog, to set permanent links between a client and other end stations on the network. Changes to the table take effect immediately and do not require a reboot of the computer.

With the LEC enabled, do the following:

1. Exit the LEC dialog and tab to **LEC PVC Table**.
2. If more than one LEC is initialized for the adapter and you want to edit a table other than for LEC 1, press numeric key **2**, **3**, or **4** to select the table for LEC 2, LEC 3 or LEC 4.
3. Press **F2**.

The PVC table for the client appears, as shown in Figure 6-5. In this example, the table for LEC 1 is selected.

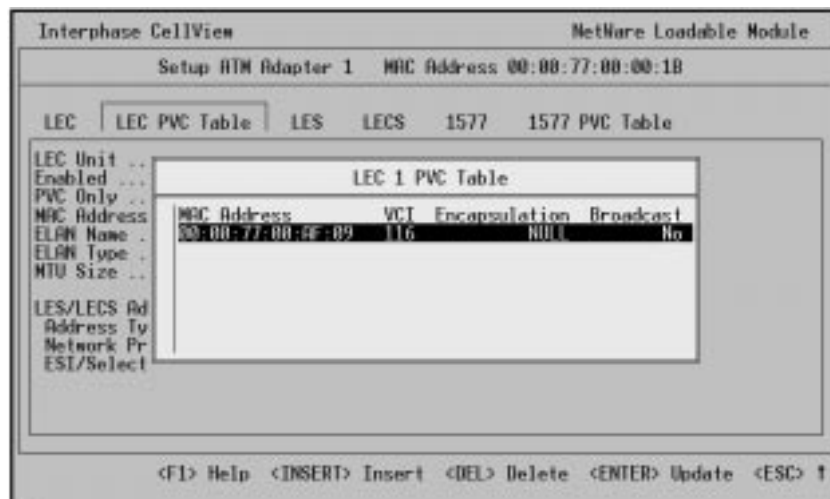

Figure 6-5. LEC PVC Table

Setup

A 6-byte MAC address and a VCI number are associated with each PVC. Packets from the upper layers whose destination MAC address matches an address in the PVC table are transmitted on that PVC.

The corresponding LEC must be enabled in order to use PVC communications. If the PVC Only parameter in the client's dialog is set to YES, make sure the client's MTU Size is set to the appropriate value for the PVC communications.

In addition to providing setup information in the LEC PVC Table, you must also consider the following when configuring PVCs:

- All PVCs must be configured in the adapters and the switch(es) manually.
- The MAC address of the target station must be mapped to a VCI in the local host.
- The MAC address of the local client must be mapped to a VCI in the target station.

You can use the keyboard options in the PVC table to add, modify, or delete PVC table entries, as described in the following topics.

Adding or Modifying LEC PVC Table Entries

To add or modify PVC table entries for the LEC:

1. Press **Insert** to add a PVC setting; or highlight the appropriate entry and press **Enter** to revise a PVC setting.

The following dialog appears:

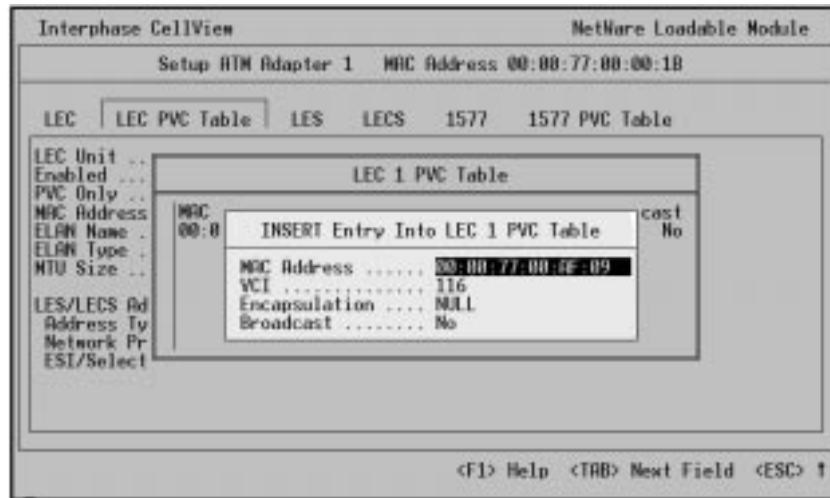
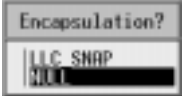
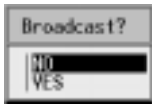

Figure 6-6. PVC Settings for LECs

2. Provide information in the PVC Settings dialog fields as follows:

Use this field...	To do this...
MAC Address	Enter the 6-byte address of the target station. Use the natural format for the ELAN. For example, for a Token Ring ELAN, use non-canonical format.
VCI	Enter the VCI number the LEC uses to communicate with the target station. The range is 32–1023. (The corresponding VPI cannot be edited and is fixed at a value of zero.)
Encapsulation	 Select the encapsulation method (LLC_Snap or Null). The host and target must use the same encapsulation method.

Setup

Use this field...	To do this...
Broadcast	 <p>When set to YES, enables the entry as a Broadcast PVC.</p> <p>If enabled, all broadcast/multicast packets from the upper layers are transmitted on this PVC. A maximum of 16 Broadcast PVCs can be enabled on each LEC.</p>

Deleting LEC PVC Table Entries

To delete a PVC table entry, highlight the entry and press **Delete**.

Setting up IP over ATM Client and Server

The IP over ATM client conforms to the RFC-1577 specification using Classical IP over ATM where no multicast or broadcast services are available.

Using the 1577 dialog, you can enable the Classical IP over ATM client and enable the host adapter as the Address Resolution Protocol (ARP) server for the network. The client can be set for SVC and PVC communications or set to communicate with PVC only. The procedures for setting up the PVC table is contained in a separate dialog.

To set up an IP over ATM client/server configuration:

1. On the main CellView dialog, highlight the adapter you want to configure and press **Enter**.
2. Select **Setup**, and then tab to **1577** to display the IP over ATM dialog.
3. Press **F2** to edit.

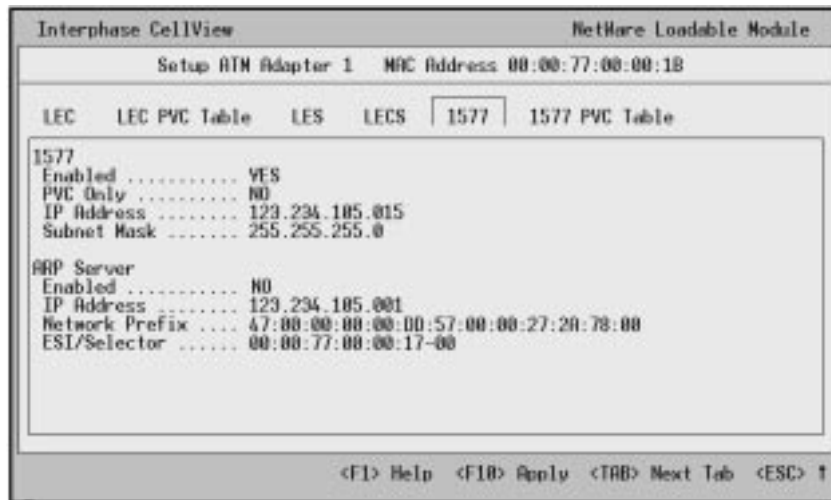
**Figure 6-7. CellView IP over ATM Setup**

4. Enter information in the 1577 dialog fields to configure the following:
 - IP over ATM client and ARP server settings
 - IP over ATM PVC settings

The following topics provide information about configuring these settings.

Setup

IP over ATM Client and ARP Server Settings

To configure IP over ATM client and ARP server settings, provide information in 1577 dialog fields, as follows:

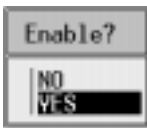
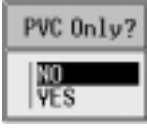
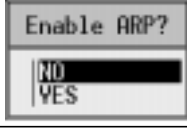
Use this field...	To do this...
Enabled	 <p>When set to YES, enables the Classical IP over ATM client.</p>
PVC Only	 <p>When set to YES, all SVC activity for the client is disabled. You must set up the table as described in <i>IP over ATM PVC Settings</i> on page 105.</p>
IP Address	Verify or enter the client's IP address.
Subnet Mask	Verify or enter the client's subnet mask identifier.
ARP Server: Enabled	 <p>When set to YES, enables the host adapter as the ARP server for your IP over ATM network.</p>
ARP Server: IP Address	If the host adapter is not the ARP server, enter the IP address of the ARP server located elsewhere in the network.
ARP Server: Network Prefix and ESI/Selector	<p>If the host adapter is not the ARP server, enter the ARP server's ATM address, which consists of the Network Prefix and ESI/Selector. (For details about the address structure, see <i>ATM Address</i> on page 88.)</p> <p>The IP over ATM driver must know the ATM address of the ARP server. When the system is powered up, it calls the ARP server with this ATM address.</p>

IP over ATM PVC Settings

Use the 1577 PVC Table, located in a separate dialog, to set permanent links between the local IP over ATM client and other end stations on the network. Changes to the table take effect immediately and do not require a reboot of the computer.

With the IP over ATM client enabled, do the following:

1. Exit the 1577 dialog and tab to **1577 PVC Table**.
2. Press **F2**.

The 1577 PVC Table dialog appears.



Figure 6-8. PVC Table for IP over ATM

An IP address and VCI number are associated with each PVC. Packets from the upper layers whose destination address matches an address in the PVC table are transmitted on that PVC.

Setup

In addition to providing setup information in the PVC Table, you must also consider the following when configuring PVCs for the IP over ATM client:

- All PVCs must be configured in the adapters and the switch(es) manually.
- The IP address of the target station must be mapped to a VCI in the local host.
- The IP address of the local client must be mapped to a VCI in the target station.

You can use the keyboard options in the PVC table to add, modify, or delete PVC table entries, as described in the following topics.

Adding/Modifying IP over ATM PVC Table Entries

To add or modify PVC table entries for an IP over ATM client:

1. Press **Insert** to add a PVC setting; or highlight the appropriate entry and press **Enter** to revise a PVC setting.

A dialog appears, as shown in Figure 6-9 on page 107.



Figure 6-9. PVC Settings for IP over ATM

2. Provide information in the 1577 PVC Table fields as follows:

Use this field...	To do this...
IP Address	Enter the IP address of the target station.
VCI	Identify the VCI number the IP over ATM client uses to communicate with the target. The range is 32–1023. (The corresponding VPI cannot be edited and is fixed at a value of zero.)
Encapsulation	 Select the encapsulation method (LLC_Snap or Null). The host and target must use the same encapsulation method.

Deleting IP over ATM PVC Table Entries

To delete a PVC table entry, highlight the entry, and press **Delete**.

Setup

Setting Up a LAN Emulation Configuration Server

To communicate on an ATM network, a LEC must join an emulated LAN (ELAN). The ELAN consists of a group of end stations which communicate among themselves with the same MTU size, the same frame format, and the same broadcast/multicast services. The LAN Emulation Server (LES) is the central server for the ELAN. The LAN Emulation Configuration Server (LECS) manages which LEC joins which LES.

The LECS must reside on the same ATM adapter with the LESs it serves; it cannot communicate with LESs across the network. You must enable the LECS and associated LESs before configuring the LECs which join LESs.

The LECS provides a central point of contact on the network for each LEC at bootup. The client sends the LECS a request for the type of ELAN it wants to join. The LECS responds with the current ATM address and the configuration parameters of the LES that serves the requested ELAN.

To set up the LECS:

1. On the main CellView dialog, highlight the adapter you want to configure and press **Enter**.
2. Select **Setup**, then tab to **LECS** to display the LECS dialog.
3. Press **F2** to edit.

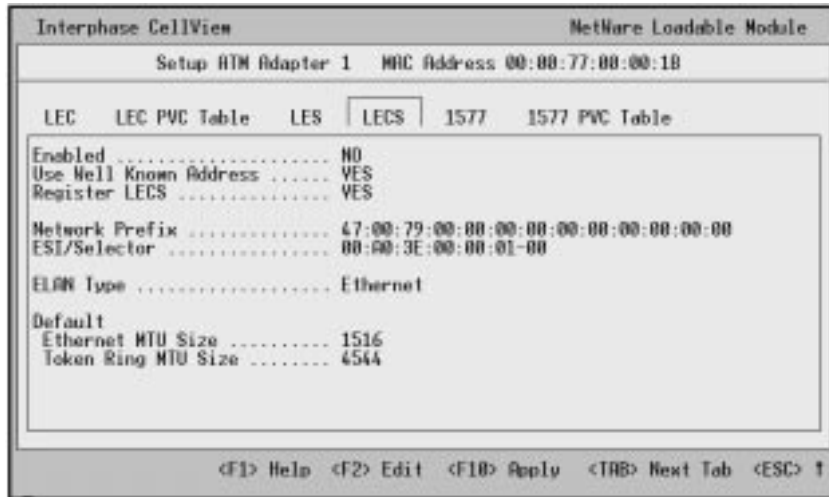
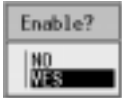
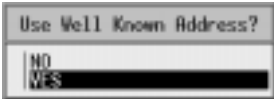
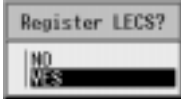
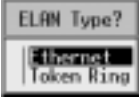

Figure 6-10. CellView LECS Setup

4. Provide information in the LECS dialog fields as follows:

Use this field...	To do this...
Enabled	 Enable the LECS and all permanent mappings of LECs to specific LESs.
Use Well Known Address	 When set to YES , enables the loading of the ATM Forum's well-known address to the Network Prefix and ESI/Selector fields. When enabled, these address fields cannot be edited.
Register LECS	 Select YES to register the ATM address in the Network Prefix and ESI/Selector fields with the switch at bootup.

Setup

Use this field...	To do this...
ELAN Type	 <p>Select a default ELAN type (Ethernet or Token Ring) to assign to an LEC if the LEC's configuration request omits the ELAN type.</p> <p>If the MTU size is omitted in the client's request, the corresponding value in the Default Ethernet MTU Size field or Default Token Ring MTU Size field is returned to the client.</p>
Default: Ethernet MTU Sizes	(Display Only) For Ethernet, an MTU size of 1516 is assigned to an LEC if the LEC's configuration request omits the MTU size.
Default: Token Ring MTU Size	(Display Only) For Token Ring, an MTU size of 4544 is assigned to an LEC if the LEC's configuration request omits the MTU size.

Setting Up a LAN Emulation Server

To communicate on an ATM network, a LEC must join an emulated LAN (ELAN). The ELAN consists of a group of end stations which communicate among themselves with the same MTU size, the same frame format, and the same broadcast/multicast services. The LAN Emulation Server (LES) is the central server for the ELAN. It provides address registration, address resolution, and broadcast services for all ELAN members. The LAN Emulation Configuration Server (LECS) manages which LEC joins which LES.

The driver allows up to eight LESs to be enabled per adapter at one time (therefore allowing adapter support for up to eight ELANs). LESs must reside on the same ATM adapter with the LECS that serves them; they cannot communicate with the LECS across the network. You must enable a LES and its associated LECS before configuring LECs to join the LES.

When a LEC joins a LES, the MAC-ATM relationship of the client is registered with the LES. The LES maintains a running account of these addresses to resolve queries from ELAN members. The connection between the LES and each LEC is a permanent, open connection as long as the client is running.

The LES maintains a table of client information which it uses to provide address resolution services to the ELAN. When an end station is disconnected or turned off, the LES removes client(s) from the table automatically. Therefore, relocating an end station is a matter of physically moving the hardware and connecting it to the same or another ATM switch. At bootup, the client(s) rejoin the previous LES with a new ATM address.

CellView provides a separate dialog for each LES-ELAN setup. Changes to the LES dialogs are dynamic, and take effect when you exit the dialog or press the F10 key.

To set up a LES:

1. On the main CellView dialog, highlight the adapter you want to configure and press **Enter**.
2. Select **Setup**, and then tab to **LES**.
3. If you wish to edit a LES other than LES 1, press numeric key **2–8** to select the dialogs for LES 2 through LES 8.

Setup

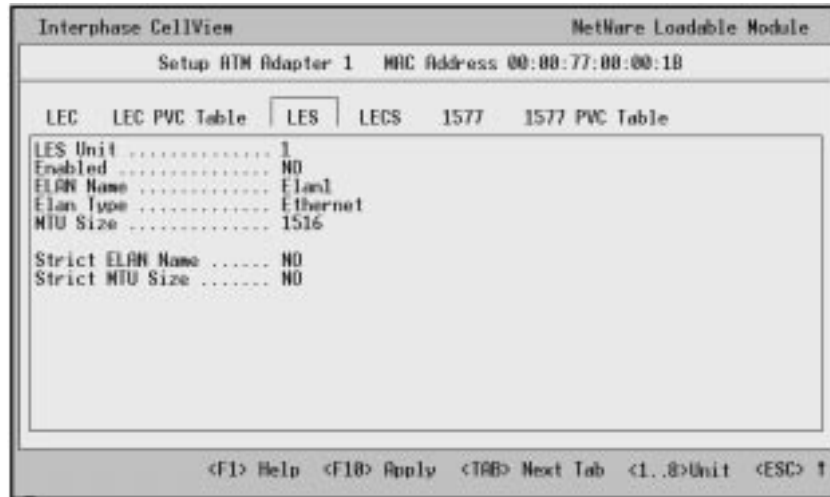
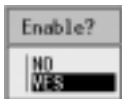
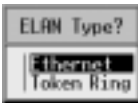

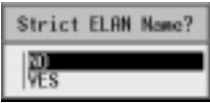
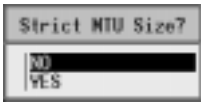

Figure 6-11. CellView LES Setup

4. Press **F2** to edit.
5. Enter information in the LES dialog fields.

To configure LES settings, provide information in the LES dialog fields, as follows:

Use this field...	To do this...
Enabled	 When set to YES , enables the LES.
ELAN Name	Enter the name of the ELAN for which the LES provides services (not required for a LEC to join the group). If the Strict ELAN Name field (on this dialog) is set to YES, the ELAN name in the LEC request must exactly match this name (case sensitive). Otherwise, the server prevents the LEC from joining the group.

Use this field...	To do this...
ELAN Type	 <p>Select the ELAN type (Ethernet or Token Ring) to use for all communications between end stations.</p> <p>If the ELAN includes an edge device to a legacy LAN, the ELAN type must be set to interface with that edge device.</p>
MTU Size	 <p>Select the MTU size for the ELAN for which the LES provides services.</p> <p>Recommended options are:</p> <ul style="list-style-type: none"> • ELAN with Ethernet edge device: 1516 • ELAN with Token Ring edge device: 4544 • ELAN with ATM end stations only: 9234 <p>If the Strict MTU Size field (on this dialog) is set to YES, the request from the LEC must exactly match the ELAN MTU Size. Otherwise, the server prevents the LEC from joining the group.</p>
Strict: ELAN Name	 <p>When set to YES, specifies the ELAN Name in the LEC's request must exactly match (case sensitive) the entry in the ELAN Name text field on this dialog.</p>
Strict: MTU Size	 <p>When set to YES, specifies the ELAN MTU Size in the LEC's request must exactly match the entry in the ELAN MTU Size field on this dialog.</p>

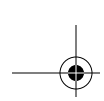

Statistics

Statistics

The dialogs in the Statistics group are provided to assist you and Interphase personnel with troubleshooting ATM network problems. Limited procedures for using the dialogs are included in the troubleshooting sections of this Users Guide. CellView can gather operating statistics for local Interphase clients and servers only. It cannot gather statistics from switches or from other end stations.

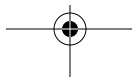

Troubleshooting

7

This chapter provides possible solutions for common problems encountered while installing and operating the ATM adapter. Before proceeding with the troubleshooting, make sure you have carefully followed the steps for installing the hardware and the software, and you have rebooted the system. Also, check the systems log for your operating system to see what kind of errors, if any, are being recorded. This may provide some insight to the problem.

If the information in this chapter does not resolve the problem, contact Interphase Customer Support at one of the locations listed in the front of this users guide.

Verifying Driver Installation

An application program does not have to be running in order to verify the driver is up and running. At bootup of the endstation, certain systems communications must take place between the client and the server (through the switch) in order for the client to log on to the network. Use the Statistics routines in the Interphase CellView utility to monitor this traffic as well as for checking a few other essential items. If you find an item in error, or you suspect something is wrong with your setup, see *Network Problems* on page 121.

To perform a quick check of the operating statistics for an adapter, do the following:

1. Start the CellView utility.

If needed, see *Starting CellView* on page 32 for startup instructions.

Verifying Driver Installation

2. When the main CellView dialog appears, select an adapter in the list; that is, if more than one adapter is installed in the machine.

3. Select **Stats**.

The Signalling dialog appears for the selected adapter.

- All three graphical LEDs in the Signalling State box should be green.
- The three text fields in the State Detail box should read similar to:

ILMI: ILMI Registered

QSAAL: Data transfer ready

Signalling: Signalling ready

- There should be some traffic in the Signalling Statistics box for both Frames In and Frames Out.

4. Select the **AAL5** tab.

- All six graphical LEDs in the SONET box should be green.
- There should be some traffic in the AAL5 Statistics box.

5. If at least one LEC on the adapter is enabled, select the **LEC** tab, then do the following:

a. Select the tab for an enabled LEC.

- The LEC graphical LED should be green.
- There should be some traffic in the Tx Packets and Rx Packets fields of the display boxes.

b. Repeat the above step for all enabled LECs.

6. If the IP over ATM client is enabled, select the **1577** tab.

- The 1577 graphical LED should be green.

- There should be some traffic in the **1577** Statistics fields.

7. If more than one adapter is installed in the machine, repeat step **2** through step **6** for each additional adapter.

When complete, exit the CellView utility.

LED Diagnostics

The adapter has two LEDs, a green Link LED and a yellow Status LED with functions as shown in the following table.

LED	State	Function
Link	Off	The board is not receiving a signal from a switch or remote system.
Link	Solid Green	The board is receiving a signal from a switch or remote system.
Status	Off	The board does not have power.
Status	Solid Yellow	The board has power.
Status	Flashing Yellow	The driver is loaded.

The Link LED indicates the condition of the physical link between the adapter and the ATM switch. When the green LED is lit, light or electrical current is flowing between the two sets of hardware; however, there may or may not be any data flowing through the cable.

The Status LED serves two functions. When the machine is turned on, the LED glows a solid yellow indicating the adapter has power, then begins blinking when the software driver is loaded.

LED Diagnostics

Problem	Possible Solution
Link LED not lit	<p>There is failure in the hardware which is preventing the adapter from completing a physical link with the switch.</p> <ol style="list-style-type: none"> 1. Check the switch. It must be up and running in order for the adapter to make a link. 2. Unplug and reinstall the connectors. 3. If this does not work, try a known, good cable. 4. Check the transmit and receive wiring to see if they are reversed. For fiber see Figure 2-2 on page 11. For UTP connections, see <i>UTP Cabling</i> on page 129. 5. If a known, good cable is installed, then try another adapter in the expansion slot. If the green LED does not illuminate, the problem is most likely at the switch. Confirm this by configuring the cable to another port on the switch.
Status LED not lit	<p>Power is not getting to the adapter.</p> <ol style="list-style-type: none"> 1. Do a power reset of the computer by turning the power off and then on again. 2. Make sure the adapter is seated correctly in the expansion slot. Check for a bent pin or crack in the connector. 3. Try another expansion slot. 4. Try another adapter which is known to operate correctly.
Status LED lit, but not flashing	<p>The driver is not installed, or the driver is not installed correctly.</p> <ol style="list-style-type: none"> 1. Check the event log for your operating system to see if any errors were recorded during bootup which pertain to the ATM driver. This may provide some insight to the problem. 2. Install or reinstall the driver.

Bootup Problems

These type of problems are usually hardware related. The board is located in the wrong slot, the bus address is incorrect or in conflict with another device, and so forth. If the machine worked properly before the adapter was installed, then the problem is most likely with the adapter or with the hardware that was removed and replaced during installation of the adapter.

Problem	Possible Solution
Computer does not boot up	<ol style="list-style-type: none">1. Check to see if the adapter is properly seated in the expansion slot. Reseat the adapter and restart the machine.2. Try a different expansion slot.3. Remove the adapter and reboot the system.4. If the system returns to a normal state, try a different interrupt setting or reinstall the configuration utility (if applicable). Change one setting at a time and record the settings in order to keep track of your changes. It is helpful to temporarily remove non-essential hardware in your computer to reduce the number of conflicts.5. Install an adapter that is known to work correctly. If the system boots up, the adapter in question is probably defective.

Bootup Problems

Problem	Possible Solution
Host adapter not found	<p>The operating system cannot find or does not recognize the adapter.</p> <ol style="list-style-type: none"><li data-bbox="643 575 1203 730">1. If this is your first bootup since installing the adapter, the configuration registers may not match what the operating system expects. Instead of rebooting the system, turn the power off and then on again to reset all components to an initial state.<li data-bbox="643 743 1203 867">2. The adapter is installed in the wrong slot. Make sure the adapter is in the slot for which the driver is configured. See your hardware manuals for the location of the proper expansion slots.<li data-bbox="643 879 1203 940">3. Make sure the adapter is seated correctly in the slot.<li data-bbox="643 953 1203 982">4. Try another expansion slot, if available.<li data-bbox="643 995 1203 1056">5. Try another adapter which is known to operate correctly.<li data-bbox="643 1068 1203 1192">6. Check the event log for your operating system to see if any errors were recorded during bootup which pertain to the ATM adapter or driver. This may provide some insight to the problem.

Network Problems

The procedures in this section assume the host workstation is up and running, the driver is loaded (yellow LED is blinking), and the adapter has formed a physical link (green LED is lit) with the switch. If needed, see *LED Diagnostics* on page 117 and the previous section, *Bootup Problems*.

Most of the problems discussed in this section concern getting the clients up and running, and logged on to the network. In all cases, check the event log for your operating system to see if the clients are being rejected by the LECS or the LES. It does not make any difference if the servers are located in the same endstation as the clients. In order for the client to have any form of communication with a server:

- The switch must be configured correctly
- Signalling must be up and running
- The adapter must be assigned a network prefix
- At least one client must be enabled
- At least one LES must be present on the network

The debug options in the CellView utility (see *Producing Debugging Messages* on page 63) are an excellent tool for troubleshooting the adapter and network related problems. Messages are logged from various modules to assist in isolating the problem. Be sure to disable the options when debugging is complete.

Network Problems

Problem	Possible Solution
Driver loads at bootup, but network clients are not connecting	<ol style="list-style-type: none">1. Use the CellView utility to check the state of signalling.<ol style="list-style-type: none">a. Select Stats from the main dialog.b. If the graphical LEDs for Signalling in the Statistics dialog are green then signalling is up and running. See the next Problem item.c. If the graphical LEDs are red, exit to the main dialog and select Setup.d. Make sure the setting in the UNI Revision field is set to coincide with the UNI setting in your switch.2. Use the CellView utility to check the hardware.<ol style="list-style-type: none">a. Select Stats from the main dialog.b. Select the AAL5 tab.c. If one or more of the graphical LEDs in the SONET box is red, there is a failure somewhere in the cable or connectors.3. Use the CellView utility to track communications between the adapter and the ATM switch.<ol style="list-style-type: none">a. Select Global from the main dialog.b. Select Debugging.c. Enable Signalling.d. Enable ILMI.e. Exit CellView and reboot the machine. <p>All communications are now being tracked between the adapter and the signalling daemon in the switch, as well as the protocols used to monitor all the other traffic. Check the messages in the event viewer or the systems log of your operating system. Be sure to disable the options in CellView when debugging is complete.</p>

Problem	Possible Solution
Signalling is running, but network clients are not connecting	Check the Network Prefix for the adapter. <ol style="list-style-type: none">1. From the main dialog select Stats. There must be a 13-byte address in the Network Prefix field. If not, the switch is configured incorrectly or the signalling setup for the adapter is in error.2. Exit to the main dialog and select Setup.3. Make sure the settings for the Enable Address Registration, the ILMI Port Change Detection and the Register Nonstandard Prefixes coincide with the capabilities of your LAN Emulation services. If automatic address assignment is not supported by the switch, the 13-byte address must be entered manually in the Network Prefix field.
Signalling and Address Registration are working, but network clients are not connecting	Check the settings for the client. <ol style="list-style-type: none">1. From the main dialog select Setup/LEC/LEC#.2. Make sure the LECS/LES parameters are specified correctly. These concern settings and parameters which must coincide with the capabilities of your switch.3. The MTU size must be equal to or greater than the setting for an LES. For example if only one LES is enabled with an MTU of 9K and the client attempts to join with an MTU of 1516, the client will be rejected.4. Check the other settings in the dialog and make sure they coincide with at least one of the enabled LESs.

Network Problems

Problem	Possible Solution
A network application no longer works	<ol style="list-style-type: none">1. If the application program worked prior to the installation of the adapter, there is probably a hardware conflict. Some programs which access the hardware can cause a conflict at some point. This typically happens with hardware such as printers and modems.2. Use the Interphase CellView utility to track the API (Application Program Interface).<ol style="list-style-type: none">a. Select Global from the main dialog.b. Select Debugging.c. Enable API.The lower level functions of the API are now being tracked. These are the routines used by the application software to manage or obtain system resources. Check the messages in the event viewer or the systems log of your operating system. If no messages are being recorded, reboot the machine, run the application again, then check the message log. Be sure to disable the option in CellView when debugging is complete.

Specifications

A

5515/5525/5575 Specifications

Item	Specification
Memory	5515/5575: 128K, 512K, or 1M buffer 1K serial EEPROM Optional Expansion ROM 5515/5575: 128K, 256K Control SRAM 5525: 128K Control SRAM
Host Bus Interface	PCI Local Bus Revision 2.1 32-bit 0 wait state Master 132 MBps burst DMA rate 32-bit Slave 5525/5575: 128 byte burst 5515: 64 byte burst 5525/5575: 256 byte FIFOs 5515: 128 byte FIFOs
Network Interface	5515/5575: 155 Mbps SONET OC-3c fiber 5515/5575: 155 Mbps SDH STM-1 fiber 5515/5575: 155 Mbps SONET UTP 5525: 25.6 Mbps AF-PHY-0040.00 UTP
Standards Compliance IEEE ATM Layer ATM Adaptation Layer	1496 CCITT I.361, ANSI T1S1/92-002R3 AAL 5
Diagnostics	LEDs: - Green "live incoming link" - Yellow "status"
PCI Slave	Memory and Configuration cycles Write posting

Operating Environment

Item	Specification
PCI Master	Zero wait states Memory cycles only Burst size selections: 128, 64, 32, 16, 8, 4 (Tx) 128, 64, 48, 32, 16, 8, 4 (Rx, On-board) 48, 32, 16, 8, 4 (Rx, CELL-FIFO) Memory Read Line support Memory Read Multiple support Memory Write and Invalidate
Operating Power	5515: 5.7W (1.14A @ 5V) 5525: 4.8W (.96A @ 5V) 5575: 5.75W (1.15A @ 5V)
Interrupts	Interrupt Pin: INTA#
Mechanical	5515: Length: 167.64 mm; Height: 106.68 mm 5525: Length: 167.64 mm; Height: 101.52 mm 5575: Length: 167.64 mm; Height: 93.345 mm

Operating Environment

Temperature	0–55° C / 32–131° F
Relative humidity	10–95% noncondensing
Altitude	0–15,000 feet

Storage Environment

This section assumes the adapter is stored in its original anti-static bag and box.

Temperature	-40–85° C / -42–185° F
Relative humidity	10–95% noncondensing
Altitude	0–50,000 feet

Network Connections

5515:		
	SC Duplex (155 Mbps)	Single Mode Fiber (8.25/125) Maximum cable length: 15 km Minimum cable length: 3 m
	SC Duplex (155 Mbps)	Multimode Fiber (62.5/125) Maximum cable length: 2 km Minimum cable length: 3 m
	RJ-45(155 Mbps)	Category 5 UTP Copper Maximum cable length: 100 m
5525:		
	RJ-45 (25.6 Mbps)	Category 3, 4 or 5 UTP Copper Maximum cable length: 100 m
5575:		
	SC Duplex (155 Mbps)	Multimode Fiber (62.5/125) Maximum cable length: 2 km Minimum cable length: 3 m
	RJ-45 (155 Mbps)	Category 5 UTP Copper Maximum cable length: 100 m

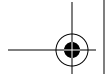

Network Connections

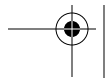

UTP Cabling

B

Straight-through Cable

To connect a PCI ATM adapter to an ATM switch, use a straight-through cable.

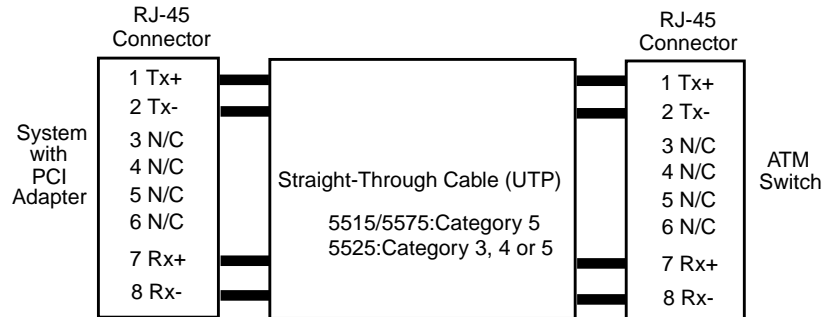

Crossover Cable

To connect two end stations back-to-back, use a crossover cable.

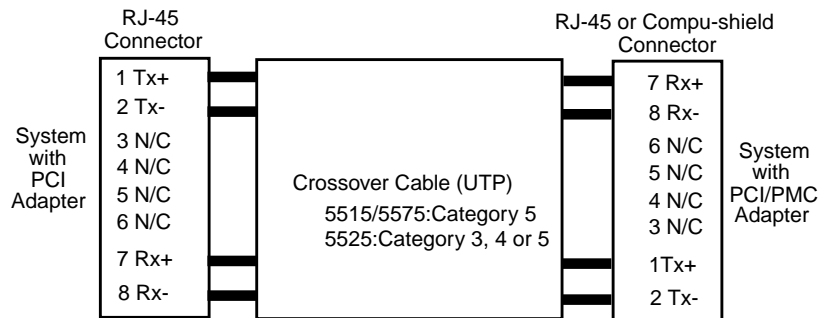

RJ-45 Connector Pinouts



CAUTION

For straight-through and crossover cabling to meet EMI specifications, the unused pairs must be connected at both ends of the cable to the Compu-shield and/or RJ-45 connectors.

RJ-45 Connector Pinouts

Pin assignments for the RJ-45 connector are as follows:

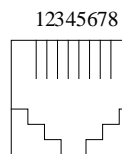

Pin #	Signal
1	Transmit (Tx+)
2	Transmit (Tx-)
7	Receive (Rx+)
8	Receive (Rx-)

PCI/PMC Technology Overview



PCI/PMC Technology

Intel® Corporation's Architecture Lab, along with leading computer vendors (the PCI SIG), designed the Peripheral Component Interconnect (PCI) bus as the next generation I/O expansion bus. Its predecessors were the ISA, EISA, and MCA buses. The PCI bus is a high-performance bus found in systems ranging from low-end PCs to high-end servers.

PCI was developed to overcome the bottlenecks associated with traditional 16-bit expansion slots, operating at 8 MHz, or essentially 5 megabytes per second. The result was a local bus system capable of transferring 32 bits of data at 33 MHz for a maximum data transfer rate of 132 megabytes per second. The PCI Local Bus takes peripherals off the I/O bus and connects them together with the CPU and the memory subsystem. This provides a wider, faster pathway for data, which is especially important for servers, graphic-intensive software, high-speed networks, and other high-performance peripherals.

Features of the PCI Local Bus architecture include:

- Processor-independent bridge between the CPU and high-speed peripherals that serves as a traffic controller between buses
- 32-bit memory addressing for CPU, Direct Memory Access (DMA) devices, and bus masters
- 32-bit data transfers at 33 MHz for CPU, DMA, and bus master devices
- 132 MBps maximum data transfer rate
- Data is written and read from the peripherals in linear bursts at every clock cycle

PCI/PMC Technology

- Buffers located between the peripherals and the CPU that allow multiple, high-speed peripherals to be attached to the same PCI local bus
- Automatic configuration of system and expansion boards

Three sizes of PCI add-in boards are defined: long, short, and variable short length. Systems are not required to support all board types. To accommodate the 5V and 3.3V signalling environments and to facilitate a smooth migration path between the voltages, three add-in board electrical types are specified: a “5 volt” board which plugs into only 5V connectors, a “universal” board which plugs into both 5V and 3.3V connectors, and a “3.3 volt” board which plugs into only 3.3V connectors.

The PMC bus was designed for embedded environments. It implements PCI bus logic in a daughtercard (mezzanine) form factor.

CompactPCI is another PCI form factor which implements PCI bus logic in a Eurocard 3U or 6U format with a high-density connector. This form factor is used in environments similar to the more traditional VME bus. The PCI Industrial Computer Manufacturers Group (PICMG) is developing the CompactPCI standard.

ATM Technology Overview

D

Introduction to ATM

Asynchronous Transfer Mode (ATM) is a switched, connection-oriented technology that allows voice, data, images, and video to be sent over the same network media. With significantly higher bandwidths than legacy LANs such as Ethernet and Token Ring, ATM supports applications such as multimedia and teleconferencing with a quality of service that is unavailable from other networks.

In addition, ATM can be scaled down to interface with a wide range of existing network configurations, as shown in Figure D-1. This flexibility is a result of ATM's inherent scalability, which extends from desktops to supercomputers.

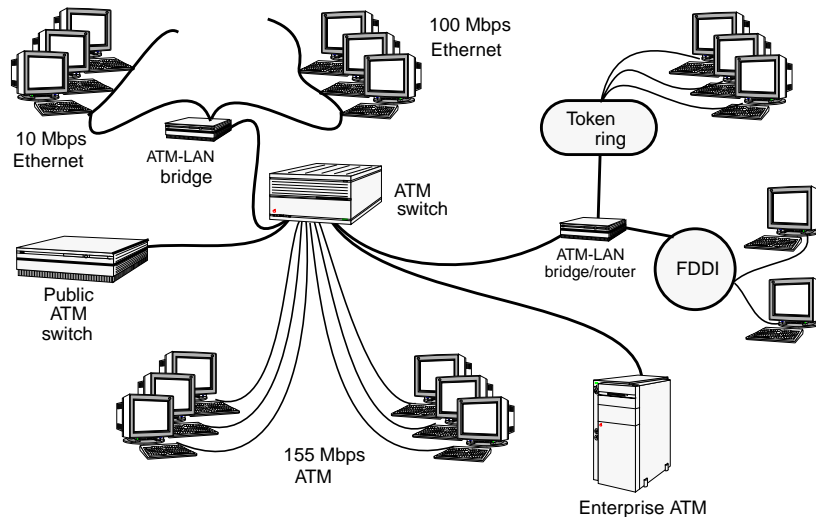

Figure D-1. ATM Network Topology

Virtual Circuits

The core concept of ATM is cell switching. Cell switching combines the benefits of packet switching, as used in traditional data networks, with circuit switching, as used in voice communications.

With ATM, all data, voice, and video information is converted into small, fixed-length packets, called *cells*, of 53 bytes each. These cells provide a standard way to combine the transmission rates required by bursty, variable-length packets of data and images with the constant, average rates required by voice and full-motion video. Transmitting fixed-length cells virtually eliminates the traditional overhead delays encountered with variable-length packets.

Virtual Circuits

ATM uses *virtual circuits (VCs)* to create individual communication links between network nodes for transporting the 53-byte fixed-length cells. These virtual circuits carry all transmissions between nodes. They maintain the correct cell sequence throughout the length of the transmission and provide a defined Quality of Service (QoS).

ATM networks use two types of virtual circuits:

- Permanent virtual circuits (PVCs)
- Switched virtual circuits (SVCs)

The path or connection used by virtual circuits is the *virtual circuit connection (VCC)*.

Virtual Circuit Connections

A virtual circuit connection (VCC) is a path or connection between any source and any destination in the ATM network. A VCC between two stations is configured manually for

PVCs, and dynamically, via signalling, for SVCs. All communication between the two stations proceeds along the same VCC.

The ATM cell header's virtual circuit identifier (VCI) is assigned per network VCC link, that is, end station-to-switch, switch-to-switch, switch-to-end station, and so on.

The *virtual path* (VP) creates groups of the VCs carried between the ATM entities, such as the ATM switches shown in Figure D-2:

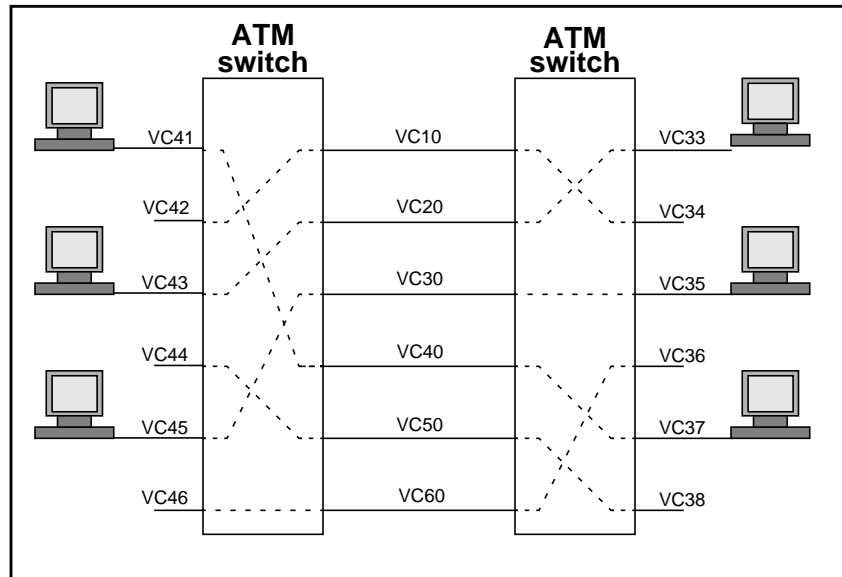

Figure D-2. Virtual Circuits

The VCs associated with a VP are globally switched without unbundling or processing the individual VCs. Thus, the cell-carrying capacity of each VC is preserved, and the quality of service of the VP can be scaled to extremely high speeds.

Permanent Virtual Circuits

Permanent virtual circuits (PVCs) are permanent, static connections between network nodes. With PVCs, the nodes operate as if they are connected with a dedicated physical line.

PVCs must be configured manually. To implement PVCs in an ATM network, you must create individual tables at each station and a master table at the switch. The table for each station must list the VCIs that identify the first steps in the paths leading to other stations with which the station is to communicate. At the switch, the master table must link all the information in the individual station tables.

When you move a station, you must recreate its table and also recreate its information in the switch's master table so that the station can reconnect to the network.

Switched Virtual Circuits

Switched virtual circuits (SVCs) are similar to voice telephone network connections; temporary connections between any two end points on the network are created dynamically for each session and torn down when the information exchange is complete. SVCs are created by signalling software in the end stations and the switches. This dynamic configuration eliminates the manual work required to implement PVCs.

With SVCs, the ATM switch only has to identify the output port to which to route a received cell and identify the new VPI/VCI on the output link.

Fixed-Length Cells

Fixed-length cells of 53 bytes each are transmitted over the VC established between the sending node and the receiving node. As shown in Figure D-3, each cell contains the following:

- A 5-byte header for connection identification, flow control, routing, and error control
- 48 bytes of data

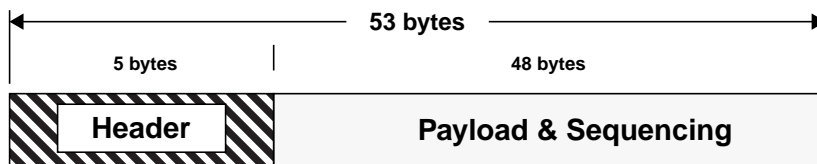

Breakdown of 5-byte Header

	Bits 0-3	Bits 4-7
Byte #1	GFC/VPI*	VPI
Byte #2	VPI	VCI
Byte #3	VCI	
Byte #4	VCI	Payload Type CLP
Byte #5	Header Error Control	

GFC: Generic Flow Control **VPI:** Virtual Path Identifier
VCI: Virtual Circuit Identifier **CLP:** Cell Loss Priority bit

* First 4 bits are used as GFC field in the case of User-Network Interfaces.

Figure D-3. The ATM Cell

Scalability

The fixed-byte count allows fast hardware switching, lowers processing requirements, and practically eliminates the overhead associated with processing variable-length packets. As a result, ATM cells can be transmitted through multiple, contiguous connections and still maintain the time-sensitive quality of service required for audio and video applications.

Scalability

A major benefit of ATM is its inherent ability to support many different access and transmission speeds on different physical media. This is referred to as *scalability*.

For example, a cell generated on a 155 Mbps ATM LAN can be carried over a 45 Mbps asynchronous DS3 line to a network in a different location. From there, the cell can be switched into a 2.4 Gbps SONET (synchronous) transport system.

ATM networks can allocate a guaranteed amount of bandwidth for fixed-bit-rate, delay-sensitive transmissions such as video and voice data. And they can allocate a variable amount of bandwidth for the balance of network data that is less delay-sensitive.

ATM Layers

The B-ISDN (Broadband Integrated Services Digital Network) model defines three ATM layers:

- Physical Layer
- ATM Layer
- ATM Adaptation Layer (AAL)

In comparison with the OSI model, the three ATM layers are similar to the Physical Layer (Layer 1) and a portion of the Data Link Layer (Layer 2):

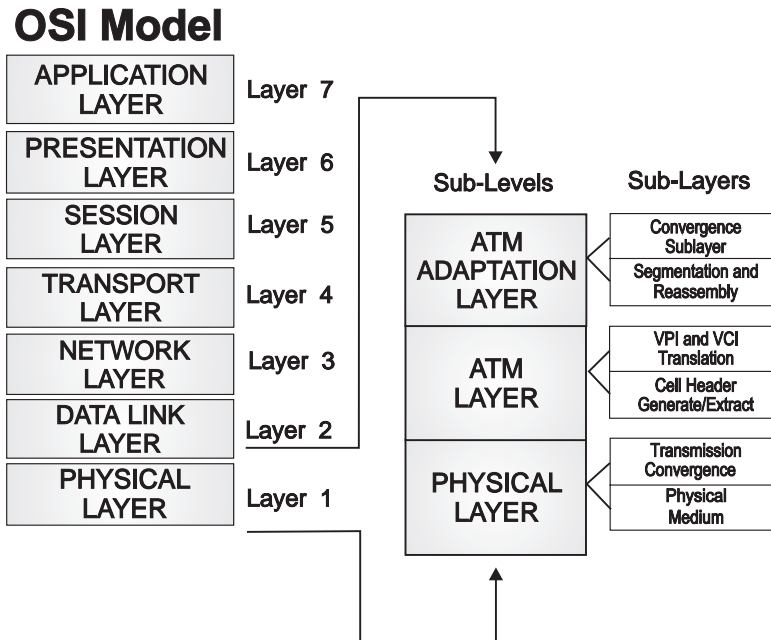

Figure D-4. ATM Compared to the OSI Model

Physical Layer

The ATM Physical layer defines the interface and framing protocol for the ATM network. The ATM Physical layer has two sublayers:

- The PMD sublayer provides bit transfer functions that are specific to the medium used in the network.
- The TC sublayer controls the transmission of frames over the physical medium.

ATM Layers

ATM Layer

The ATM Layer defines the cell structure and how cells move between connections in an ATM network. This layer creates the cells and controls the setup and teardown of virtual connections and virtual paths in the network.

ATM Adaptation Layer

The ATM Adaptation layer (AAL) enhances the services provided by the ATM layer to better serve the next higher layer's functions. It provides timing and sequencing information tailored to the upper layer it is working with. It converts this information and the data being sent to ATM cells according to its rules. It then converts the ATM cells back to data after they reach their destination.

AAL is classified into four classes of service. For each class, AAL consists of two sublayers. The different service classes vary in the form of data transfer they support and in their sublayer structures.

AAL Service Classes

The currently defined AAL service classes are:

- **AAL1**
- **AAL2**
- **AAL3/4**
- **AAL5**

AAL1

AAL1 service supports the transfer of constant bit rate (CBR) data and provides mechanisms for maintaining timing and structure information for that data. It is primarily intended for transporting small data samples, such as voice.

AAL2

AAL2 service is not yet standardized. Its definition is currently under development by the ITU.

AAL3/4

AAL3/4 service supports the transfer of data that is sensitive to cell loss, but less sensitive to delay than AAL1-type data. AAL3/4 segments upper-layer data into cells, each of which consists of:

- A 2-octet header
- 44 octets of protocol data unit (PDU) payload
- A 2-octet trailer

The header and trailer provide message- and cell-level sequencing, as well as per-cell CRC. This cell-level management comes at the cost of the additional overhead octets in each cell. AAL3/4 is rarely used.

AAL5

AAL5 service, like AAL3/4, supports the transfer of data that is less sensitive to delay than AAL1 data. AAL5 is a simpler and more space-efficient protocol than AAL3/4. It relies on higher-level services to handle cell loss and other errors.

AAL5 encapsulates upper-layer SDUs into PDUs. Each PDU has a single trailer, which contains the upper-layer SDU control information, SDU length, and a CRC to guarantee the

ATM Layers

integrity of the entire PDU. AAL5 then segments the PDU into cells, each of which uses the entire 48-octet cell payload to deliver user data.

AAL Sublayers

The AAL for all service classes consists of two sublayers:

- **The Segmentation and Reassembly (SAR) sublayer** converts data into cells, and cells back to data.
- **The Convergence Sublayer (CS)** meets the specific service requirements of the next higher layer.

In AAL3/4 and AAL5, the Convergence Sublayer consists of two further sublayers:

- **The Service Specific Convergence Sublayer (SSCS)** handles details of the higher layer's specific services.
- **The Common Part Convergence Sublayer (CPCS)** converts upper-level SDUs to AAL PDUs.

Figure D-5 illustrates the protocol model for AAL3/4 and AAL5 sublayers:

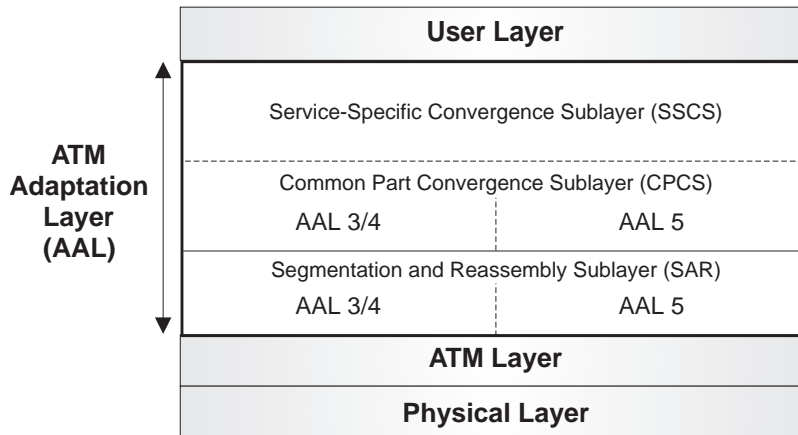

Figure D-5. Protocol Model for AAL3/4 and AAL5

Figure D-6 illustrates how the AAL5 sublayers handle data segmentation:

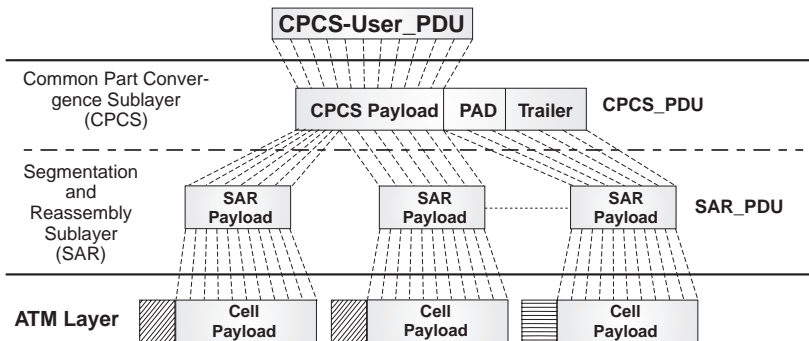

Figure D-6. AAL5 Sublayers

SONET/SDH

SONET (Synchronous Optical Network) is a North American multiplexing standard that defines a signal used in optical fiber networks. For ATM over fiber, OC-3c, with a base rate of 155.520 Mbps, is the most widely-used signal in the US.

SDH (Synchronous Digital Hierarchy) is the European equivalent of SONET. STM-1 (Synchronous Transport Mode, Level 1) is the European equivalent of OC-3c. Like OC-3c, STM-1 has a base rate of 155 Mbps, but STM-1 has slightly different framing information than the OC-3c signal.

Integrated Local Management Interface

Integrated Local Management Interface (ILMI) is the ATM Forum specification for incorporating network management into ATM networks. ILMI is based on the Simple Network Management Protocol (SNMP). The Interface Management Entities (IMEs) on the end station and the switch use ILMI to manage the physical link connecting them.

A subset of ILMI, known as *address registration*, is used when a station is connected to the ATM network. Address registration lets the end station and the switch dynamically build a unique ATM End Station Address (AESA). The AESA consists of two parts, the end station identifier (ESI) and the network prefix, which are concatenated together to define the end station's unique ATM network address.

- The ESI is the ATM adapter's unique 6-byte identifier.
- The network prefix is the 13-byte link address, as determined by the ATM switch.

LAN Emulation

LAN Emulation (LANE) is designed to allow existing network applications and network protocols to run over ATM networks. It supports ATM as a backbone for connecting *legacy* networks such as Ethernet, FDDI, and Token Ring. It supports efficient interaction for both directly-attached ATM end systems (in their own subnet) and legacy end systems attached through Layer 2 bridging devices.

LAN Emulation allows multiple emulated LANs (ELANs) to exist on the same physically interconnected ATM network. For example, using an appropriate ATM network interface card, an ATM end station can communicate with all of the following:

- An Ethernet segment on one ELAN
- A Token Ring segment on a second ELAN
- An FDDI segment on a third ELAN
- A fourth ELAN comprised of ATM nodes only (taking full advantage of high-speed ATM communications)

LAN Emulation Multiple Protocol Support

LAN Emulation supports a wide variety of protocols primarily because the functionality of the LANE interface is defined at the MAC layer. This allows for protocol-independent data transfer between devices attached to the ELAN and to other legacy-attached devices, as shown in Figure D-7:

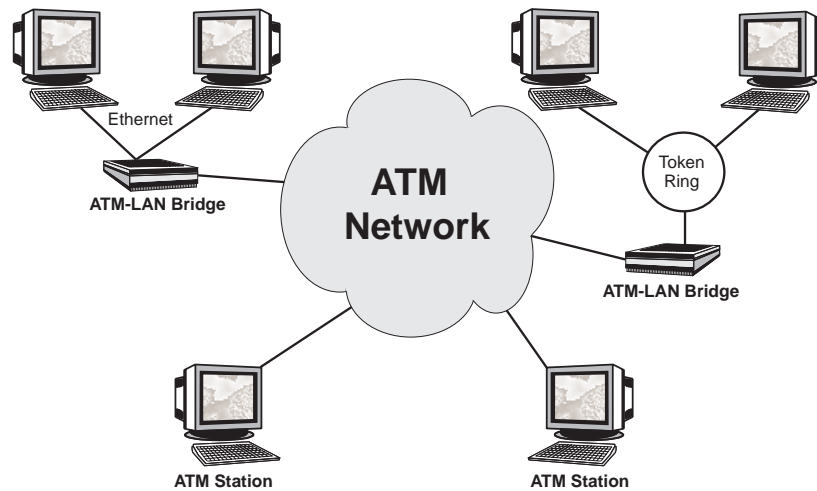
LAN Emulation**Figure D-7. ATM LAN Emulation****MAC-Dependent Protocol Support**

However, LAN Emulation does not support protocols or applications that are dependent on MAC layer protocols, such as SMT/Token Management and CSMA/CD. These MAC-dependent applications are designed to deal with specific media issues such as ring arbitration and collision detection. In addition, because each ATM link carries traffic destined only for the one station attached to that link, a given station cannot receive all of the ELAN's frames like it would on a shared media network.

Therefore, removing the old equipment and installing LAN Emulation-based ATM equipment does not solve existing Ethernet/Token Ring/FDDI bridging problems.

Legacy LAN Protocol Support

LAN Emulation enables legacy LAN applications to operate over ATM while hiding the complexities of ATM point-to-point connections. With LAN Emulation, an ATM switch arranges ATM stations into groups that can implement and receive each other's broadcast/multicast requests. LAN Emulation supports requests in Ethernet and Token Ring frame formats, enabling legacy applications to run without modification over ATM networks. (LANE Emulation also supports FDDI, which uses Ethernet frames.)

LAN Emulation implements this frame format support with true MAC-level bridging. Multiple protocols, such as IP, IPX, and NetBIOS, can communicate across the ATM-LAN bridge. To illustrate how LAN Emulation works, Figure D-8 shows how an ATM host, an ATM-LAN bridge, and a legacy LAN host fit into the same network.

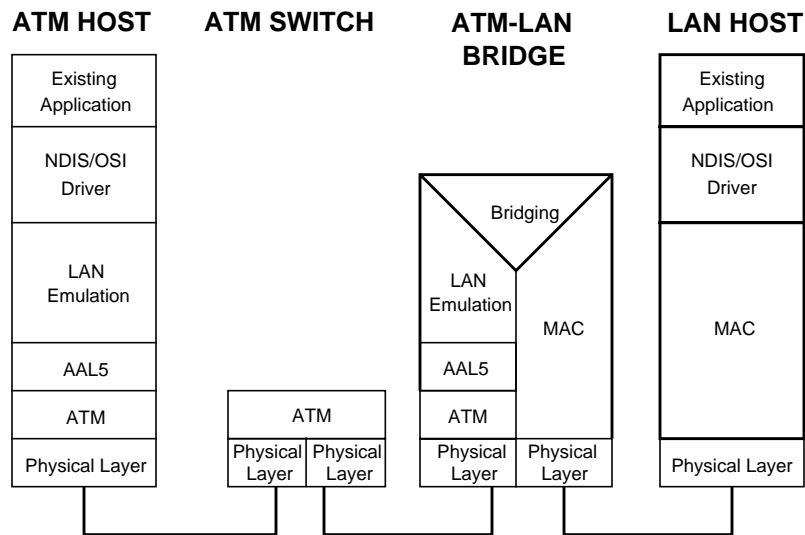

Figure D-8. LAN Emulation Protocol Stack

LAN Emulation

The goal of LAN Emulation (on the ATM side of the bridge) is to convince the upper layer protocols that a MAC layer of a legacy LAN lies in the lower layers, when actually it does not. The only discernible difference is that ATM's emulated LAN interface operates at much higher transmission rates.

All LAN Emulation connections (as defined by the ATM Forum) use the AAL5 ATM Adaptation layer to reassemble and segment the PDUs of legacy LANs into 53-byte ATM cells. The ATM-LAN bridge implements the MAC layer emulation to and from the legacy LAN. As illustrated by the LAN Host diagram in Figure D-8 on page 147, existing software requires no changes to run over ATM networks. ATM switches transport the cells just as they would for any other connection.

LAN Emulation Services

The LAN Emulation Client (LEC) defines the interface between a MAC layer entity of an ATM node and the emulated LAN. The LAN Emulation Service defines how the protocol interoperates with multiple LECs. It provides functions for initialization, address registration and resolution, and data forwarding. The three components that implement these functions are:

- LAN Emulation Configuration Server (LECS)
- LAN Emulation Server (LES)
- Broadcast and Unknown Server (BUS)

Some vendors provide these services in one or more switches, while others provide them in end station or edge devices.

LAN Emulation Configuration Server

The LECS provides a central point of contact for each LEC on the ATM network. It provides each LEC with configuration information, including the address of the LES that serves a specific ELAN. At bootup, LECs initially communicate with the LECS to locate the appropriate LES for their emulated LAN. The connection between the LEC and the LECS can be terminated when this transfer of information is complete.

Network personnel implement and maintain LECS information. Depending on the vendor, the LECS implementation might also provide numerous features such as support for multiple ELANs, ELAN management based on MAC addresses, and other network management features.

LAN Emulation Server

The LES provides LAN Emulation address resolution. This is a critical function because MAC addresses are 6-byte entities and ATM addresses are 20-byte entities. Each LEC notifies the LES of its MAC-ATM address bindings. The LES stores the MAC-ATM relationship so it can resolve queries from other clients for these MAC addresses.

All LECs on an ELAN connect to the same LES. All LECs on the same ELAN must log in with the LES before attempting to communicate with any other LEC in the group. They also must use the same Maximum Transfer Unit (MTU) size. An ELAN's MTU size depends on what type of legacy edge devices (if any) are being supported.

If the network interface card at the ATM node supports multiple LECs, each LEC on the card can be configured to a different ELAN and have a different MTU size than the other

LAN Emulation

LECs. For example, three different LECs on the card might be configured as follows to communicate with nodes on three different ELAN types:

- LEC1 is configured to use a 1.5K MTU size to communicate with nodes on Ethernet subnets.
- LEC2 is configured to use a 4.5K MTU size to communicate with nodes on Token Ring and FDDI subnets.
- LEC3 can use a 9K (or maximum rate) MTU size to communicate with all ATM-only nodes on the ELAN.

If clients require more than one ELAN with the same MTU size, network personnel can configure differentiating characteristics (for example, logical names) in the LECS.

The connection between the LES and each LEC is open as long as the LEC is up and running. The LES maintains information about all LECs currently connected to the server. When a LEC is disconnected or turned off, the LES removes all information about the LEC.

Therefore, ATM networks using LAN Emulation support relocation of end stations with ease. Moving a station is a matter of physically moving the hardware to a new location, connecting it to the same or another ATM switch in the network, and turning on the power. At bootup, each client contacts the LECS; the LECS supplies the ATM address for the appropriate LES; the client joins the LES, and can then start communicating with other clients on that ELAN.

Broadcast and Unknown Server

The Broadcast and Unknown Server (BUS) provides a simplified mechanism to support both broadcasting and bridged network functionality. Most protocols use the network

topology's shared media broadcast capabilities to implement the mechanism for translating network addresses to MAC addresses.

Because ATM is inherently non-shared, additional work must be done to enable every station on an ELAN to receive the broadcast and multicast frames. The BUS is a centralized server for the ELAN that accepts broadcast traffic from all clients in the group and then forwards that traffic to all the clients on a point-to-multipoint connection.

LAN Emulation Protocol

This section describes how the various phases of the LAN protocol accomplish the goal of getting multiple stations to communicate in the ATM network environment. The LAN Emulation protocol phases are:

1. Initialization
2. Configuration
3. Joining
4. Registration and BUS initialization
5. Data movement

Initialization

At power-up or reset, during initialization, a LEC's first action is to establish a connection with an LECS. The protocol defines a multi-step procedure to ensure that the LEC can reach the LECS in a variety of environments.

LAN Emulation

The first mechanism involves getting the LECS address(es) via ILMI. If no addresses are listed, or if none of the addresses work, the LEC uses the *well-known* ATM address (defined by the ATM Forum). An error occurs if this address does not work.

Additionally, as an out-of-band mechanism for obtaining the required configuration, network personnel can enter the address of the appropriate LES directly in the LEC setup.

Configuration

After the LEC establishes a connection to the LECS, the LEC transmits a message to the LECS. The message provides the LEC's ATM address, MAC address, LAN type, and frame size (MTU) request. When the LECS validates the request, it returns configuration information about the appropriate LES, including the LES's ATM address and the LAN type and frame size for the LEC to use for the session.

Joining

When the LEC gets the ATM address of the LES, it attempts to join the ELAN by creating a permanent connection to the LES. When it connects, the LEC transmits a message to the LES providing the configuration information obtained from the LECS and, optionally, a MAC address to register. A separate registration message can be used to register additional MAC addresses. The join process culminates in the LES adding the client as a leaf to its point-to-multipoint tree.

Registration and BUS Initialization

Upon joining the LES, the LEC requests the ATM address for the *all 1's* broadcast MAC address. The LES responds with the ATM address for the Broadcast and Unknown Server.

The LEC then initiates a Multicast Send connection to the BUS and accepts the incoming Multicast Forward multipoint VCC from the BUS.

Data Movement

After BUS connections are established, the LEC can begin forwarding frames. When a data frame needs to be transmitted, the LEC checks an internal table to see if a connection already exists for the destination MAC address. If so, it transmits the frame on that VCC. Otherwise, it queries the LES for the ATM address that corresponds with the MAC address. While waiting for a response, it forwards the frames destined for this MAC address to the BUS.

For a device on the legacy side of a bridge, the bridge learns the device's MAC address when the device starts transmitting. Then future requests to resolve the MAC address result in the bridge responding with its own ATM address.

Connections time out after periods of 20 minutes of inactivity in both directions. MAC entries received from the bridges are also timed out and reverified. This is done to support station movement on the legacy network where the edge devices do not have definitive knowledge of station movement activity.

LAN Applications

The advantage of LAN Emulation is that existing applications and protocols can be adapted to ATM merely by installing new ATM interfaces and drivers. The disadvantage is that these driver interfaces do not utilize any of the benefits of ATM, such as a varying quality of service, full ATM addressing, and other non-LAN protocol applications.

Multiprotocol Encapsulation over ATM AAL5

For future software designs, the ATM Forum has developed a Native Service Interface, which defines how new applications can be adapted to ATM networks, multiple vendors, and WinSock 2 support. This development provides an evolutionary solution where existing applications can continue to work as before, while new applications can take full advantage of ATM capabilities. The two interfaces are able to coexist in the same end systems.

Multiprotocol Encapsulation over ATM AAL5

The Internet Engineering Task Force (IETF) defines Multiprotocol Encapsulation over ATM AAL5 in RFC-1483. Multiprotocol Encapsulation over ATM AAL5 provides methods for encapsulating existing network protocol frames so that they can be transported over ATM in AAL5 frames. This encapsulation enables higher-layer protocols to use ATM networks to interconnect and exchange existing frame types.

RFC-1483 defines two encapsulation methods:

- The first method, *LLC encapsulation*, allows different frame types to be multiplexed over the same ATM VC. LLC encapsulation uses IEEE 802.2 Logical Link Control (LLC) headers to differentiate frame types. This is the primary method used in most environments.
- The second method, known as *VC Based Multiplexing* or *Null Encapsulation*, allows one frame type to exist on the VC because no encapsulation is used.

There are two classes of protocol frames:

- Routed protocols

An example of a routed protocol is IP, which is the encapsulation defined in RFC 1577 to carry IP data over ATM networks.

- Bridged protocols

Examples of bridged protocols are Ethernet and FDDI, which many ATM PVC services use to interconnect like legacy networks.

Specific encapsulation rules are spelled out for each class. In general, the LLC header identifies the encapsulated payload.

Classical IP over ATM

Classical IP (CIP) over ATM is designed to allow existing unicast IP network applications to run over ATM networks. The Internet Engineering Task Force (IETF) defines Classical IP in RFC 1577. Classical IP over ATM uses LLC Encapsulation for Routed Protocols, as defined in RFC-1483, for data encapsulation.

Figure D-9 on page 156 illustrates a Classical IP over ATM network configuration. Figure D-10 on page 156 illustrates the Classical IP over ATM protocol stack.

Classical IP over ATM

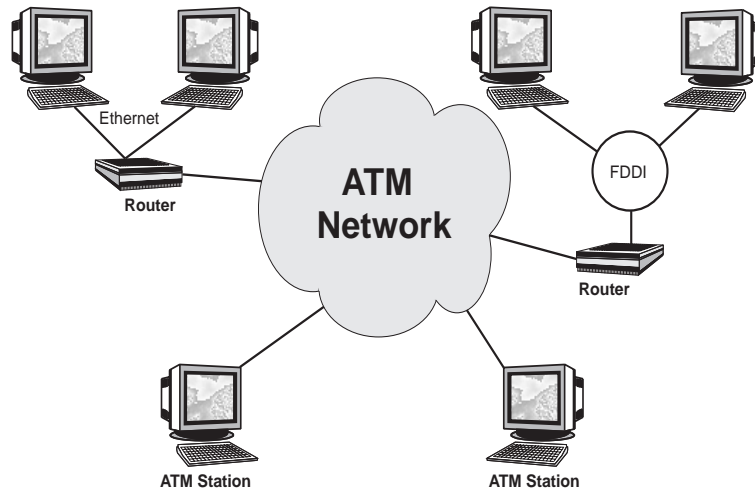

Figure D-9. Classical IP over ATM

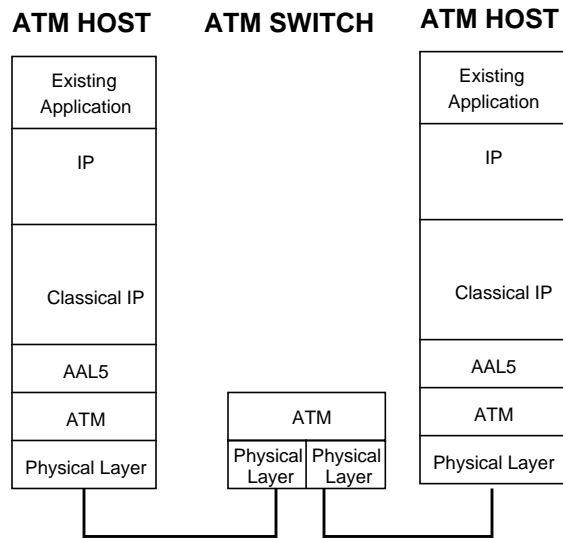

Figure D-10. Classical IP Protocol Stack

Classical IP Client Interface

The CIP Client defines the interface between an IP layer entity of an ATM node and the Logical IP Subnetwork (LIS). The standard supports only the delivery of unicast IP packets over ATM networks. To transfer a unicast IP packet, the CIP client must translate the IP address to an ATM address, create an SVC to that host, and then pass LLC encapsulated IP data over that VC.

The ATM ARP Server provides address resolution service to CIP clients. The ATM Address Resolution Protocol (ATMARP) defines how a CIP client can obtain the ATM address of an IP client it wants to connect to. This is done with ARP on broadcast enabled networks. Because the ARP protocol requires a broadcast medium, IP over ATM networks use an additional protocol, the Inverse ATM Address Resolution Protocol (InATMARP), which is based on the Inverse Address Resolution defined in RFC 1293.

ATM ARP Servers use InATMARP to discover client address information. IP clients connected by PVC use InATMARP to discover address information about the remote end.

Most vendors provide ATM ARP Server services in one or more switches or ATM-attached devices such as routers.

Classical IP ARP Server

The ARP Server provides address resolution functions for clients on a Logical IP Subnet. Each client connects to the server via an SVC as it comes up on the ATM network or when it needs to resolve the address of another IP attached device. When the client connects, the server acquires the client's ATM to IP address mapping by means of InATMARP and builds a

Classical IP over ATM

table of all the IP addresses on the LIS. Then when a client asks for the mapping via ATMARP, it can return the ATM address the client needs to create an SVC to the device.

Data Movement

When the ARP Server connection is established, the CIP client resolves IP to ATM address mappings and directly connects to other CIP Clients. When it needs to transmit a data frame, the client checks an internal table to see if a connection already exists for the destination IP address. If so, it encapsulates that frame with an LLC/SNAP header and transmits the frame on that VCC.

Otherwise, it queries the ARP Server for the ATM address that corresponds to the IP address. The Client then sets up an SVC to that ATM address and transmits the frame. For a device on the legacy (such as Ethernet) side of a router, the router's IP address must be configured as the gateway for the legacy subnet or as the default gateway for all unknown IP addresses not resolved by the ARP Server.

CIP Applications

The advantage of CIP is that existing IP unicast applications can be adapted to ATM merely by installing new ATM interfaces and drivers. They also perform better than other types of applications because of the larger MTU size supported by CIP.

The disadvantage is that the ATM driver interfaces do not utilize any of the benefits of ATM beyond its bandwidth and larger MTU support. The driver interfaces also do not support broadcast or multicast applications under CIP.

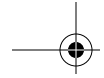

For More Information

For more information about ATM networking, see
<http://www.atmforum.com>

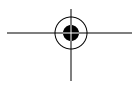



For More Information



Glossary

The ATM Forum's glossary can be found on the Internet at <http://www.atmforum.com/atmforum/glossary/glosspage.html>

The following glossaries may also be helpful:

- Networking Glossary: <http://www.ctcnet.com/tips/glossary.htm>
- Computing Dictionary: <http://wfn-shop.Princeton.EDU/foldoc/>

802.2 IEEE ♦ Standards that govern the LLC within the Data Link layer of the OSI model. LLC frames carry user information between the nodes on a network and define the transmission of a frame between two stations. These standards are common across the various lower level standards within the Data Link and the Physical layers.

802.3 IEEE ♦ Standards that govern the use of the CSMA/CD (Carrier Sense Multiple Access/Collision Detection) network access method used by Ethernet networks.

802.5 IEEE ♦ Standards that govern the use of the token ring indicator and frame priority.

AAL (ATM Adaptation Layer) ♦ Converts packets of data to 53-byte cells for transmission on the network. Several AALs are defined to provide different types of service for ATM connections, and to provide a method of mapping data from a particular class of service into ATM cells in such a way that the data can be remapped into its original format at the other end of an ATM network.

ABR (Available Bit Rate) ♦ One of the two non-guaranteed service types (the other is UBR). With ABR, the network makes no absolute guarantee of cell delivery, but does guarantee a minimum bit rate for user transmission. ABR also makes an effort to keep cell loss as low as possible through a closed feedback loop conveying congestion information back to the source so the source can adjust its rates.

adapter ♦ A device, usually a user interface card, that physically connects an end station to the network medium (for example, twisted pair, coaxial, fiber).

address registration ♦ A subset of ILMI which enables the switch and end station to dynamically construct an end station address.

Glossary

AESA (ATM End Station Address) ♦ The 20-byte address defined by the ATM Forum for identifying end stations on a private ATM network.

ANSI (American National Standards Institute) ♦ An organization which coordinates, develops, and publishes standards used in the United States.

ARP (Address Resolution Protocol) ♦ The Internet protocol used to dynamically translate the Internet address of a network host to its LAN hardware address. This action is limited to LANs that support hardware broadcasts.

ASIC (Application Specific Integrated Chip)

ATM (Asynchronous Transfer Mode) ♦ A switched, connection-oriented technology for LANs and WANs. ATM accommodates a mix of data types, such as audio, video, and data, on a single network. The multiplexed information is organized into cells, and can be transported between network nodes at many different access and transmission speeds. Synonyms: asynchronous transmission, cell relay.

ATM Forum ♦ A communications industry organization made up of hundreds of vendors and users that defines ATM networking protocols.

ATM LAN ♦ Topology that consists of ATM switches and computer interfaces that provide high data rate connectivity for voice, video, and data (IP and multimedia). In addition, ATM interfaces are being integrated into existing LAN hubs and bridge/router platforms. Besides supporting high bandwidth, ATM LANs map to the WAN via central office ATM switches and services being deployed in the telecommunications world.

attenuation ♦ Signal power lost in a transmission medium as the signal travels from sender to receiver.

backbone ♦ A network configuration that connects LANs to form an integrated network.

bandwidth ♦ Capacity for transmitting data through a given circuit. Generally, the greater the bandwidth, the more information can be sent through a circuit during a given amount of time.

best effort ♦ A QoS class where no specific traffic parameters and no attempts are made to guarantee no cell loss or delay variation.

B-ISDN (Broadband ISDN)

bridge ♦ An internetworking device used to connect two or more computer networks at the MAC level, and to forward MAC packets among those networks.

BUS (Broadcast and Unknown Server) ♦ A LAN emulation server for ATM networks which has the ability to receive broadcast requests and forward them to all the attached LECs, thus emulating the broadcast feature of Ethernet and Token Ring LANs.

CAC (Connection Admission Control) ♦ An ATM function which determines whether a VC connection request should be accepted or rejected.

call control ♦ A process that uses signalling procedures to establish VCs. These connections are much like telephone calls. Synonym: call setup.

CAT-3 (Category 3 UTP) ♦ A type of UTP commonly used with ATM interfaces for cell transmission at low speeds (25 Mbps) and at distances up to 100 meters.

CAT-5 (Category 5 UTP) ♦ A type of UTP commonly used with ATM interfaces for higher-speed cell transmission (155 Mbps).

CBR (Constant Bit Rate) ♦ The continuous transmission of data at a fixed and guaranteed rate over a network with a guaranteed cell delay variation.

CCITT (International Telephone and Telegraph Consultative Committee) ♦ See *ITU (International Telecommunication Union)* on page 166.

CDV (Cell Delay Variation) ♦ A QoS parameter that measures the difference between a single cell's transfer delay (CTD) and the expected transfer delay. It gives a measure of how closely cells are spaced in a VC. CDV can be introduced by ATM multiplexers (MUXs) or switches.

cell ♦ Basic ATM transmission unit. A 53-byte packet comprised of a 5-byte header and a 48-byte payload. User traffic is segmented into cells at the source, transmitted through the ATM switched network, and reassembled at the destination.

cell FIFO ♦ Optimized DMA of ATM cells from reassembly engine to system memory requiring minimal CPU intervention.

cell switching ♦ ATM technology that combines the best features of circuit-and packet-switching technology and supports several classifications of AAL service (voice/video, packet/video, data).

circuit switching ♦ A connection-oriented service that uses switching techniques such as time division. It is an ideal mode for continuous, constant bandwidth applications, such as voice and video.

Glossary

CLIP (Classical IP) ♦ A set of IETF-defined protocols for developing IP over ATM networks. The main issues in the transport of IP over ATM that CLIP resolves are packet encapsulation and address resolution.

CLP (Cell Loss Priority) ♦ A 1-bit field in the ATM cell header that corresponds to the loss priority of a cell. Lower-priority (CLP=1) cells can be discarded in congestion situations.

compression ♦ Method of reducing the quantity of data that must be transmitted across a network, primarily to enable the transmission of voice and video. The major compression standards are JPEG for still images, MPEG/MPEG-2 for full-screen motion images, and Px64 and H.261 for video conferencing.

configuration cycle ♦ A type of I/O cycle provided on the PCI bus to facilitate system configuration.

CPC (Cell Personality Card)

CPCS (Common Part Convergence Sublayer) ♦ Part of the AAL convergence sublayer (CS), it must be present in the AAL implementation. Its task is to pass primitives to the other AAL sublayers (SAR, SSCS). It supports the functions of the standardized Common Part AALs: AAL1, AAL3/4, and AAL5.

CRC (Cyclic Redundancy Check) ♦ A bit errors detection technique that employs an algorithm to calculate a value for the information bits in a packet. The receiver, using the same algorithm, recalculates that value and compares it to the value received. If the two values do not agree, the transmitted packet is considered to be in error.

DLE (DMA/Descriptor List Element) ♦ The structure that describes to the PCI bus interface how to move data between the packet buffer and system memory.

DMA (Direct Memory Access) ♦ A fast method of moving data between two subsystems without processor intervention.

DS3 (Digital Standard 3) ♦ This ANSI standard defines the format of asynchronous data sent at the rate of 44.736 Mbps.

E.164 ♦ An ITU-defined 8-byte address format. In ATM it is typically used in public networks and is provided by the telecommunication carriers, while 20-byte NSAP-format addresses are used in private networks.

EFCI (Explicit Forward Congestion Indication) ♦ A 1-bit field in the cell header that contains information about whether congestion at an intermediate node has been experienced. The EFCI bit is set when, for example, a buffer threshold has been exceeded. When recognized by end stations, causes a reduction in the data rate.

ELAN (Emulated LAN) ♦ See *LANE (LAN Emulation)* on page 167.

end station ♦ A machine, intended for running user application programs, that is connected to a network. In an ATM network, the end station is where an ATM connection is terminated or initiated.

ESI (End Station Identifier) ♦ Six-byte unique identifier that the end station concatenates to the network prefix during address registration to generate an ATM end station address (ESI).

fiber optic cable ♦ A transmission medium designed to transmit digital signals in the form of pulses of light.

FIFO (First In First Out) memory ♦ A type of dual-ported memory where the data is read out in the same order in which it was written in.

fragmentation ♦ A process where large frames from one network are broken up into smaller frames that are compatible with the frame size requirements of the network to which they will be forwarded.

frame ♦ Data in a highly-structured format for the purpose of transmission. *Frame*, *packet*, and *PDU* are equivalent in most contexts.

FTP (File Transfer Protocol)

GFC (Generic Flow Control) ♦ A field in the ATM cell header that supports multiplexing functions. The GFC mechanism is intended to support simple flow control in ATM connections.

HDLC (High-level Data Link Control) ♦ A framing protocol specified by the ISO that can provide error-free Data Link layer services.

header ♦ Control information attached to the front of a frame or packet. In ATM cells, the header is the bits in a cell allocated for functions required to transfer the cell payload within the network.

HEC (Header Error Control) ♦ A cell header CRC field that guarantees the integrity of the cell header information.

host ♦ Generally, any computer on a network.

host name ♦ A unique name that identifies each host machine on a network.

ICMP (Internet Control Message Protocol) ♦ A Network layer Internet protocol which enables network IP packets to report errors and other relevant information for packet-processing purposes.

Glossary

IEEE (Institute of Electrical and Electronic Engineers) ♦ An information exchange organization. Among other functions, it coordinates, develops, and publishes network standards for use in the United States, following ANSI rules.

IETF (Internet Engineering Task Force) ♦ Organization responsible for all Internet protocols (for example, IP, TCP, FTP).

ILMI (Integrated Local Management Interface) ♦ The ATM Forum standard, ILMI is used to manage the physical and logical interface between two ATM devices.

IME (Interface Management Entity) ♦ The logical management layer implementing ILMI.

IP (Internet Protocol) ♦ A networking protocol for providing a connectionless (datagram) service to the higher transport protocol. It is responsible for discovering and maintaining topology information and for routing packets across homogeneous or heterogeneous networks. Combined with TCP, it is commonly known as the TCP/IP platform.

IPX (Internetwork Packet Exchange Protocol) ♦ A connectionless Network layer protocol similar to IP.

ISDN (Integrated Services Digital Network) ♦ An early, CCITT-adopted protocol reference model intended to provide a ubiquitous, end-to-end, interactive digital service for data, audio, and video. Synonym: narrowband ISDN.

ISO (International Standards Organization) ♦ An international body that creates networking standards, including the OSI model.

ITU (International Telecommunication Union) ♦ The international standards organization for telecommunications, previously known as the CCITT (International Telephone and Telegraph Consultative Committee). For more information, see <http://www.itu.ch>

isochronous ♦ A time-slot protocol that allows delivery of realtime data by dividing a time slot into equal-size mini slots allocated to different channels for synchronous transmission of information.

jitter ♦ See *CDV (Cell Delay Variation)* on page 163.

KB (Kilobytes) ♦ One kilobyte is equivalent to 1024 bytes when referring to memory size, and 1000 bytes when referring to speed.

Kbps (Kilobits per second)

KBps (Kilobytes per second)

LAN (Local Area Network) ♦ A data communications system designed to operate over a limited geographic distance, such as a single building.

LANE (LAN Emulation) ♦ An ATM Forum service specification that allows a connection-oriented ATM network to emulate legacy LAN (for example, Ethernet or Token Ring) services, such as broadcast.

LAP-D (Link Access Procedure-D) ♦ A Data Link layer procedure using D channel communications, typical of ISDN.

LE-ARP (LAN Emulation ARP) ♦ The ARP used in LAN emulation for binding a requested ATM address to the MAC address.

LEC (LAN Emulation Client) ♦ Typically located in an ATM end system (for example, an ATM host), its task is to maintain address resolution tables and forward data traffic. It is uniquely associated with an ATM address.

LES (LAN Emulation Server) ♦ A server which provides support for the LAN emulation address resolution protocol (LE-ARP). The LECs register their own ATM and MAC addresses with the LES. An LES is uniquely identified by an ATM address.

LECS (LAN Emulation Configuration Server) ♦ A server whose main function is to provide configuration information to an LEC (such as the ELAN it belongs to or its LES).

LIS (Logical IP Subnet) ♦ IP subnet, which is fully contained in an ATM network and served by a Classical IP Server.

LLC (Logical Link Control) ♦ The upper half of the Data Link layer in LANs. Performs error control, broadcasting, multiplexing, and flow control functions. See also *MAC (Medium Access Control)* on page 167.

LLC/SNAP (Logical Link Control/SubNetwork Attachment Point)

local ♦ Describes files and devices, such as disk drives, that are attached to, or on, your machine.

MAC (Medium Access Control) ♦ A set of protocols that are the lower part of the Data Link layer and comprise the basis of the IEEE LAN specifications. In general, MAC determines the way devices can transmit in a broadcast network. See also *LLC (Logical Link Control)* on page 167.

Glossary

Mbps (Megabits per second) ♦ Transmission speed or rate of one million bits per second.

MBps (Megabytes per second) ♦ Transmission speed or rate of one million bytes per second or 8 Mbps.

MIB (Management Information Base) ♦ The specification that defines objects for referencing variables such as integers and strings. In general, it contains information about the network's management and performance (for example, traffic parameters). See also *ILMI (Integrated Local Management Interface)* on page 166.

MTU (Maximum Transmission Unit) ♦ The largest packet that can be sent over a given medium.

multicast ♦ A technique that allows copies of a single packet or cell to be passed to a set of destinations.

multimode fiber ♦ A large-core (62.5 micron) optical fiber through which multiple signals can propagate. Length constraint is 2 kilometers.

network ♦ An interconnection of multiple stations or systems that are able to send messages to and receive messages from one another.

network prefix ♦ First 13 bytes of an ATM End Station Address. Assigned by the switch during address registration. Used to route SVC signalling calls in the ATM network.

NIC (Network Interface Card) ♦ A component that connects a station to a network (for example, a LAN). Synonym: adapter.

NMS (Network Management Station) ♦ The system responsible for managing a network or a portion of a network. The NMS communicates to network management agents (an agent resides in each managed node) using a network management protocol.

NNI (Network-to-Network Interface) ♦ The interface between two pieces of equipment on a public network.

node ♦ A device, such as a station or concentrator, connected to the network media, usually with an adapter.

NRZI (Non-Return to Zero Inverted) ♦ A data transmission technique where a polarity transition from low to high, or high to low, represents a logical 1. The absence of a polarity transition represents a 0.

NSAP (Network Services Access Point) ♦ In the OSI environment it is the SAP between the network and the transport layers. It identifies a Data Terminal Equipment by a unique address.

OAM (Operations and Maintenance) ♦ Set of administrative and supervisory actions regarding network performance monitoring, failure detection, and system protection.

OAM cell ♦ A cell that contains ATM layer management information. It does not form a part of the upper layer information transfer. Generated by hardware or network administrators. Cell header bits distinguish OAM cells from normal data cells.

OC-3c (Optical Carrier level 3, concatenated) ♦ An optical signal defined with a base rate of 155.52 Mbps. The concatenated signal is indivisible, that is, it cannot be multiplexed and demultiplexed.

OSI (Open Systems Interconnection) Model ♦ The 7-layer protocol model defined by the ISO for data communications.

packet ♦ Data in a highly-structured format for the purpose of transmission. *Frame*, *packet*, and *PDU* are equivalent in most contexts.

packet buffer ♦ Memory used on the Interphase NIC to store data for fragmentation and reassembly. Synonym: Side RAM.

packet switching ♦ Statistical, connectionless switching based on information contained in variable-length packets.

payload ♦ Part of the ATM cell, it contains the actual information to be carried, and may also contain overhead. It occupies 48 bytes.

PCI (Peripheral Component Interconnect) bus ♦ A high-performance multiplexed address and data bus. Supporting 32-bit with optional 64-bit data transfers, the PCI bus is intended to be an interconnect between peripheral controllers, peripheral add-in boards, and processor/memory systems. The PCI bus operates at up to 66 MHz, providing burst transfer rates up to 264 MBps 32 bits wide, or up to 528 MBps 64 bits wide.

PDU (Protocol Data Unit) ♦ Data in a highly-structured format for the purpose of transmission. *Frame*, *packet*, and *PDU* are equivalent in most contexts.

PHY (Physical Layer) ♦ Layer 1 of the OSI model. Defines and handles the electrical and physical connections between systems. The Physical layer can also encode data in a form that is compatible with the medium (coaxial, twisted pair, fiber, and so on).

PING (Packet Internet Groper) ♦ An Internet protocol facility used to test the reachability of destinations by sending an ICMP echo request, and waiting for a reply.

PMC (PCI Mezzanine Card) ♦ A daughtercard form factor implementation of the PCI bus specification.

Glossary

PMD (PHY Medium Dependent) ♦ A standard that defines the medium and protocols to transfer symbols between PHYs.

point-to-multipoint connection ♦ A unidirectional, one-to-many VC that allows one station to simultaneously send data to the connected end stations.

point-to-point connection ♦ A bidirectional VC between two end points.

primitive ♦ Data and events passed between a layer service user and a layer service provider.

protocol ♦ A set of rules and conventions that govern the exchange of information between communicating parties.

PVC (Permanent/Provisioned Virtual Connection) ♦ A VC provisioned for indefinite use in an ATM network, established by the network management system (NMS). See also *SVC (Switched Virtual Circuit)* on page 172.

Q.93B ♦ Early draft of the signalling specification now known as Q.2931, on which UNI 3.0 was based.

Q.2110 ♦ ITU's *B-ISDN ATM Adaptation Layer- Service Specific Connection Oriented Protocol*, which is the protocol used to reliably transport signalling PDUs over a point-to-point link (such as between an end station and a switch).

Q.2931 ♦ ITU Recommendation derived from both Q.931 and Q.933 to provide SVC specifications and standards.

QoS (Quality of Service) ♦ The set of ATM performance parameters that characterize the traffic over a given VC.

QoS classes ♦ Five service classes defined by the ATM Forum in terms of the QoS parameters.

Q.SAAL (Signalling ATM Adaptation Layer) ♦ Original ITU draft of the specification of signalling's lower level service interface and transport protocol. Q.SAAL is now technically defined as *Q.2110*, but is still used to refer to this protocol layer.

reassembly ♦ The portion of the ATM SAR that reassembles an incoming multiplexed stream of ATM cells into packets.

RFC (Request for Comment) ♦ IETF documents that contain proposed standards and specifications. RFCs can be either approved, or simply archived as historical recommendations.

RFC-1577 ♦ IETF standard for running Layer 3 IP traffic directly over ATM. See also *CLIP (Classical IP)* on page 164.

RJ-45 connector ♦ Standard 8-wire connector for IEEE 802.3 networks and some telephone applications.

SAAL (Signalling AAL) ♦ Service-specific parts of the AAL protocol responsible for signalling. Its specifications, being developed by the ITU, were adopted from N-ISDN.

SAP (Service Access Point) ♦ Functional interface between the layers in the OSI model through which lower layers provide services to the higher layers along with PDUs.

SAR (Segmentation and Reassembly) ♦ The lower half of the AAL. The segmentation portion inserts data from packets into cells, adds any necessary header or trailer bits to the data, and passes the 48-octet payload to the ATM layer. Each AAL type has its own SAR format. At the destination, the reassembly portion extracts the cell payload and rebuilds the packet.

SAR-PDU ♦ The 48-octet PDU that the SAR sublayer exchanges with the ATM layer. It is comprised of the SAR-PDU payload and any control information that the SAR sublayer adds.

SC (Subscriber Connector) ♦ A connector where the transmit and receive fibers are one keyed module plug that latches.

SDH (Synchronous Digital Hierarchy) ♦ A hierarchy that designates signal interfaces for very high-speed digital transmission over optical fiber links. See also *SONET (Synchronous Optical Network)* on page 172.

SDU (Service Data Unit) ♦ User data passed through a SAP between the layers of the OSI or a similar model.

signalling ♦ An ATM connection procedure that dynamically implements explicit routes through switches to establish a communication link with another station on the network.

single-mode fiber ♦ A small-core (9 micron) optical fiber through which only one signal can propagate. Length constraint for the device used in Interphase products is 20 kilometers.

SLIP (Serial Line Internet Protocol) ♦ A protocol for transmitting and receiving IP datagrams via a serial interface.

SNMP (Simple Network Management Protocol) ♦ A high-level, standards-based protocol for network management, usually used in TCP/IP networks. An SNMP manager controls and measures the activities of SNMP agents that are embedded in nodes and network devices on the network. SNMP relies on MIBs embedded in the network resources to monitor and control the network.

Glossary

SONET (Synchronous Optical Network) ♦ An ANSI-defined standard for high-speed and high-quality digital optical transmission. It has been recognized as the North American standard for SDH.

SSCF (Service Specific Coordination Function) ♦ Part of the SSCS portion of the SAAL. Among other functions, it provides a clear interface for relaying user data and providing independence from the underlying sublayers. See also *SSCOP (Service Specific Connection-Oriented Protocol)* on page 172.

SSCOP (Service Specific Connection-Oriented Protocol) ♦ Part of the SSCS portion of the SAAL. SSCOP is an end-to-end protocol that provides error detection and correction by retransmission and status reporting between the sender and the receiver. It also guarantees delivery integrity. See also *SSCF (Service Specific Coordination Function)* on page 172.

SSCS (Service Specific Convergence Sublayer) ♦ One of the two components of the Convergence Sublayer (CS) of the AAL. It supports the specific requirements of upper-layer protocols.

ST (Straight Through) connector ♦ A connector where the transmit and receive fibers have separate twist-on connections.

station ♦ An addressable node on the network capable of transmitting and receiving data.

STM (Synchronous Transfer Mode) ♦ A packet-switching approach where time is divided into time slots assigned to single channels during which users can transmit periodically. Basically, time slots denote allocated (fixed) parts of the total available bandwidth.

STM-1 (Synchronous Transport Module-1) ♦ An ITU-defined SDH physical interface for ATM digital transmission at the rate of 155.52 Mbps.

STM-n (Synchronous Transport Module-n) ♦ An ITU-defined SDH physical interface for ATM digital transmission at n times the basic STM-1 rate. STM-n and SONET STS-3n transmission rates are equivalent.

STS (Synchronous Transport Signal)

subnet address ♦ An extension of the Internet addressing scheme. Using this method, a site can use a single Internet address for multiple physical networks.

SVC (Switched Virtual Circuit) ♦ A software-created dynamic connection between two network nodes. SVCs are created “on demand” and torn down upon completion of the data transfer.

symbol ♦ The smallest signaling element used by the MAC sublayer. The symbol set consists of sixteen data symbols and sixteen nondata symbols. Each symbol corresponds to a specific sequence of code bits (code group) to be transmitted by the PHY.

synchronous transmission ♦ A data transmission scheme where the interval between transmitted characters is fixed so that start and stop bits are not required. As opposed to asynchronous transmissions, synchronous transmissions are guaranteed a specific percentage of bandwidth on the network medium.

TCP/IP (Transmission Control Protocol/Internet Protocol) ♦ A set of communications protocols that define how different types of computers talk to each other. It is the standard architecture for internetworking multiple organizations, and the common link that ties the huge Internet together.

TELNET ♦ A TCP/IP protocol that supports remote terminal operations via a network.

Token Ring ♦ A 4 Mbps or 16 Mbps network that uses a ring topology and a token-passing access method.

UBR (Unspecified Bit Rate) ♦ With UBR, the source specifies no traffic parameters, and therefore the network does not guarantee transmission quality.

UNI (User-Network Interface) ♦ Definition of the interface between an end system and an ATM switch. Defines a set of specifications for signaling. Produced by the ATM Forum.

UNI 3.0 ♦ ATM Forum UNI specification for the physical (PHY) and ATM layers, the ILMI, OAM (traffic control), and PVC support.

UNI 3.1 ♦ A corrected version of UNI 3.0, this specification also includes SSCOP standards.

UNI 4.0 ♦ This UNI specification covers signalling issues in ABR and VP, as well as QoS negotiation.

UTP (Unshielded Twisted Pair) ♦ Type 3 cable with one or more twisted pairs where the wiring is not protected from electromagnetic and radio frequency interferences. There are two main categories of UTP used in ATM: category 3 for 25 Mbps, and category 5 for 155 Mbps. See also *CAT-3 (Category 3 UTP)* on page 163 and *CAT-5 (Category 5 UTP)* on page 163.

VBR (Variable Bit Rate) ♦ The bit rate available to a user for the transfer of user information that requires a guaranteed service for a bounded variable transmission rate.

Glossary

VBR-RT (Variable Bit Rate—Real Time) ♦ One of the service types for transmitting traffic which is timing- and control-dependent and is characterized by having both average and peak cell rates. VBR-RT is suitable for carrying traffic such as packetized (compressed) video and audio.

VBR-NRT (Variable Bit Rate—Non-Real Time) ♦ One of the service types for transmitting traffic which is not timing-critical and is characterized by having both average and peak cell rates. VBR-NRT is well-suited to long data packet transfers.

VC (Virtual Channel/Connection/Circuit) ♦ A logical transmission path or connection between two network endpoints.

VCI (VC Identifier) ♦ A 16-bit identifier in an ATM cell header which, when combined with the VPI, identifies the VC to the next ATM device.

VLAN (Virtual LAN) ♦ A networking environment where users on physically independent LANs are interconnected in such a way that it appears they are in the same LAN workgroup.

VP (Virtual Path) ♦ A logical pipe which can contain a group of VCs that connect network devices.

VPI (VP Identifier) ♦ A field in an ATM cell header which, when combined with the VCI, identifies the VC to the next ATM device.

WAN (Wide Area Network) ♦ A network spanning a large geographical area that provides communications among devices on a regional, national, or international basis.

workstation ♦ A networked computer typically reserved for end-user applications.

Index

When using this index, keep in mind that a page number indicates only where referenced material begins. It may extend to the page or pages following the page referenced.

A

AAL service classes 140
 AAL sublayers..... 142
 AAL5 segmentation process..... 143
 AAL5 statistics 85, 116
 adapter
 configuration 29, 87
 configuration overview 35, 93
 configuration requirements..... 30, 88
 driver installation
 NetWare 65
 faceplate configuration 11
 installation to motherboard..... 9
 interrupt pin 126
 LED diagnostics 117
 multiple adapters
 NetWare 82
 Windows NT 17, 24
 network connections 10
 specifications..... 125
 address registration 38, 144
 AIX driver 3
 API field, debugging 64
 application settings, CellView..... 60
 ARP protocol, NetWare..... 77
 ARP server 46, 47, 102, 157, 158
 ASIG file, NetWare..... 78
 ATM
 cell diagram 137
 LAN Emulation 146
 layers 138
 network diagram 146
 network topology diagram 133
 scalability 138

standards compliance 125
 switch..... 135, 136
 switch requirements 5
 technology overview 133
 ATM Adaptation layer (AAL) 140
 ATM address, defined 31, 88
 ATM End Station Address (AESAs)..... 144
 ATM Layer 140
 ATM Physical layer 139
 autoexec.ncf file, NetWare
 command formats..... 75
 editing..... 74
 IP over ATM client 80
 MTU size 78
 multiple adapters 82
 signalling setup..... 80
 startup commands 78
 TCP/IP stack 78

B

BIND IP command, NetWare..... 77
BIND IPX command, NetWare..... 76
 bootup problems 119
 bridged protocols 155
 Broadcast field, PVC 45, 102
 broadcast/unknown server (BUS)..... 150
 buffer sizes, adapter 125

C

caution
 maximum packet size, NetWare..... 73
 mixing frame types, NetWare..... 69
 removing driver 15, 21, 67
 wiring connectors 130
 cell header 135

- cell switching 134
- cells 134
- CellView
- adapter configuration29, 87
 - add ELAN clients to LES 57
 - configuration overview35, 93
 - Connections dialog 62
 - controlling application display 60
 - Debugging dialog..... 63
 - debugging messages 63
 - debugging options 121
 - display signalling connections..... 61
 - features.....29, 87
 - Global routines 59
 - IP over ATM setup 45, 102, 104
 - LEC setup39, 94
 - LECS setup50, 108
 - LES setup52, 110
 - main dialog33, 90
 - Setup routines35, 91
 - signalling setup..... 36
 - startup32, 89
 - Statistics routines59, 114
 - verify installation84, 115
- channel configuration, NetWare..... 70
- client mappings for LES 56
- commands, NetWare
- BIND IP* (format) 77
 - BIND IPX* (format) 76
 - LOAD* (format) 75
 - LOAD ASIG* 78
 - LOAD CVCONF* 78
 - LOAD INSTALL* 67
 - LOAD TCPIP* 78, 81, 83
- compliance
- ATM standards 125
 - FCC..... 125
 - IEEE 125
 - network interface 125
 - PCI bus..... 125
- configuring drivers
- IP over ATM.....45, 102
 - LEC39, 94
 - LECS50, 108
 - LES52, 110
 - overview of tasks35, 93
 - PVCs for IP over ATM clients 48, 105
 - PVCs for LECs.....43, 99
 - requirements 30, 88
 - UNI signalling..... 36, 80
- Connections dialog62
- connectors and cables
- options10
 - RJ-45 pin assignments130
 - RJ-45 to adapter11
 - SC Duplex to adapter11
 - specifications127
 - UTP wiring diagrams129
- Convergence Sublayer (CS).....142
- CSMA/CD protocol.....146
- cvconf* file78
- D**
- data rates for adapters 1, 125
 - Debugging dialog63
 - debugging options, CellView121
 - Default ELAN Type field52, 110
 - default gateway 19, 25
 - Default MTU Sizes field..... 52, 110
 - dimensions of adapter126
 - DMA burst rate125
 - drivers available3
- E**
- EEPROM size, adapter125
 - ELAN client mappings for LES56
 - ELAN MTU Size field..... 42, 55, 98, 113
 - ELAN Name field41, 55, 97, 112
 - ELAN services.....50, 52, 108, 110
 - ELAN Type field.....41, 55, 97, 113
 - Enable Address Registration field38
 - Enable Advanced Settings field61
 - Enable IP over ATM field47, 104
 - Enable LEC field41, 96
 - Enable LECS field51, 109

Enable LES field	55, 112	installation	
encapsulation	154	adapter hardware	7
Encapsulation field, PVC45, 49, 101, 107		electrical warning	8
End Pts on a Pt-Mpt field	62	inserting adapter in motherboard	9
end station identifier (ESI)	144	network connections	10
environment specifications	126	RJ-45 connections	11
ESI	144	SC Duplex connections	11
ESI/Selector field	47, 104	interrupt pin, adapter	126
ESI/Selector value	31, 89	IP address	
expansion slot, motherboard	9	ARP server	47, 104
F		IP over ATM client	47, 104
faceplate configuration	11	NetWare Server	71, 77
FCC compliance	125	PVC table	49, 107
fiber connections		Windows NT	19, 25
adapter	11	IP mask, NetWare driver	71, 77
data rates	125	IP over ATM	
specifications	127	1577 dialog	46
fixed-length cells	137	applications	158
G		ARP server	47, 104
global settings for CellView	59	client Interface	157
green (link) LED	125	enable	47, 104
H		initialize	17, 80
hardware		IP Address field	47, 104
adapter faceplate	11	network configuration	155
adapter installation	7	protocol stack	156
ATM switch requirements	5	PVC Only field	47, 104
electrical warning	8	PVC setup	48, 105
inserting adapter in motherboard	9	setup	45, 102
network connections	10	Subnet Mask field	47, 104
RJ-45 connections	11	verify	85, 116
SC Duplex connections	11	IP to ATM address mappings	158
header, ATM cell	135	IRIX driver	3
height/length of adapter	126	L	
host-bus interface	125	L3MTU Size field	42
I		LAN Emulation	
IEEE compliance	125	(LANE) tutorial	145
ILMI field, debugging	64	protocol phases	151
ILMI Port Change Detection field	38	protocol stack	147
ILMI tutorial	144	protocol support	145
INSTALL utility, NetWare	67, 86	services	148
		LANE client (LEC)	
		description	148

- ELAN MTU Size field.....42, 98
 ELAN Name field.....41, 97
 ELAN Type field41, 97
 enable41, 96
 initialize17, 23
 L3MTU Size field.....42
 LECS/LES ATM Address field 42, 98
 MAC Address field.....41, 96
 MTU size42, 78, 98
 PVC Only field.....41, 96
 PVC setup.....43, 99
 setup.....39, 94
 verify85, 116
- LANE configuration server (LECS)
 description149
 dialog.....51
 enable51, 109
 setup.....50, 108
 well known address109
- LANE server (LES)
 client mappings56
 description149
 dialog.....54
 enable55, 112
 setup.....52, 110
- LECS/LES ATM Address field.....42, 98
- LED
 diagnostics.....117, 118
 faceplate configuration11
 specification125
 troubleshooting118
- legacy LAN protocol147
 length/height of adapter.....126
 link (yellow) LED118, 125
 LLC encapsulation154
 LLC_Snap, PVC.....45, 49, 101, 107
 LOAD command (format).....75
 LOAD INSTALL command.....67
 LOAD TCPIP command78, 81, 83
 Logical IP Subnetwork (LIS).....157
- M**
 MAC address
 adapter.....31, 89
 LEC41, 96
 PVC table44, 101
 maximum packet size, NetWare.....73, 98
 mechanical specs for adapter126
 memory, adapter.....125
 motherboard expansion slots.....9
 MTU size42, 52, 55, 98, 110, 113, 158
 MTU size, *autoexec.ncf* file78
 multiple adapters
 NetWare Server.....82
 Windows NT17, 24
 multiprotocol encapsulation, AAL5 ...154
- N**
 NetWare Server
autoexec.ncf file74
 CellView utility87
 commands
 BIND IP (format)77
 BIND IPX (format).....76
 LOAD (format).....75
 LOAD ASIG78
 LOAD CVCONF78
 LOAD INSTALL.....67
 LOAD TCPIP78, 81, 83
 driver installation67
 driver overview65
 driver removal85
 endstation requirements.....66
 initializing clients72
 INSTALL utility67
 IP over ATM client80, 102
 maximum packet size.....73
 MTU size.....78, 98
 multiple adapters.....82
 network number71
 parameter configuration70
 protocol configuration70
 selecting a driver69, 72
 startup commands78
 UNI signalling80
 network address, defined31, 88

network connections	
adapter	10
specifications	127
network interface	19, 25, 125
network number, NetWare	71
Network Prefix field	38, 47, 104
network prefix, defined	31, 89, 144
network problems	121
Null encapsulation	154
Null encapsulation, PVC	45, 49, 101, 107
O	
operating power requirements	126
OS/2 driver	3
OSI Model	139
output link (VPI/VCI)	136
P	
parameter configuration, NetWare	70
PCI	
adapter installation	8
compliance	125
expansion slot	9
overview	131
permanent ELAN clients, LES	56
permanent virtual circuits (PVCs)	136
pin assignments, RJ-45 connector	130
PMD sublayer	139
power requirements for adapter	126
primary WINS server, Windows NT	19
protocol configuration, NetWare	70
protocol frame classes	154
protocol model for AAL sublayers	142
Pt-to-Mpt field	62
Pt-to-Pt field	62
PVC	
broadcast setting, LEC	45, 102
Settings dialog	44, 49
setup	43, 48, 105
table	43, 99
PVC Only field	41, 47, 96, 104
R	
Register Nonstandard Prefixes field	38
removing drivers	
NetWare Server	85
Windows NT	20, 26
RJ-45 connections	10, 11, 127
pin assignments	130
ROM expansion, adapter	125
routed protocols	155
RX/TX connections	
fiber	11
RJ-45 pin assignments	130
S	
SAR sublayer	142
SC Duplex connections	10, 11, 127
scalability	138
SCO driver	3
SDH	144
secondary WINS server	19
selecting a driver	
NetWare Server	69, 72
Windows NT	16, 21
selector value, defined	31, 89
Set Table Font field, CellView	61
signalling	
ATM switch requirements	5
connections display	61
debugging	64
restart	39
setup	36, 80
statistics	84, 116
size of adapter	126
SMT/Token Management protocol	146
software available	3
software drivers	
installation	
NetWare Server	67
Windows NT 3.51	15
Windows NT 4.0	21
overview	3
removal	
NetWare Server	85
Windows NT	20, 26
selecting a driver	

NetWare Server.....	69, 72	adapter.....	11
Windows NT	16, 21	data rates.....	125
Solaris driver	3	specifications	127
SONET	144	wiring diagrams	129
SONET/SDH compliance.....	125	V	
specifications, adapter	125	VC Based Multiplexing	154
SRAM size.....	125	VCI field	
startup commands, NetWare	78	PVC	45, 49, 101, 107
<i>startup.ncf</i> file, NetWare.....	73	signalling.....	38
Stat Refresh Rate field.....	61	virtual circuit connection (VCC).....	134
statistics, CellView	59, 114	virtual circuit diagram	135
status (green) LED	118, 125	virtual circuit identifier (VCI)	135
Strict		virtual circuits (VCs).....	134
ELAN Name field.....	55, 113	virtual path (VP).....	135
MTU Size field.....	55, 113	VPI field, signalling.....	37
subnet mask	19, 25, 71, 77	W	
Subnet Mask field.....	47, 104	warning, electrical shock	8
SVC Range field.....	37	Well Known Address field.....	52, 109
switch, ATM.....	135, 136	Windows NT	
switch, signalling requirements	5	driver removal	20, 26
switched virtual circuits (SVCs).....	136	endstation requirements.....	14
system memory required		Network Settings dialog	17
NetWare	66	selecting a driver.....	16, 21
Windows NT.....	15	Y	
T		yellow (status) LED.....	125
TC sublayer	139		
TCP/IP			
<i>autoexec.ncf</i> file, NetWare	78		
NetWare Server	71, 77		
Windows NT.....	18, 24		
temporary ELAN clients, LES.....	56		
troubleshooting			
bootup problems.....	119		
LEDs.....	118		
network problems	121		
U			
UNI Revision field.....	37		
UNI signalling requirements	5		
UNI signalling setup.....	36, 80		
UnixWare driver	3		
UTP connections			

Warranty Product Registration Card

Registered Interphase PCI ATM adapters have a lifetime warranty when used in accordance with this user's guide.

Any Interphase PCI ATM adapter which is defective in workmanship or materials will be repaired or replaced with a functionally equivalent adapter, at Interphase's option, for as long as the adapter is used in the computer where it was originally installed. These warranties apply to end users only (not OEMs, VARs, or distributors) and do not include upgrades. The end user must call Interphase to obtain an RMA number and return the nonconforming adapter to Interphase freight prepaid.

To activate this warranty, the end user must complete and return this registration card to Interphase within 30 days of the purchase date. Your registration will also enable Interphase to notify you about software updates and product enhancements.

INTERPHASE'S SOLE LIABILITY AND END USER'S SOLE REMEDY FOR BREACH OF THESE WARRANTIES IS THE REPAIR OR REPLACEMENT OF THE NONCONFORMING ADAPTERS. THESE WARRANTIES ARE EXCLUSIVE AND REPLACE ALL OTHER WARRANTIES, EXPRESS OR IMPLIED, INCLUDING WARRANTIES OF MERCHANTABILITY AND FITNESS FOR A PARTICULAR PURPOSE.

Name _____ Title _____

Company Name _____

Company Address _____

City _____ Province _____

State _____ Zip _____ Country _____

Telephone () _____ Fax () _____

E-mail Address _____

Which product did you purchase? _____

Serial Number _____

Where did you purchase this product (company name)? _____

Date Purchased _____

Number of client nodes at this site: _____

Operating System(s) being used with this product:

- Solaris SunOS AIX NetWare
- HP-UX IRIX Mac OS Windows NT
- PC NFS DEC Ultrix Other _____

Operating System Version: _____

Network Protocol(s) in use:

- TCP/IP IPX AppleTalk Other _____

We welcome your comments, ideas, and suggestions. You can fax additional comments to 214/654-5500, or send them to intouch@iphase.com

If you would like information on other Interphase products, please check the appropriate boxes:

- ATM FDDI SCSI Fibre Channel 100 BaseT

If you are mailing this card from outside the United States, please add postage.

11/96

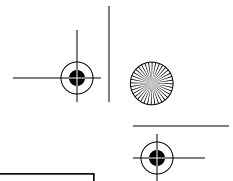
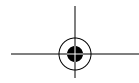
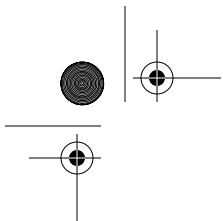

NO POSTAGE
NECESSARY
IF MAILED
IN THE
UNITED STATES

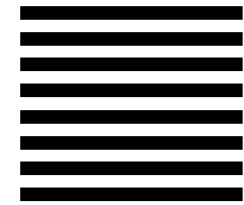

5575.h Page 182 Friday, December 12, 1997 6:37 PM

BUSINESS REPLY MAIL
FIRST-CLASS MAIL PERMIT NO. 5784 DALLAS TEXAS

POSTAGE WILL BE PAID BY ADDRESSEE



ATTN: WARRANTY DEPARTMENT
INTERPHASE CORPORATION
13800 SENLAC DR
DALLAS TX 75234-9600

