



***i*SPAN[®] 6575 CompactPCI[®] ATM Adapter Users Guide**

Document No. UG06575-10-00-C00

Release Date: December 2003



NOTE

See Appendix **C** for Regulatory Statements/Conditions that affect the operation of this product.

The CE Declaration of Conformity can be found at www.interphase.com

Copyright Notice

© 2002, 2003 by Interphase Corporation. All rights reserved.

Printed in the United States of America, 2003.

This manual is licensed by Interphase to the user for internal use only and is protected by copyright. The user is authorized to download and print a copy of this manual if the user has purchased one or more of the Interphase adapters described herein. All copies of this manual shall include the copyright notice contained herein. No part of this manual, whether modified or not, may be incorporated into user's documentation without prior written approval of

Interphase Corporation
Parkway Centre 1
2901 North Dallas Parkway, Suite 200
Dallas, Texas 75093

Phone: (214) 654-5000
Fax: (214) 654-5500

Disclaimer

Information in this manual supersedes any preliminary specifications, preliminary data sheets, and prior versions of this manual. While every effort has been made to ensure the accuracy of this manual, Interphase Corporation assumes no liability resulting from omissions, or from the use of information obtained from this manual. Interphase Corporation reserves the right to revise this manual without obligation to notify any person of such revision. Information available after the printing of this manual will be in one or more Read Me First documents. Each product shipment includes all current Read Me First documents. All current Read Me First documents are also available on our web site.

THIS MANUAL IS PROVIDED "AS IS." INTERPHASE DISCLAIMS ALL WARRANTIES, EXPRESS OR IMPLIED, INCLUDING THOSE OF MERCHANTABILITY AND FITNESS FOR A PARTICULAR PURPOSE OR ARISING FROM A COURSE OF DEALING, USAGE, OR TRADE PRACTICE.

IN NO EVENT SHALL INTERPHASE BE LIABLE FOR ANY INDIRECT, SPECIAL, CONSEQUENTIAL, OR INCIDENTAL DAMAGES, INCLUDING, WITHOUT LIMITATION, LOST PROFITS OR LOSS OR DAMAGE TO DATA ARISING OUT OF THE USE OR INABILITY TO USE THIS MANUAL, EVEN IF ADVISED OF THE POSSIBILITY OF SUCH DAMAGES.

Trademark Acknowledgments

Interphase[®], FibreView[®], iWARE[®], iSPAN[®], iNAV[®], and the Interphase logo are registered trademarks, (i)chip[™], SynWatch[™], ENTIA[™], PowerSAN[™], and SlotOptimizer[™] are trademarks of Interphase Corporation.

All other trademarks are the property of their respective manufacturers.

Assistance

Product Purchased from Reseller

Contact the reseller or distributor if

- You need ordering, service or any technical assistance.
- You received a damaged, incomplete or incorrect product.

Product Purchased Directly from Interphase Corporation

Contact Interphase Corporation directly for assistance with this, or any other Interphase Corporation product. Please have your purchase order and serial numbers ready.

Customer Service

United States: Telephone: (214) 654-5666
Fax: (214) 654-5624
E-Mail: intouch@iphase.com

Europe: Telephone: + 33 (0) 1 41 15 44 00
Fax: + 33 (0) 1 41 15 12 13

World Wide Web

<http://www.interphase.com>

END-USER LICENSE AGREEMENT FOR INTERPHASE CORPORATION SOFTWARE

IMPORTANT NOTICE TO USER—READ CAREFULLY

THIS END-USER LICENSE AGREEMENT FOR INTERPHASE CORPORATION SOFTWARE (“AGREEMENT”) IS A LEGAL AGREEMENT BETWEEN YOU (EITHER AN INDIVIDUAL OR SINGLE ENTITY) AND INTERPHASE CORPORATION FOR THE SOFTWARE PRODUCTS ENCLOSED HEREIN WHICH INCLUDES COMPUTER SOFTWARE AND PRINTED MATERIALS (“SOFTWARE”). BY INSTALLING, COPYING, OR OTHERWISE USING THE ENCLOSED SOFTWARE, YOU AGREE TO BE BOUND BY THE TERMS OF THIS AGREEMENT. IF YOU DO NOT AGREE TO THE TERMS AND CONDITIONS OF THIS AGREEMENT, PROMPTLY RETURN, WITHIN THIRTY DAYS, THE UNUSED SOFTWARE TO THE PLACE FROM WHICH YOU OBTAINED IT FOR A FULL REFUND.

The Software is protected by copyright laws and international copyright treaties, as well as other intellectual property laws and treaties. The Software is licensed, not sold.

Grant of License: You are granted a personal license to install and use the Software on a single computer solely for internal use and to make one copy of the Software in machine readable form solely for backup purposes.

Restrictions on Use: You may not reverse engineer, decompile, or disassemble the Software. You may not distribute copies of the Software to others or electronically transfer the Software from one computer to another over a network. You may not use the Software from multiple locations of a multi-user or networked system at any time. You may not use this software on any product for which it was not intended. You may not use this software on any non-Interphase product. LICENSEE MAY NOT RENT, LEASE, LOAN, OR RESELL THE SOFTWARE OR ANY PART THEREOF.

Ownership of Software: Interphase or its vendors retain all title to the Software, and all copies thereof, and no title to the Software, or any intellectual property in the Software, is being transferred.

Software Transfer: You may permanently transfer all of your rights under this Agreement, provided you retain no copies, you transfer all the Software, and the recipient agrees to the terms of this Agreement.

Limited Warranty: Interphase Corporation (“Seller”) warrants that (i) the hardware provided to Buyer (“Products”) shall, at the F.O.B. point, be free from defects in materials and workmanship for a period of one (1) year from the date of shipment to Buyer; (ii) the software and/or firmware associated with or embedded in the Products shall comply with the applicable specifications for a period of six (6) months from the date of shipment to Buyer; and (iii) its services will, when performed, be of good quality. Defective and nonconforming Products and software must be held for Seller’s inspection and returned at Seller’s request, freight prepaid, to the original F.O.B. point.

Upon Buyer’s submission of a claim in accordance with Seller’s Return and Repair Policy, Seller will, at its option either (i) repair or replace the nonconforming Product; (ii) correct or replace the software/firmware; (iii) rework the nonconforming services; or (iv) refund an equitable portion of the purchase price attributable to such nonconforming Products, software, or services. Seller shall not be liable for the cost of removal or installation of products or any unauthorized warranty work, nor shall Seller be responsible for any transportation costs, unless expressly authorized in writing by Seller. This warranty does not cover damage to the Product resulting from accident, disaster, misuse, negligence, improper maintenance, or modification or repair of the Product other than by Seller. Any Products or software replaced by Seller will become the property of Seller.

REMEDIES AND EXCLUSIONS. THE SOLE LIABILITY OF SELLER AND BUYER’S SOLE REMEDY FOR BREACH OF THESE WARRANTIES SHALL BE LIMITED TO REPAIR OR REPLACEMENT OF THE PRODUCTS OR CORRECTION OF THAT PART OF THE SOFTWARE, WHICH FAILS TO CONFORM TO THESE WARRANTIES. EXCEPT AS EXPRESSLY STATED HEREIN, AND EXCEPT AS TO TITLE, THERE ARE NO OTHER WARRANTIES, EXPRESS OR IMPLIED, INCLUDING WARRANTIES OF MERCHANTABILITY OR FITNESS FOR ANY PARTICULAR PURPOSE, IN CONNECTION WITH OR ARISING OUT OF ANY PRODUCT OR SOFTWARE PROVIDED TO BUYER.

IN NO EVENT SHALL SELLER HAVE ANY LIABILITY FOR INDIRECT, INCIDENTAL, SPECIAL OR CONSEQUENTIAL DAMAGES, HOWEVER CAUSED AND ON ANY THEORY OF LIABILITY, ARISING OUT OF THESE WARRANTIES, INCLUDING BUT NOT LIMITED TO LOSS OF ANTICIPATED PROFITS, LOSS OF DATA, USE OR GOODWILL, EVEN IF ADVISED OF THE POSSIBILITY OF SUCH DAMAGES. (IC-199, 1/97)

Limitation of Liability: NEITHER INTERPHASE NOR ITS LICENSORS SHALL BE LIABLE FOR ANY GENERAL, INDIRECT, CONSEQUENTIAL, INCIDENTAL, OR OTHER DAMAGES ARISING OUT OF THIS AGREEMENT EVEN IF ADVISED OF THE POSSIBILITY OF SUCH DAMAGES.

Confidentiality: The Software is copyrighted and contains proprietary and confidential trade secret information of Interphase and its vendors. Licensee agrees to maintain the Software in confidence and not to disclose the Software to any third party without the express written consent of Interphase. Licensee further agrees to take all reasonable precautions to prevent access to the Software by unauthorized persons.

Termination: Without prejudice to any other rights, Interphase may terminate this Agreement if you fail to comply with any term or condition of the Agreement. In such event you must destroy the Software together with all copies, updates, or modifications thereof.

Export: You agree to comply with all export and re-export restrictions and regulations of the U.S. Department of Commerce or other applicable U.S. agency. You must not transfer the Software to a prohibited country or otherwise violate any such restrictions or regulations.

U.S. Government Restricted Rights: Use, duplication, or disclosure of the Software to or by the U.S. Government is subject to restrictions as set forth in the applicable U.S. federal procurement regulations covering commercial/restricted rights software. You are responsible for complying with the notice requirements contained in such regulations.

General: You acknowledge that you have read and understand this Agreement, and by installing and using the Software you agree to be bound by the terms and conditions herein. You further agree that this is the complete and exclusive Agreement between Interphase and yourself. No variation of the terms of this Agreement or any different terms will be enforceable against Interphase unless agreed to in writing by Interphase and yourself. The validity of this Agreement and the rights, obligations, and relations of the parties hereunder shall be determined under the substantive laws of the State of Texas. If any provision of this Agreement is held invalid, illegal, or unenforceable, the remaining provisions shall in no way be affected or impaired thereby. All rights in the Software not specifically granted in this Agreement are reserved by Interphase.

Contents

Using This Guide	vii
Purpose.....	vii
Audience.....	vii
Icon Conventions.....	vii
Text Conventions.....	viii
Documentation Updates.....	viii
Driver Updates.....	ix
CHAPTER 1 Introduction	
Adapter Overview.....	1
Product Features.....	1
Software Drivers.....	1
Minimum System Requirements.....	3
Windows NT.....	3
Solaris.....	3
HP-UX.....	3
NetWare.....	4
CHAPTER 2 Installing the CompactPCI Adapter	
Overview.....	5
Verifying Minimum Requirements.....	5
Understanding Safety Precautions.....	5
Do Not Substitute Parts or Modify Equipment.....	6
Ground the Instrument.....	6
Do Not Operate in an Explosive Atmosphere.....	6
Keep away from Live Circuits.....	6
Observe Dangerous Procedure Warnings.....	6
Inspecting the Adapter.....	6
Installing the Adapter.....	7
Connecting to the Network.....	11
CHAPTER 3 Installing the Windows 2000 Driver	
Overview.....	15
Installation (A00 Driver).....	16
Installation (A02 Driver).....	16
Introduction.....	16
Create a Directory for the New Driver Files.....	16
Remove System Cache Entries for Default Driver.....	16
Driver Upgrade.....	17
Initialize Advanced Driver Parameters.....	18

VPI Information.....	19
VPI VC Information.....	19

CHAPTER 4 Installing the Windows NT Driver

Overview.....	21
Before You Start.....	21
Providing Redundant Link Support.....	22
Installing the Driver.....	22
Starting the Installation.....	23
Configuring Network Protocols.....	26
Completing the Driver Installation.....	27
Adding Clients after Driver Installation.....	28
Removing a Driver.....	28

CHAPTER 5 Installing the Solaris Driver

Overview.....	31
Before You Start.....	31
Providing Redundant Link Support.....	31
Installing the Driver.....	32
Adding Clients after Driver Installation.....	37
Removing the Driver.....	37
ATM AAL5 API Driver.....	38
Installation.....	39

CHAPTER 6 Installing the HP-UX Driver

Overview.....	41
Before You Start.....	41
Providing Redundant Link Support.....	42
Installing and Configuring the Driver.....	42
Starting the Installation.....	42
Configuring the Driver to the Network.....	44
Verifying the Installation.....	45
Configuring Clients Manually.....	45
Message Logging.....	46
Adding Clients after Driver Installation.....	46
Removing the Driver.....	47
SNMP Sub-Agent.....	47
Installation.....	47

CHAPTER 7 Installing the Linux Driver

Overview.....	49
Installing the Adapters in the System.....	49
Copy the Driver Source Code to the Kernel Source Directory.....	50

Rebuild Kernel with ATM Driver Support.....	50
Load the Adapter Hardware Driver (ia Driver) if it is Built as a Module.....	50
Ia Driver Configuration	50
Configuration of Adapter Buffers	50
Turn on ia Debug Trace	51
ATM Stack Configuration.....	51
Ia Driver Test Using ttcp_atm and PVC	52
UBR Test.....	52
ABR Test.....	52
CBR Test.....	52

CHAPTER 8 Using CellView for GUI Systems

Overview	53
CellView Features.....	53
Before You Start.....	54
ATM Address.....	54
Redundant Link Support.....	55
LES and LECS Functions.....	56
Starting CellView.....	56
CellView Adapter Interfaces and Actions	57
Setting Up ATM Network Services.....	59
Setting Up Physical Features	60
Setting Up UNI signaling	62
Setting Up LAN Emulation Clients	65
LEC and LECS/LES ATM Address Settings	66
SVC Default Settings	69
LEC PVC Settings	70
Adding or Modifying LEC PVC Entries	71
Deleting LEC PVC Entries.....	73
Setting Up a LAN Emulation Server.....	73
LES Network Settings.....	74
ELAN Client Mappings Settings.....	75
Adding a Client that is not Assigned to an ELAN.....	76
Inserting Clients Assigned to Another ELAN.....	76
Deleting a Client.....	77
Setting Up a LAN Emulation Configuration Server	77
Setting Up a CIP Client and Server	79
CIP Client and ARP Server Settings.....	80
CIP PVC Settings.....	81
Adding or Modifying CIP PVC Entries.....	82
Deleting CIP PVC Entries	83
Statistics Information.....	83
signaling Statistics.....	84
AAL5 Statistics.....	86
LEC Statistics.....	87
MPOA Statistics	90
General MPOA Statistics.....	91

MPOA Counters.....	93
LES Statistics.....	95
LECS Statistics.....	97
CIP Statistics.....	100
Global Settings.....	102
Controlling Application Display Settings.....	102
Displaying signaling Connections Settings.....	103
Producing Debugging Messages.....	104

CHAPTER 9 Installing the NetWare Driver

Overview.....	107
Before You Start.....	107
Providing Redundant Link Support.....	108
Installing the Novell Support Pack.....	108
Installing the NetWare Integrated (Fat) Driver.....	109
Starting the Installation.....	110
Configuring Protocols and Parameters.....	112
Loading the Driver.....	114
Configuring the System for 4K or 9K MTU Support.....	116
Editing the Boot Configuration File.....	116
Completing the Driver Installation.....	117
Adding Clients after Driver Installation.....	117
Removing a Driver.....	117
Installing the NetWare ODI (Thin) Driver.....	118
Installation.....	118
Configuration Options.....	118
Troubleshooting Tips.....	119

CHAPTER 10 Using CellView for NetWare Servers

Overview.....	121
CellView Features.....	121
Before You Start.....	122
ATM Address.....	123
Redundant Link Support.....	123
LES and LECS Functions.....	124
Starting CellView.....	124
Main CellView Information.....	125
CellView Keyboard Commands.....	126
Setting Up ATM Network Services.....	127
Setting Up Physical Features.....	128
Setting Up LAN Emulation Clients.....	130
Setting up LEC PVCs.....	134
Adding or Modifying LEC PVC Entries.....	135
Deleting LEC PVC Entries.....	137
Setting Up a LAN Emulation Server.....	138

Setting Up a LAN Emulation Configuration Server	139
Setting up a CIP Client and Server	141
Setting up CIP PVCs.....	142
Adding or Modifying CIP PVC Entries	143
Deleting CIP PVC Entries	145
Statistics Information.....	145
signaling Statistics.....	146
AAL5 Statistics.....	148
LEC Statistics.....	149
General LEC Information.....	149
LEC Client Connection Table (CCT) Statistics.....	151
MPOA Statistics	152
MPOA (MPS).....	153
MPOA (Ingress).....	155
MPOA (Egress).....	156
MPOA (VCC).....	158
MPOA Counters.....	159
CIP Statistics	160
General CIP Information	160
CIP Connection Table (CT) Information	162
LES Statistics	163
General LES Information	163
LES Client Service Table Statistics	164
LECS Statistics	165

CHAPTER 11 Troubleshooting

Overview	167
Interpreting LEDs.....	167
Problems and Possible Solutions	167
Link and Status Problems.....	168
Boot Problems.....	169
Network Problems.....	170

APPENDIX A Specifications

Specifications.....	177
---------------------	-----

APPENDIX B Cabling

Straight-Through Cable.....	179
Crossover Cable.....	179

APPENDIX C Regulatory Statements

FCC.....	181
Canadian	181
European.....	181

EN60950–IEC950 Safety Standard	182
Fiber Products’ Compliance, LASER.....	182
Usage Restrictions	182
Restrictions d'utilisation.....	182
Fiber Products’ Compliance, LED.....	183
Glossary	185
Index	193

Using This Guide

Purpose

This Users Guide provides information about the Interphase *iSPAN*[™] 6575 CompactPCI[®] ATM adapter. It describes general features, hardware and software installation procedures (with safety precautions), and the software modules that comprise the product. It also provides detailed information about the external software interface and about how the software modules interact.

Audience

This manual assumes that its audience has a general understanding of computing and networking terminology.

Icon Conventions

Icons draw your attention to especially important information:



NOTE

The Note icon indicates important points of interest related to the current subject.



CAUTION

The Caution icon brings to your attention those items or steps that, if not properly followed, could cause problems in your machine's configuration or operating system.



WARNING

The Warning icon alerts you to steps or procedures that could be hazardous to your health, cause permanent damage to the equipment, or impose unpredictable results on the surrounding environment.

Text Conventions

The following conventions are used in this manual. Computer-generated text is shown in typewriter font. Examples of computer-generated text are: program output (such as the screen display during the software installation procedure), commands, directory names, file names, variables, prompts, and sections of program code.

Computer-generated text example

Commands to be entered by the user are printed in **bold Courier** type. For example:

```
cd /usr/tmp
```

Pressing the return key (↵ **Return**) at the end of the command line entry is assumed, when not explicitly shown. For example:

```
/bin/su
```

is the same as:

```
/bin/su ↵ Return
```

Required user input, when mixed with program output, is printed in **bold Courier** type.

Documentation Updates

The latest documentation (in Adobe[®] Acrobat[®] pdf) for our current products are available on our WWW site. Interphase recommends our customers visit the web site to verify that they have the latest version of the documentation.

1. Access the following web page:
<http://www.iphase.com>
2. Move the mouse (or other pointer) and click on the **Products and Services** option. A menu will appear on the left side with **Telecom Solutions**, **Enterprise Solutions**, and **Services** options. Choose the appropriate menu item (such as **PowerSAN Fibre Channel HBAs**).
3. A new web page with a list of the currently offered products in that category will appear on the right side. Choose your product by clicking on the product number (i.e. 4532, 5540, 4575, etc.).
4. The Product Description page appears for the product selected. At the left side of the page is a list showing additional information web pages for that product. Choose the **User Guides** item.
5. A new web page appears with a list of the latest released user guides available for the product. Click on the document you require.
6. A form will open, which you are required to fill out to request Interphase documentation. Press the `submit` button on the bottom of the page after filling it out.

Driver Updates

Contact our Technical Support Department at swlib@iphase.com to determine if updated drivers are available for your product.

When contacting technical support, please be sure to provide your name, company name and address, phone number, product name, driver version (if applicable), OS and version (if applicable) and serial number. Providing this information will help speed up our response.

Adapter Overview

The *iSPAN*[®] 6575 adapter supports a data rate of 155 Mbps over fiber and copper. This adapter is a single-slot, half-size card that adheres to the CompactPCI[®] Specification 1.0. It is based on the Interphase (i)chip[™] SAR+ technology, which provides a full range of ATM network communications. It integrates the (i)chipSAR+, which includes hardware-based Available Bit Rate (ABR) support in compliance with the ATM Forum Traffic Management 4.0 specification.

The network connections available for the board are shown in the following table:

Interface	Connections
SONET OC-3c Fiber	SC Duplex, Multimode, Single mode
SONET UTP	UTP Cat 5

Product Features

- CompactPCI Draft 1.0 compliant
- 155 Mbps SONET OC-3c over single-mode or multimode fiber
- 155 Mbps SONET over UTP copper
- 128 K standard buffer memory, expandable to 1 MB
- AAL5 ATM Adaptation Layer
- Dual function memory management for Cell-FIFO or on-board packet reassembly
- Hardware-based Segmentation and Reassembly (SAR) functions
- LED displays for board status and network link
- 32-bit, zero wait-state PCI DMA master
- Up to 128-byte burst transfers

Software Drivers

The Interphase ATM adapter uses Interphase's Integrated Driver (ID 2.0), which complies with the ATM Forum LAN Emulation specification versions 1.0 and 2.0. The driver integrates support for various ATM network technologies. It provides standards-based support for LAN Emulation (LANE) networks, Multi-Protocol over ATM (MPOA), and Classical IP (CIP) networks. It provides broadcast/multicast addressing, allowing you to run legacy LAN (Ethernet, Token Ring, and FDDI) applications and protocols over an ATM network.

The ID 2.0 (fat) driver is available for the following platforms:

- Windows NT[®] version 4.0

- Solaris™ versions 2.5.1, 2.6, 2.7, 2.8
- HP-UX 10.20
- NetWare® versions 4.10, 4.11, 5.0, 5.1
- Linux® (thin)



NOTE

For Windows® 2000 platforms, Interphase provides an NDIS ATM driver.

Each Integrated Driver release provides a standard set of features across all operating systems for which it is available. For each adapter, the driver supports the following:

- SONET (Synchronous Optical Network) framing standards for North America, and SDH (Synchronous Digital Hierarchy) framing standards for Europe
- Redundant link support, allowing configuration of primary and backup adapters in the same end station
- Up to 16 LAN Emulation Clients (LECs), and up to 16 LAN Emulation Servers (LEs) along with Broadcast and Unknown Servers (BUSs)
The NetWare driver supports up to 8 LEs.
- One LAN Emulation Configuration Server (LECS)
- One Classical IP-over-ATM (CIP) client and one CIP server, based on RFC 1577 and RFC 2225
- Switched Virtual Circuit (SVC) connections, based on the User-Network Interface (UNI) 3.0/3.1 and 4.0 signaling specifications
SVCs enable links between nodes to be set up and torn down dynamically for each data transmission.
- Permanent Virtual Circuit (PVC) connections between each client and other end stations, based on RFC 1483
- Simultaneous use of SVCs and PVCs throughout the network
- Definition of LEC-enhanced Virtual Circuits (VCs) so that VC connections for a LEC will be sustained if LANE services are lost
- Up to 4K Virtual Circuits (VCs)
- Configuration of a VPI other than 0 to be used by all services on an adapter
- ILMI Service Registry for primary LECS, which allows LECs to query the switch's Service Registry MIB for a list of LECS addresses and provides Cisco SSRP support.
- ILMI 4.0 autoconfiguration, which enables signaling to query the switch MIB and negotiate parameter setup, such as the UNI version.
- ABR support
- SNMP support

The installation package also includes the CellView™ utility, which you can use to configure adapters to the network and to view network operation statistics. Use CellView to configure redundancy, framing, ILMI options, client and server network support, and other features. The version of CellView described in [Using CellView for GUI Systems on page 53](#) is a cross-platform utility for systems with a Graphical User Interface (GUI). The version of CellView described in [Using CellView for NetWare Servers on page 121](#) is designed for NetWare systems, and has a textual user interface.

Minimum System Requirements

The following topics identify minimum system requirements for installing the adapter and the integrated driver on Windows NT, Solaris, NetWare, and HP-UX systems.

Windows NT

- Intel x86 or PowerPC running Microsoft Windows NT version 4.0
- CD-ROM drive
- 5 MB of free space on the hard disk
- System memory: 1 M per adapter and 800 K per client (for example, for 2 adapters each with 16 clients, you would need at least 2 M + (32 x 800 K))
- TCP/IP interface (if applicable)
 - IP addresses for each LEC and the CIP client
 - Subnet mask for each client

Solaris

- Intel® x86 or Pentium® system with PCI bus
- Solaris 2.x or Solaris 8 operating system
- CD-ROM drive
- A hard disk with free space consisting of:
 - 5MB in the /root partition
 - 1MB in the /usr partition
- System memory:
 - 16 MB minimum
 - Up to 24 MB with multiple clients and servers enabled
- Superuser login
- IP address, broadcast address, net mask, and ifconfig options for each client being initialized

HP-UX

- HP-UX PA-RISC CPU-based system with a VME or PCI bus

- HP-UX operating system version 10.20
- For hardware platforms S700 and S800 the following general release HP-UX 10.20 patch, available from Hewlett Packard:
 - Patch Name: PHSS_19592
 - Patch Description: s700_800 10.20 X/Motif Runtime SEP99 Cumulative Patch
 - Creation Date: 99/08/23
- CD-ROM drive
- A hard disk with free space consisting of:
 - 5 MB in the `/root` partition
 - 1 MB in the `/usr` partition
- System memory:
 - 16 MB minimum
 - up to 24 MB with multiple clients and servers enabled
- Superuser login
- IP address, broadcast address, net mask, and ifconfig options for each client being initialized

NetWare

- Intel x86 CPU file server running Novell NetWare version 4.10, 4.11, or 5.x
- CD-ROM drive
- 2 MB of free space on the hard disk
- System memory
 - 20 MB minimum
 - Up to 32 MB with multiple clients and LAN services enabled
- TCP/IP interface (if applicable)
 - IP address for each enabled client
 - IP mask

Overview

You can install your 6575 adapter in any 3U or 6U CompactPCI expansion slot.



NOTE

The 6575 faceplate is a 3U (specific length and width of the expansion slot opening) configuration. The CompactPCI cabinets also have a 6U mounting configuration. An extension bracket is available from third-party vendors to fit the 3U plate to a 6U slot. For information about where to buy this part, select the 6575 FAQ from the following Web address: <http://www.iphase.com/products/ProductFAQ.cfm>

The basic steps for installing the adapter are:

1. Verify that the system meets minimum requirements.
2. Review safety precautions.
3. Inspect the adapter.
4. Install the adapter in a host expansion slot.
5. Connect the adapter to the network.

Verifying Minimum Requirements

Before installing this adapter, verify that your system meets the minimum requirements described in [Minimum System Requirements on page 3](#).

Understanding Safety Precautions

The following general safety precautions must be observed during all phases of operation of this equipment. Failure to comply with these precautions or with specific warnings elsewhere in this manual violates safety standards of design, manufacture, and intended use of the equipment. Interphase Corporation assumes no liability for the user's failure to comply with these requirements. You, as the user of the product, must observe all stated warnings and safety precautions in order to safely operate the equipment in your environment.

Do Not Substitute Parts or Modify Equipment

Because of the danger of introducing additional hazards, do not install substitute parts or perform any unauthorized modification of the equipment. Contact your local Interphase representative for service and repair to ensure that safety features are maintained.

Ground the Instrument

To minimize shock hazard, the equipment chassis and enclosure must be connected to an electrical ground. The power cable must either be plugged into an approved three-contact electrical outlet or used with a three-contact to two-contact adapter, with the grounding wire (green) firmly connected to an electrical ground (safety ground) at the power outlet.

Do Not Operate in an Explosive Atmosphere

Do not operate the equipment in the presence of flammable gases or fumes. Operation of any electrical equipment in such an environment constitutes a definite safety hazard.

Keep away from Live Circuits

Do not install or replace the component with power cable connected. Under certain conditions, dangerous voltages may exist even with the power cable removed. To avoid injuries, always disconnect power and discharge circuits before touching them.

Observe Dangerous Procedure Warnings

Warnings precede potentially dangerous procedures throughout this manual. Instructions contained in the warnings must be followed. You should also employ all other safety precautions which you deem necessary for the operation of the equipment in your operating environment.



WARNING

This equipment generates, uses, and can radiate electromagnetic energy. It may cause or be susceptible to electromagnetic interference (EMI) if not installed and used in a cabinet with adequate EMI protection.

Inspecting the Adapter

Before installing the adapter in your computer, visually inspect it for damage that might have occurred during shipment from the factory.



CAUTION

The adapter is packed in an antistatic bag to protect it during shipment. Keep the adapter in its protective antistatic bag until you're ready to install it in the host computer. To prevent damage to the adapter due to electrostatic discharge, wear a grounding strap and handle the adapter only by its edges. Do not touch its components or any metal parts other than the faceplate. If your adapter is a fiber adapter, do not remove the connector cap(s) until you're ready to install the adapter.

1. Open the shipping container and carefully remove its contents.
2. Inspect each item for damage. If you find any omissions or damage, contact your supplier and the carrier (for example, UPS or Federal Express) that delivered the package.

Installing the Adapter

You can install your adapter in any computer cabinet containing a CompactPCI expansion slot.



WARNING

Your computer operates at voltages that can be lethal. Follow all cautions and warnings in this installation procedure, both to protect yourself and prevent damage to your computer. Use only tools with nonconductive handles, or tools coated with, covered with, or constructed of nonconductive materials. Nonconductive materials are materials that do not conduct electric current, such as plastic, rubber, and fiberglass.

With a grounding strap connected to your wrist or ankle, do the following to install the adapter:

1. Turn off the computer's power switch.
2. Unplug the unit from its power source
3. Locate a suitable expansion slot, and remove the two screws that attach the expansion plate to the computer. Then remove the expansion plate.



NOTE

If you are installing the adapter in a CompactPCI cabinet with a 6U mounting configuration, the adapter requires an extension bracket. See the Note on page 5 for details.

4. Insert the adapter in the two guide-slots, one located at the top of the expansion opening and the other located at the bottom.

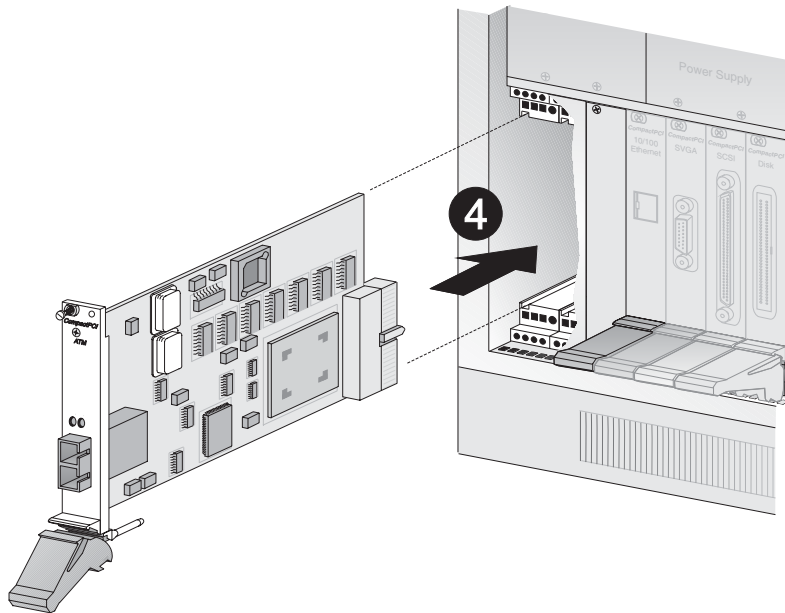

5. Push the board gently but firmly into the cabinet to seat it in the bus connector located at the back of the cabinet.

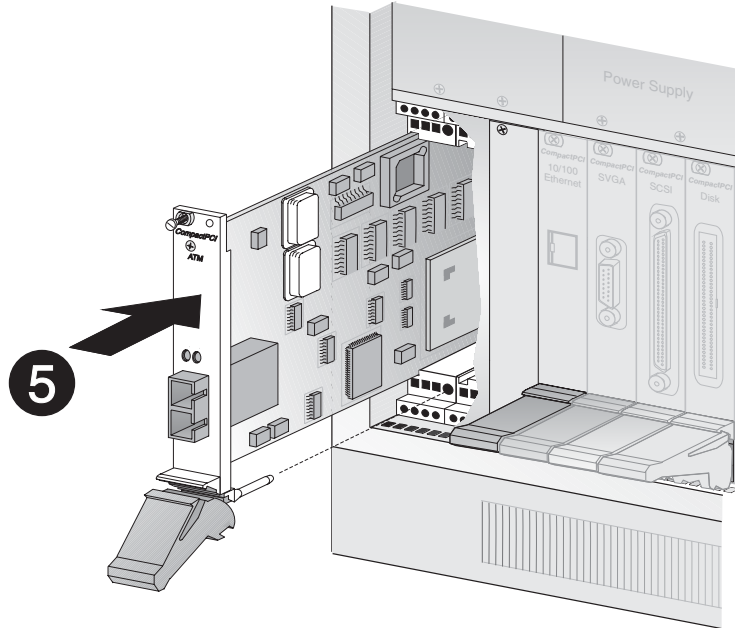

 **NOTE**

Due to the density of the pins in the CompactPCI bus, you might need to repeat the seating process several times until the connector snaps into place.

6. Engage the latch on the adapter to lock it to the chassis.

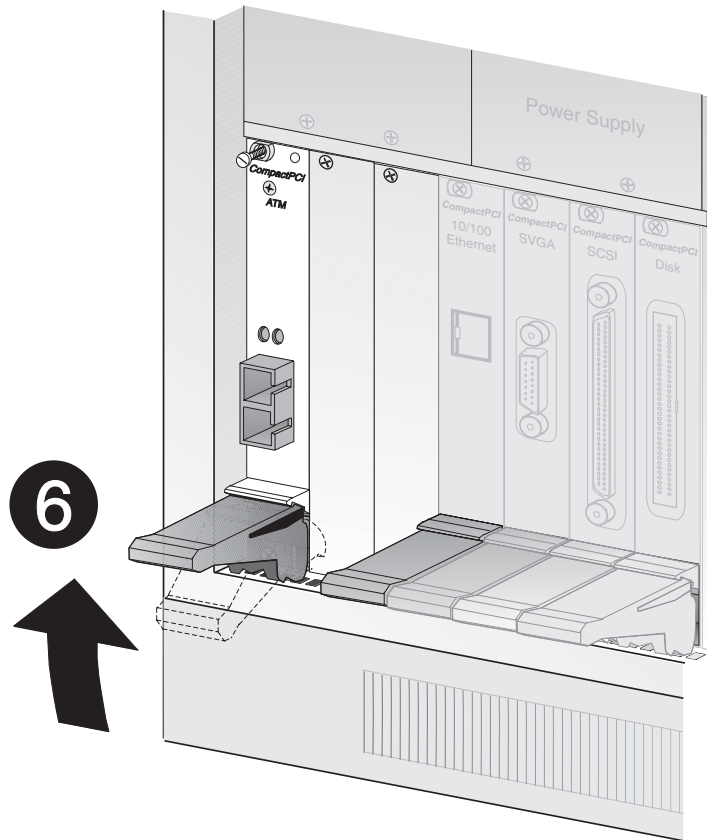

7. Secure the faceplate's upper screw to the chassis.

8. Secure the faceplate's lower screw to the chassis. This screw is encapsulated. It is located under the latch.

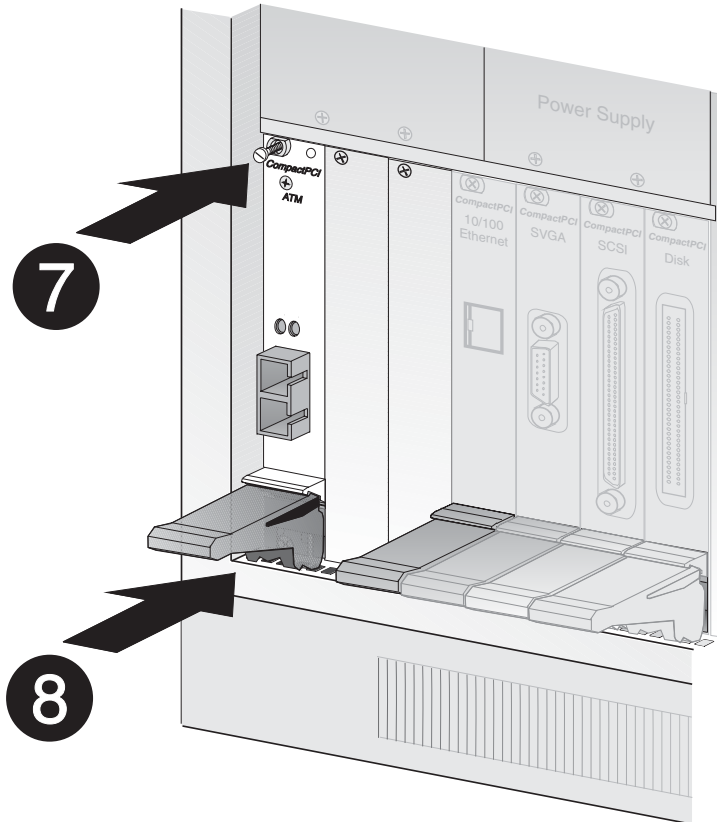

Connecting to the Network

With the adapter installed as discussed in the previous section, you are now ready to connect the adapter to the network. The following table identifies the cables and connectors required for the adapter:

Connector	Medium	Configuration
SC Duplex	Single-mode fiber	8.5/125 micron
	Multimode fiber	62.5/125 micron
RJ-45	Cat 5 copper	UTP

To connect the adapter to the network, do the following:

1. Attach the appropriate SC-duplex or RJ-45 network connector to your adapter, as shown in the following illustrations.

Following is the SC Duplex fiber connection:

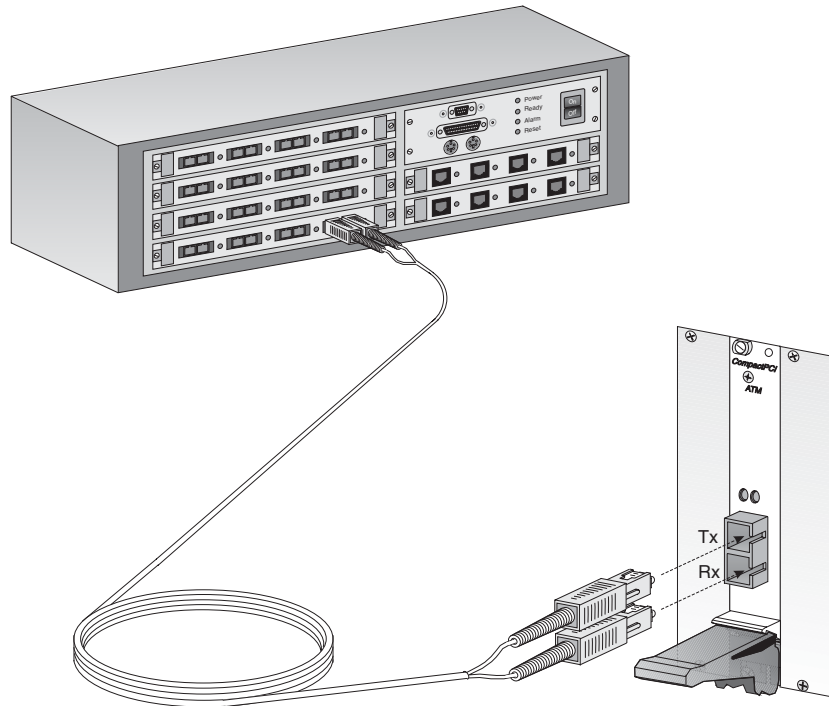

Following is the RJ-45 UTP connection:

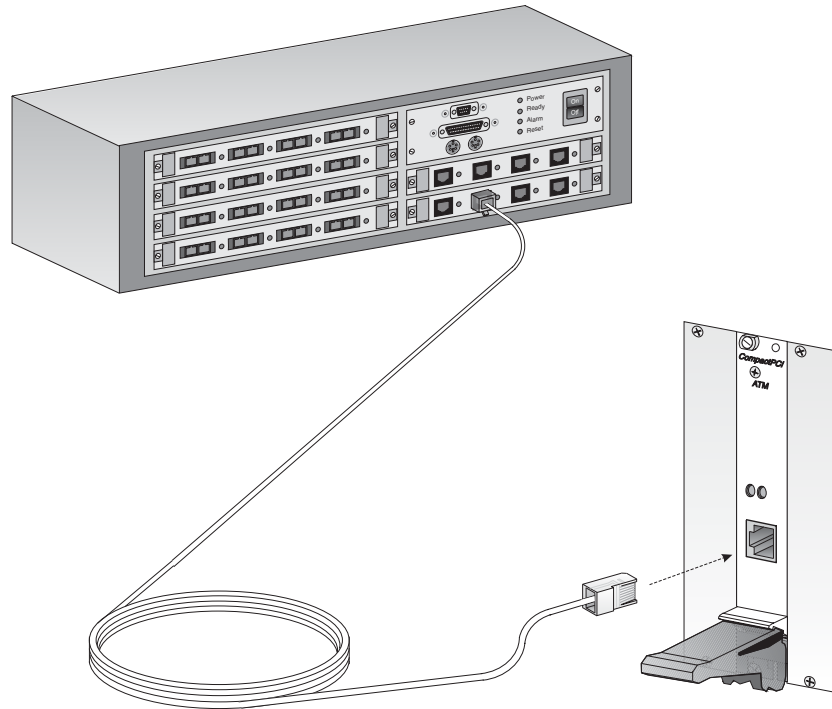

2. Reconnect the power cable and turn on the computer.

Installation of the adapter is complete. Next, install/create the adapter driver.

Go to the appropriate chapter based on your system requirements:

- [Installing the Windows 2000 Driver on page 15](#)
- [Installing the Windows NT Driver on page 21](#)
- [Installing the Solaris Driver on page 31](#)
- [Installing the HP-UX Driver on page 41](#)
- [Installing the NetWare Driver on page 107](#)

After the driver is installed go the appropriate chapter for instructions for loading and using the CellView utility:

- [Using CellView for GUI Systems on page 53](#)
- [Using CellView for NetWare Servers on page 121](#)

Overview

This chapter explains how to install your adapter's driver on a system running Windows 2000.

Make sure the Interphase ATM Adapter(s) are properly installed in the PCI slot before the computer is powered up. Also ensure that the target system(s) meet the minimum requirements for Windows 2000.

Microsoft has recommended that switch vendors supply switches with a default configuration that will allow a Windows client to immediately begin using LANE services after installation. The recommended default configuration is:

- LANE services should be enabled, including an LECS, LES, and BUS.
- In the LECS, discovery should be supported through the well-known address, well-known VCI and VPI, and ILMI.
- An ELAN should be associated with each LES. Base the ELAN name, LAN type, and maximum packet size on the legacy clients it will communicate with (for example, *Marketing, Ethernet, 1516*). The switch may require you to separately create a BUS for the LES. The Microsoft LEC supports either co-located or separate BUS addressing.



NOTE

There are two drivers available; A00 and A02.

The A00 driver is supplied with Windows 2000, and is installed following the procedures in [Installation \(A00 Driver\)](#).

The A02 driver, supplied by Interphase, provides added support for CBR and bug fixes for large VCI values, and is installed following the procedures in [Installation \(A02 Driver\)](#) on page 16.

You can find more information about Microsoft Windows ATM installation and configuration at:

For ATM services white paper:

<http://www.microsoft.com/windows2000/techinfo/howitworks/communications/trafficmgmt/atmsvcs.asp>

For Windows 2000 ATM Technical Reference:

<http://www.microsoft.com/technet/treeview/default.asp?url=/technet/prodtechnol/windows2000serv/reskit/intnetwk/part4/intch14.asp>

Installation (A00 Driver)

This Interphase PCI ATM driver is a certified Microsoft NDIS mini-port driver included on the Windows 2000 CD. This product is *Plug and Play*, (*PnP*) compatible. Starting the system after physically installing the first Interphase PCI ATM card will cause PnP to detect your card and load the updated NDIS 5.0 ATM miniport driver for your adapter to use, along with the Microsoft ATM UNI call manager (for signaling over ATM), Microsoft ATM LAN Emulation service, and other Windows ATM service components.

It is important to allow the Plug and Play Wizard to find the new hardware in order to avoid possible registry corruption.

After the driver is installed it may be necessary configure the ELAN membership for a client as follows:

1. On the desktop, click **My Computer**, then **Network Connections**, and select the ATM Connection corresponding to the installed ATM network adapter in the Device Name column. (If you do not see this column, you may need to select the Details view from the View menu.)
2. Right-click the connection, and select **Properties**.
3. In the list of network components used in this connection, select **ATM LAN Emulation Client**, and click **Properties**.
4. If needed, further configure the list of emulated LANs available for use with this ATM connection by adding the ELAN name. The *<unspecified ELAN name>* listing instructs the client to use the default ELAN.

Installation (A02 Driver)

Introduction

This driver, build 2271-24 or greater, is currently not Microsoft Certified and as such requires the following steps to install over the default Interphase driver provided by Microsoft, build 2128.

Create a Directory for the New Driver Files

1. `c:\temp\i386\ip5515.sys`
2. `c:\temp\i386\net5515n.inf`

Remove System Cache Entries for Default Driver

1. `cd \WINNT\driver cache\i386`
2. `Move driver.cab driver.cab.save`
3. `cd \WINNT\system32\dllcache` (this is a hidden folder).

In the `system32` folder:

- a. Select **Tools**
- b. Select **Folder options**
- c. Select the **View** tab
 - Select **Show Hidden files and folders**
 - Deselect **Hide protected operating system files**
 - Select **Yes** on the warning pop-up

4. Move `ip5515.sys` \temp\ip5515.b2128

Driver Upgrade

1. Right click on **My Computer**
2. Select **Manage**
3. Select **Device Manager**
4. Select **Network adapters**
5. Right click on Interphase 5525/5575 PCI ATM Adapter
6. Select `Properties`
7. Select the `Driver` tab
8. Select `Update Driver`, the system displays:
Welcome to the Upgrade Device Driver Wizard
9. Select `Next`, the system displays:
What do you want the Wizard to do?
10. Deselect `Search for a suitable driver for my device`
11. Select `Display a list of the known drivers for this device...`
12. Select `Next`
13. Select `Have Disk...`
14. Enter path `c:\temp` (it will automatically append \i386)
15. select Interphase 5525/5575 PCI ATM Adapter
16. Select `Next`, the system displays:
Digital Signature Not Found
This window explains that the new driver is not certified and asks if the user accepts the risk.
17. Select `Yes`, the path is displayed for verification

18. Select `OK`, the wizard closing window is displayed.
19. Select `Finish`

Initialize Advanced Driver Parameters

1. Right click `My Computer`
2. Select `Manage`
3. Select `Device Manager`
4. Select `Network adapters`
5. Right click `Interphase 5525/5575 PCI ATM Adapter`
6. Select `Properties`
7. Select the `Advanced` tab. [Table 3-1](#) provides a definition of the various parameters available.

Table 3-1. Driver Parameters

Parameter	Definition
Hash Table Size	Currently disabled, defines the drivers vpi/vci hash table size.
Receive Buffer Size	This parameter sets the driver MTU size. (Selections less than 18 K will cause the NDIS Classical IP interface not to function). Selection of 64 K (65536) will result in an MTU of 65464 because of the need to allow room for the CS5 trailer and the iChipSAR overrun errata. The driver will allocate buffers using the following algorithm: $MTU = (((MTU + sizeof(CS5))/CellSize) * CellSize) + CellSize$; and report the user selected MTU to NDIS.
Number of Map Registers	Engineering only, do not modify
SUNI Mode	This sets the line mode to SONET (0) or SDH (1).
SUNI Clk	This sets the transmit clock source to TXCI(0) or RXCI(1).
WAN Mode	4531 only, this parameter along with the following parameter, Framing Mode, sets the ATM framing for DS3/E3 interface to ADM (0) or PLCP (1).

Table 3-1. Driver Parameters (cont)

Parameter	Definition
Framing Mode	4531 only, this parameter along with the above parameter, WAN Mode, sets the ATM framing for DS3/E3 interface DS3 - CBIT (0) or M23 (1) E3 - G.832(0) or G.751(1)

VPI Information

There are four available VPI entries. Valid entries are 0 - 256, where 256 denotes that the VPI is not enabled.

They are scanned by the driver sequentially and scanning is halted when a VPI value of 256 is encountered.

Duplicate entries will be discarded.

- **Base VPI** - The primary VPI to use.
- **VPI 2** - second VPI to use.
- **VPI 3** - third VPI to use.
- **VPI 4** - fourth VPI to use.

VPI VC Information

There are entries available for each VPI to select the number of VCs to configure for that VPI.

Only the Base VPI is allowed to have a non-power of two value.

For VPI2 through VPI4 non-power of two values will be rounded up. (examples of valid entries are 32, 64, 128, 256, 512)

The user must insure that the number of VCs selected for the VPIs added up do not exceed the number supported by the hardware. This causes the driver to default to the base VPI with a VC count of the hardware limit.

- **Base VPI VC count** – VC count for the base VPI. The minimum value is 32 and the maximum is the hardware limit. (1024 or 4096). This value must be greater than any of the VPI2-VPI4 values.
- **VPI2 VC count** – VC count for second VPI. This value must be binary oriented. If not, the driver will round it up. This value must also be equal to or less than the Base VPI VC count.
- **VPI3 VC count** – VC count for third VPI. This value must be binary oriented. If not, the driver will round it up. This value must also be equal to or less than the Base VPI VC count.

- **VPI4 VC count** – VC count for fourth VPI. This value must be binary oriented. If not, the driver will round it up. This value must also be equal to or less than the Base VPI VC count.

Overview

This chapter explains how to install your adapter's driver on an end station running Windows NT version 4.0. It provides information about the following:

- Tasks that should be done before you start the installation, described in the next topic, *Before You Start*
- Considerations for setting up redundant link support, described in *Providing Redundant Link Support on page 22*
- Driver installation, described in *Installing the Driver on page 22*
- Driver removal, described in *Removing a Driver on page 28*

Before You Start

Before you install the driver, it is recommended that you:

- Read any *Read Me First* documentation in your installation kit.
- Make sure the computer meets the minimum requirements listed in *Minimum System Requirements on page 3*.
- Install the adapter card in the computer.
- Read through the entire sequence of installation steps.
- Back up the system.

Also do the following:

- Make sure your ATM switch supports the UNI 3.0, 3.1, or 4.0 signaling standard for SVCs.
Check your switch documentation for correct settings. By default, the adapter is automatically configured to the switch's UNI version.
- Decide whether to have the adapter obtain an IP address from a DHCP server or use a specified IP address. If it will use a specific IP address, gather the following:
 - Assigned IP Address for the adapter
 - Subnet Mask
 - Default Gateway IP address (optional)
- If a backup ATM adapter is being installed, review the guidelines in the next section, *Providing Redundant Link Support*.

Providing Redundant Link Support

Backup adapters (also called *secondary* or *redundant* adapters) provide end stations with redundant link support. A backup adapter takes on all the functions of an assigned primary adapter when the primary adapter experiences a physical line failure, or when a user deactivates the primary adapter. All the primary adapter's clients and IP addresses are moved onto the backup adapter until the primary adapter resumes operation or is manually reactivated.

At least two Interphase ATM adapters must be in an end station to configure redundant link support. There must be at least one primary adapter for each backup adapter.

A backup adapter can support one to seven primary adapters. For example, an end station can contain four primary adapters, each assigned to one of four backup adapters; or it can contain up to seven primary adapters, all assigned to one shared backup adapter. If the machine contains groups of adapters with different configurations, you might assign one backup adapter to each similarly configured group.

The board type of the backup adapter must be the same as the board type of its primary adapter(s). That is:

- A 155 Mbps adapter can back up only 155 Mbps adapters.
- A 155 Mbps with 4K VC adapter can back up only 155 Mbps with 4K VC adapters.

You are not able to designate backup and primary adapters during installation. However, if you know the backup adapter number during installation, we recommend that you add one client for that adapter and add a bogus IP address for that client. Only one client is used on backup adapters, for initialization purposes.

Available adapter numbers are determined by the number of adapters installed. Adapter 1 is always a primary adapter. We recommend that the highest available adapter number(s) be assigned to the backup adapter(s). For example, if your end station contains two primary and one backup adapters, identify adapters 1 and 2 as primary adapters, and adapter 3 as the backup adapter.

Installing the Driver

For Windows NT, the driver supports up to eight adapters per machine. It allows each adapter to join up to 16 different ELANs (Ethernet or Token Ring) and one Classical IP-over-ATM (CIP) segment simultaneously. During installation, you can initialize up to 16 LECs and one CIP client per adapter. Client 1 is enabled by default. All remaining clients and LAN services are disabled. (For detailed information about the driver features, see [Software Drivers on page 1](#).)

If an earlier version of a driver is installed on the end station, you must remove it before proceeding with the new driver. See [Removing a Driver on page 28](#) for instructions.

Starting the Installation



NOTE

Before you start, make sure the adapter is installed in your machine, and that you are logged on with administrator rights to the Windows NT 4.0 system.

To get started:

- Contact Interphase at swlib@iphase.com to determine if the driver on the CD (D04) is the latest, if not request the latest driver, installation instructions will be provided with this driver.
- If you are installing from an Interphase CD-ROM, insert the CD-ROM and run the self-extracting EXE file in the following directory, saving files to a subdirectory on your local hard drive:

```
<cdrom>:/drivers/6575/winnt/SX00168-D04.EXE
```

Then do the following:

1. From the **Start** menu, select **Settings**, and then **Control Panel**. Then double-click the **Network** icon, and select the **Adapters** tab to display the Network Adapters dialog box:

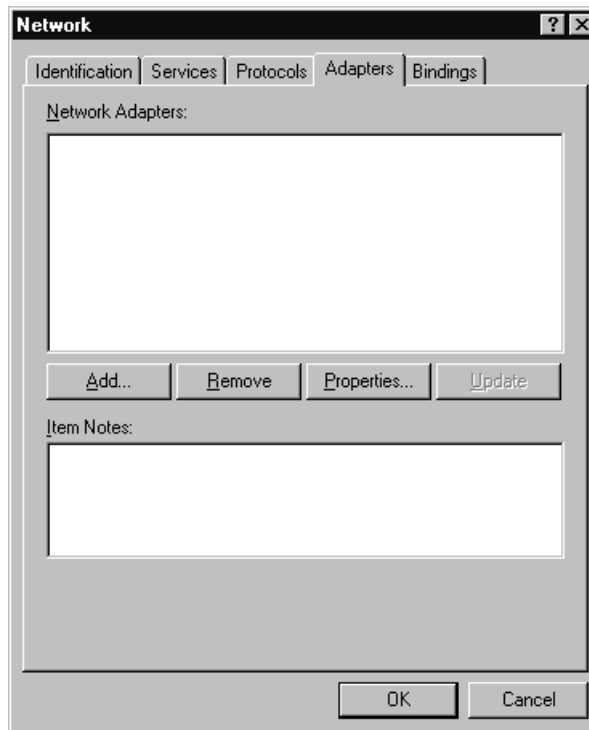

Figure 4-1. Adapters Dialog Box before Installation

2. To load the driver, click **Add**.

The system creates a driver list in the Select Network Adapter dialog box.

3. Click **Have Disk**.
4. When the Insert Disk dialog box appears, enter the directory created in the “To get started section”.
5. Click **OK**.
6. When the Select OEM Option dialog box appears, click **OK** to confirm the Interphase PCI ATM Adapter driver.

If you are adding additional adapters or clients and repeating the installation steps, a message informs you that a network card of this type is already installed. Click **OK** to continue.

The Interphase ATM Adapter Setup dialog box appears:

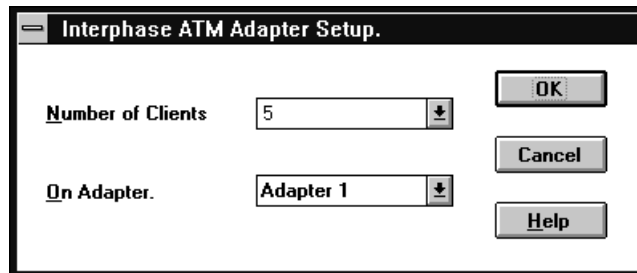

Figure 4-2. Interphase ATM Setup Dialog Box

7. In the **Number of Clients** field, select the number of LECs to install, or select **1577 ATM Client** to install a CIP client.

You can select up to 16 LECs (by selecting **1–16**) or one CIP client (by selecting **1577 ATM Client**).

If you want to install both LECs and a CIP client, first install the client(s) of one type. You can install the other client(s) by repeating installation steps.

If you are loading the driver for a backup adapter, install only one client, to use for initialization.

8. In the **On Adapter** field, select the adapter on which to install the clients and Click **OK**.
9. If SNMP support has not been installed, the following prompt asks if you want to install SNMP support for the ATM cards:



Figure 4-3. SNMP Support Installation

In most cases SNMP support should not be installed. This depends on the system's network configuration. The Windows SNMP service should be installed on the system before installing Interphase SNMP support.

- To install the driver software without SNMP support, click **No**, go to Step **14**.
- To install SNMP driver support for all the Interphase ATM cards on the system, click **Yes**, go to Step **10**.

- 10.** Go to the directory where you unzipped the Interphase `sx00168-D01` files.
- 11.** Look for the `snmpagent` directory and CD into it. Inside the `snmpagent` directory, run the `iph_snmpinstall.exe` file.
- 12.** When asked to Enter the Path from where the subagents should be install: type in the full path to the `snmpagent` directory.
Note: The directory you are currently in is the `snmpagent` directory.
- 13.** Run `snmp_config` to enable or to disable any of these agents.
- 14.** When the installation is complete, the Adapters dialog box reappears:

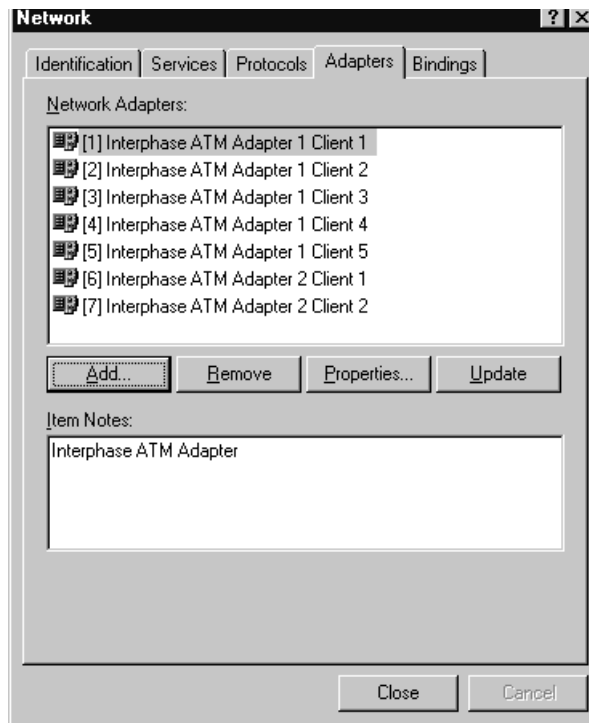

Figure 4-4. Adapters Dialog Box after Installation

The Installed Adapter Cards list includes the added adapter and client numbers. CellView will recognize clients by the client number.

- 15.** If needed, repeat steps **2** through **9** until all installed PCI ATM adapters are added to the system, and all LECs and/or CIP clients are installed for each adapter.

16. After you have added all adapters and clients, click **Close** in the Adapters dialog box.

If TCP/IP is installed on your computer, continue the installation with the procedures in the next section, *Configuring Network Protocols*. If TCP/IP is not installed, skip to *Completing the Driver Installation* on page 27.

Configuring Network Protocols

When you close the Adapters dialog box after adding clients, if TCP/IP is installed on your computer, the IP Address dialog box appears:

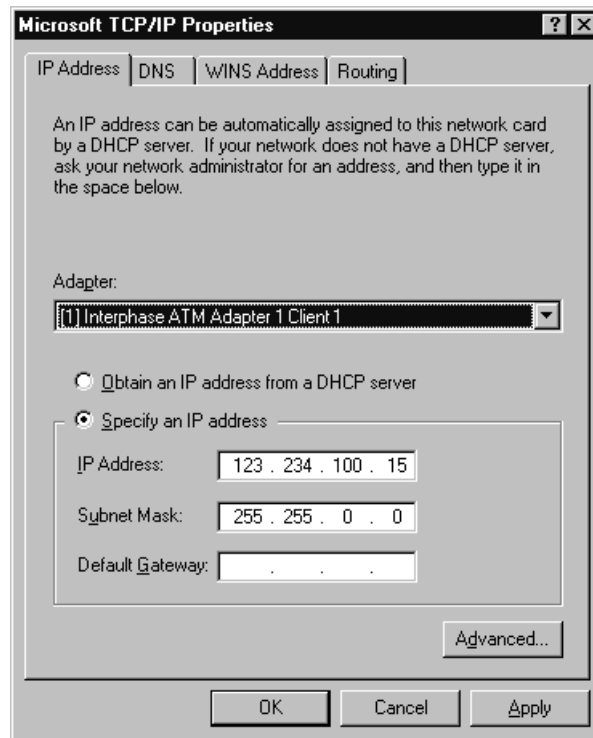

Figure 4-5. TCP/IP Settings

You must enter an IP address and subnet mask for all clients before exiting this dialog box. You can enter dummy numbers for clients that will not be enabled (such as on backup adapters).



NOTE

The IP addresses shown in **Figure 4-5** are examples only. Use the IP addresses for your network when editing the TCP/IP parameters.

To edit the TCP/IP properties:

1. Select a client to configure in the Adapter list box.
You can configure the clients in any order; however, it is recommended you work with Client 1 first.
2. Select one of the IP address options (**Obtain an IP address from a DHCP server** or **Specify an IP address**).
3. If you select to specify an IP address:
 - a. Supply an assigned **IP Address** and a **Subnet Mask**.
The IP address format is *xxx.xxx.xxx.xxx*, where *xxx* ranges from 0 to 254. The subnet mask is used to partition the IP address into subnets at the local company level.
 - b. If your local network has a gateway to other networks, supply your network's **Default Gateway** address to enable the host machine to communicate with machines on the other side.
4. If you select to obtain an IP address from a DHCP server, a message informs you that specified parameters will override values obtained by the DHCP, and asks if you want to enable DHCP.
Click **Yes** to enable DHCP, or **No** to not enable DHCP.
5. Enter additional information in the IP Address dialog box as required for your network. See your Microsoft NT documentation for details.
6. Repeat steps 1–5 until all clients are configured.
7. When the initial driver configuration is complete, click **OK** on the TCP/IP Properties window.

Continue to the next topic, [Completing the Driver Installation](#).

Completing the Driver Installation

When you finish the initial driver setup for all clients, complete the driver installation as follows:

1. After you click **Close** in the Adapters dialog box or click **OK** on the IP Address dialog box, the Network Settings Change pop-up appears, explaining that you must shut down and restart your computer for the new settings to take effect.
2. Click **Yes** to restart your computer.

Next, with the driver and adapter(s) installed, start CellView and configure the adapter(s) as described in [Using CellView for GUI Systems on page 53](#).

If you need to verify that the driver is up and running, see [Statistics Information on page 83](#).

Adding Clients after Driver Installation

If you need to add LEC or CIP clients after the initial driver installation, re-install the driver from the Interphase CD-ROM or temporary installation directory as instructed in [Installing the Driver on page 22](#).

When you are informed that a network card of this type is already installed, click **OK**. When you are prompted to enter the number of clients, select the number of LECs you are adding or select **ATM 1577 client** to add a CIP client.

Removing a Driver

To remove an adapter's driver from Windows NT:

1. Be sure you are logged on with administrator rights to the Windows NT system.
2. From the **Start** menu, select **Settings**, and then **Control Panel**. Then double-click the **Network** icon, and click the **Adapters** tab to display the Adapters dialog box.

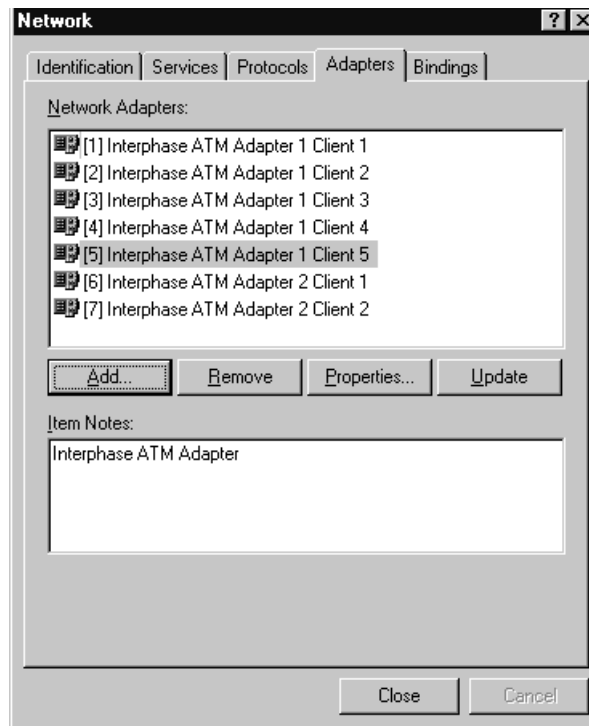

Figure 4-6. Adapters Dialog Box

3. Highlight the highest numbered client for the adapter whose driver you are removing, and click **Remove**.

The NT operating system does not allow you to remove drivers individually. You must remove them one client at a time. You can remove only the highest numbered

remaining LEC, one at a time. This restriction prevents possible client numbering conflicts.

4. When a warning message informs you that this action will permanently remove the component from the system and asks if you wish to continue, click **Yes**.
5. Repeat steps 3 and 4 until you have removed all clients on the adapter.
6. Click **Close** in the Adapters dialog box.
The Network Settings Change dialog box appears, explaining that you must shut down and restart your computer for the new settings to take effect.
7. Click **Yes** to restart the computer.

Overview

This chapter explains how to install your adapter's driver in an end station running Solaris version 2.5 or later. It provides information about the following:

- Tasks that should be done before you start the installation, described in the next topic, *Before You Start*
- Considerations for setting up redundant link support, described in *Providing Redundant Link Support on page 31*
- Driver installation, described in *Installing the Driver on page 32*
- Driver removal, described in *Removing the Driver on page 37*

Before You Start

Before you install the driver, it is recommended that you:

- Read any *Read Me First* documentation in your installation kit.
- Make sure the computer meets the minimum requirements listed in *Minimum System Requirements on page 3*.
- Install the adapter card in the computer.
- Read through the entire sequence of installation steps.
- Back up the system.

Also do the following:

- Make sure your ATM switch supports the UNI 3.0, 3.1, or 4.0 signaling standard for SVCs.

Check your switch documentation for correct settings. By default, the adapter is automatically configured to the switch's UNI version.

- If a backup ATM adapter is being installed, review the guidelines in *Providing Redundant Link Support*.

Providing Redundant Link Support

Backup adapters (also called *secondary* or *redundant* adapters) provide end stations with redundant link support. A backup adapter takes on all the functions of an assigned primary adapter when the primary adapter experiences a physical line failure, or when a user deactivates the primary adapter. All the primary adapter's clients and IP addresses are moved onto the backup adapter until the primary adapter resumes operation or is manually reactivated.

At least two Interphase ATM adapters must be in an end station to configure redundant link support. There must be at least one primary adapter for each backup adapter.

A backup adapter can support one to seven primary adapters. For example, an end station can contain four primary adapters, each assigned to one of four backup adapters; or it can contain up to seven primary adapters, all assigned to one shared backup adapter. If the machine contains groups of adapters with different configurations, you might assign one backup adapter to each similarly configured group.

The board type of the backup adapter must be the same as the board type of its primary adapter(s). That is:

- A 155 Mbps adapter can back up only 155 Mbps adapters.
- A 155 Mbps with 4K VC adapter can back up only 155 Mbps with 4K VC adapters.

Available adapter numbers are determined by the number of adapters installed. Adapter 0 is always a primary adapter. We recommend that the highest available adapter number(s) be assigned to the backup adapter(s). For example, if your end station contains two primary and one backup adapters, identify adapters 0 and 1 as primary adapters, and adapter 2 as the backup adapter.

Installing the Driver

For Solaris, the driver supports a total of eight adapters per end station. It allows each adapter to join up to 16 different ELANs (Ethernet or Token Ring) and one Classical IP-over-ATM (CIP) segment simultaneously. During installation, you can initialize up to 16 LECs and one CIP client per adapter. Client 0 is enabled by default. All remaining clients and LAN services are disabled.

The Solaris driver provides support for SNMP network management, with support for the ATOM, SONET, LEC, and ifStackTable Management Information Bases (MIBs). It also provides SNMP trap generation, based on RFC 1215, for standard errors such as CRC errors, SAR timeouts, and oversized SDUs. (For details about the driver features, see [Software Drivers on page 1](#).)

To get started:

- Contact Interphase at swlib@iphase.com to determine if the driver on the CD (D03) is the latest, if not request the latest driver, installation instructions will be provided with this driver.
- If you are installing from an Interphase CD-ROM, insert and mount the CD-ROM.

Then do the following:

1. Log in as **root**.
2. Check the available disk space by entering **df -k**
3. If needed, check for an existing installation of the driver by entering **pkginfo**. If **INPHatm**, **INPHia**, **INPHipatm**, or **INPHpa** is in the list of installed packages, remove it as explained in [Removing the Driver on page 37](#).
4. Run the installation script by entering the **pkgadd** command (where *<path>* is the location of the installation file).

```
pkgadd -d /<CDpath>/drivers/6575/solaris/ID2.0/sx00325.d03 INPHatm
```

The installation might take several minutes to complete.

The following is a sample of the screen output during driver installation. This sample shows two primary adapters and one backup adapter being configured. The prompts that appear on your screen during driver installation depend on your responses to prompts about adapters, SNMP options, and clients.

```
Processing package instance <INPHatm> from
/cdrom/drivers/.....
PCI ATM Integrated Driver
SX00325-D03

Enter maximum number of Adapters to configure (1-8) [1]: 3
Enter number of primary Adapters to configure (2-3) [3]: 2
Which adapter will backup primary Adapter 0? (0 for no backup) [2]:
Do you want to automatically switch back to primary when link returns? (y/n) [y]:
Which adapter will backup primary Adapter 1? (0 for no backup) [2]:
Do you want to automatically switch back to primary when link returns? (y/n) [y]:

Do you want SNMP management enabled (y/n) [y]:
SNMP management enabled
Should management of all MIBs be enabled (y/n) [y]: n
Should management of ATom MIB be enabled (y/n) [y]:
Should management of SOnet MIB be enabled (y/n) [y]:
Should management of LEC MIB be enabled (y/n) [y]:
Should management of ifStackTable be enabled (y/n) [y]:
Should trap generation be enabled (y/n) [y]:

Enter number of LE Clients for Adapter 0 to configure (0-16) [1]: 5
Enter hostname for interface li0 [engr-atm0]:
Enter hostname for interface li1 [engr-atm1]:
Enter hostname for interface li2 [engr-atm2]:
Enter hostname for interface li3 [engr-atm3]:
Enter hostname for interface li3 [engr-atm4]:
Enter number of IP-ATM Clients for Adapter 0 to configure (0-1) [0]: 1
Enter hostname for interface li16 [engr-atm 16]:

Enter number of LE Clients for Adapter 1 to configure (0-16) [1]: 6
Enter hostname for interface li32 [engr-atm32]:
Enter hostname for interface li33 [engr-atm33]:
Enter hostname for interface li34 [engr-atm34]:
Enter hostname for interface li35 [engr-atm35]:
Enter hostname for interface li36 [engr-atm36]:
Enter hostname for interface li37 [engr-atm37]:
Enter number of IP-ATM Clients for Adapter 1 to configure (0-1) [0]: 1
Enter hostname for interface li48 [engr-atm 48]:
```

Figure 5-1. Sample INPHatm Installation, Initial Prompts

5. Answer the prompts about adapters as follows:

- a.** Enter maximum number of Adapters to configure (1-8) [1]:

This is the number of PCI ATM adapters in the end station. Press **Enter** to accept the default of 1 adapter, or enter the actual number of installed adapters (1-8).

The system assigns adapter numbers starting with 0. For example, if eight adapters are installed, the adapter numbers will be 0-7.

- b. Enter number of primary Adapters to configure (x) [x]:

This is the number of adapters to be configured as primary adapters. The default (x) is the number of adapters identified in step **a**.

When you assign fewer than the number of installed adapters as primary, the script designates remaining adapters as backup adapters. **You must assign at least half of the installed adapters as primary.**

If you are not configuring backup adapters with this installation, press **Enter** to accept the default. Then skip to step **6**.

If you will designate backup adapters, enter the number of primary adapters.

- c. Which adapter will backup primary Adapter 0? [x]:

This prompt appears if the designated number of primary adapters is less than the number of installed adapters.

By default, the system assigns the highest available number of the installed adapters to back up the primary adapter in question. For example, the backup defaults to Adapter 3 if four adapters are installed, or Adapter 7 if eight adapters are installed.

Press **Enter** to accept the default backup adapter assignment, or enter the number of the adapter you want to use as the backup instead.

You can change the backup adapter assignment after driver installation using the CellView utility.

- d. Do you want to automatically switch back to primary when link returns? (y/n) [y]:

If you want the driver to automatically reactivate the primary adapter and deactivate the backup adapter after a failure condition is resolved, respond **y**.

If you want to manually reactivate the primary adapter after a failure condition, respond **n**. (You can manually reactivate the adapter using CellView or the **r1s** command.)

6. Answer the prompts about SNMP management options as follows:

- a. Do you want SNMP management enabled (y/n) [y]:

The SNMP network management tool is supplied by Sun Microsystems, Inc. It must be installed on your system to be used with the Interphase driver.

If you do not want to enable SNMP management, respond **n**, and go to step **7**.

If you want to enable SNMP management, respond **y**. A message notifies you that SNMP is enabled.

- b. Should management of all MIBs be enabled (y/n) [y]:

Enter **y** to enable management of all of the following: AToM MIB, SONET MIB, LEC MIB, ifStackTable.

Enter **n** to enable these MIB options individually.

If you respond no, a series of prompts appears, each asking whether to enable one of these options. Respond **y** or **n** for each option, as needed for your system.

- c. Should trap generation be enabled (y/n) [y]:

The driver uses trap generation with SNMP management to track different types of standard errors, such as CRC errors, SAR timeouts, and oversized SDUs.

Respond **y** to enable trap generation, or **n** to disable trap generation.

7. Answer the prompts about LECs as follows:

- a. Enter LE Clients for Adapter <x> to configure (0-16) [1]:

This is the number of LECs you want to initialize for Adapter<x>. You can initialize a maximum of 16 LECs per adapter. You can also choose to not initialize any LECs on the adapter. Press **Enter** to accept the default of one LEC, or enter the actual quantity (0-16).

- b. Enter hostname for interface li<n>:

This is the hostname for the LEC IP interface li<n>, where <n> represents the IP interface number of the LEC. LECs are mapped to the IP interface with the formula:

$$IP\ interface=(adapter\ number * 32) + client\ number$$

For example:

```
li0 = adapter 0, LEC 0
li1 = adapter 0, LEC 1
li2 = adapter 0, LEC 2
...
li15 = adapter 0, LEC 15
li32 = adapter 1, LEC 0
li33 = adapter 1, LEC 1
...
li 47= adapter 1, LEC 15
...
li224= adapter 7, LEC 0
...
li239 = adapter 7, LEC 15
```

8. Answer the prompts about CIP clients (termed IP-ATM clients) as follows:

- a. Enter number of IP-ATM Clients for Adapter 0 to configure (0-1) [0]:

You can initialize only one CIP client per adapter. Press **Enter** to accept the default of 0, or enter **1** to initialize one CIP client.

- b. Enter hostname for interface li<n>:

This prompt appears **only if you initialized a CIP client**.

In this case, <n> is the IP interface number of the CIP client. CIP clients are mapped to the IP interface with the formula:

$$IP\ interface=(adapter\ number * 32) + 16$$

For example, for the CIP client on Adapter 0, <n> is 16; on Adapter 1, <n> is 48; and on Adapter 7, <n> is 240.

9. If you are installing multiple adapters, repeat steps 5c through 8 until all adapters are processed.

After you finish specifying clients for each adapter, various advisory and status messages appear, as shown in the following illustration:

```

Don't forget to add the following host names to the hosts database:

engr-atm0
engr-atm1
engr-atm2
engr-atm3
engr-atm4
engr-atm16

engr-atm32
engr-atm33
engr-atm34
engr-atm35
engr-atm36
engr-atm37
engr-atm48

Don't forget to update your netmasks database with the
correct information for the 13 interfaces.

## Processing package information.
## Processing system information.
## Verifying disk space requirements.
## Checking for conflicts with packages already installed.
## Checking for setuid/setgid programs.

This package contains scripts which will be executed with super-user permission
during the process of installing this package.

Do you want to continue with the installation of this package [y,n,?] y

```

Figure 5-2. Sample INPHatm Installation, Reminder Prompts

10. Note the host name and netmask information to add to the hosts database and netmasks database after the installation.
11. At the final prompt, Do you want to continue with the installation of this package, respond with **y** if you want to continue.
(Or respond **n** to cancel the installation and delete the temporary file holding the work done to this point.)
12. When installation of the driver is complete, remove the CD-ROM from the local drive and reboot the machine with the command:

```
shutdown -y -i6 -g0
```

Next, with the driver and adapter(s) installed, use the CellView utility to configure the adapter(s) for network operation. See *Using CellView for GUI Systems* on page 53.

**CAUTION**

All configuration data is stored in the file `/etc/atm/cvconf`, for which an online man page is available. Use the CellView utility to modify the parameters instead of editing them manually. If the parameters get out of sync, the driver may not work properly.

If for some reason CellView does not run on your system, you can use command-line utilities (such as `lec`, `les`, and `lecs`) to modify the software currently running. However, these commands do not change the permanent settings in the `cvconf` file. The effects of these commands are lost when the machine is turned off or restarted.

Do not mix the running of command-line and CellView utilities. Use one method consistently, or unpredictable results can occur.

Adding Clients after Driver Installation

If you need to add clients to the adapter after the initial driver installation, use CellView to do so.

Removing the Driver

To remove a driver from the end station, do the following:

1. Log in as root.
2. To remove the driver, enter the `pkgrm` command followed by the driver name. For example, to remove **INPHatm**, enter the command:

```
pkgrm INPHatm
```
3. Answer the prompts or press **Enter** to accept each default, as shown in [Figure 5-3 on page 38](#).
4. Reboot the machine by typing:

```
shutdown -y -g0 -i6
```

**CAUTION**

When the driver package is removed from a system, the configuration file `/etc/atm/cvconf` is saved as `/etc/atm/cvconf.save`. If an the driver package is installed again, `/etc/atm/cvconf.save` can be moved to `/etc/atm/cvconf` to quickly restore the configuration of the previous installation.

```

The following package is currently installed:
INPHatm      PCI ATM Integrated Driver
              (sparc) SX00325-D05

Do you want to remove this package [y,n,?,q] y
## Removing installed package instance <INPHatm>

This package contains scripts which will be executed
with super-user permission during the process of removing this package.

Do you want to continue with the removal of this package [y,n,?,q] y
## Verifying package dependencies.
## Processing package information.
## Executing preremove script.
Device busy
Cannot unload module: ia
Will be unloaded upon reboot.
Device busy
Cannot unload module: li
Will be unloaded upon reboot.
Usage: /usr/sbin/unlink name

## Removing pathnames in class <sed>
Modifying /etc/path_to_inst
Modifying /etc/devlink.tab
## Removing pathnames in class <none>
/usr/share/man/man7/li.7
/usr/share/man/man7/ia.7
/usr/share/man/man1m/sigstat.1m

:
:
/bin/cvconf
/bin/cellview
/Xlphase

## Updating system information.
Removal of <INPHatm> was successful.

```

Figure 5-3. Sample of Driver Removal

ATM AAL5 API Driver

This software allows transmission and reception of AAL5 frames from the application space.

Opening, closing and setting the parameters of each ATM connection is done through a well-defined API. A separate Stream and a unique UNIX file descriptor is associated with each connection. The AAL5 frames are transmitted and received by calling the standard UNIX system calls. The hardware driver in this package is not a DLPI driver and is not designed to work with the networking protocols in the system, such as TCP/IP.

The features and limitations of this driver are as follows:

- Supports multiple VPIs
- UBR service category is supported
- AAL5 adaptation layer is supported

- OC3, DS3 and E3 physical layers are supported
- Multiple adapters in a system are supported
- The driver supports multi-processor systems
- Both 4 K and 1 K VC adapters are supported
- Command for listing adapter and driver statistics

Installation

The 6575 Solaris AAL5 ATM driver is installed with the `pkgadd` utility. Change directory to the directory containing the driver. Enter

```
pkgadd -d ./SX00498-A06 INPHatm
```

and follow the instructions as they appear on the console.

Use `man aalapi` for details on using the API.

Overview

This chapter explains how to install your adapter's driver on an end station running HP-UX 10.20. It provides information about the following:

- Tasks that should be done before you start the installation, described in the next topic, [Before You Start](#)
- Considerations for setting up redundant link support, described in the next topic, [Providing Redundant Link Support](#)
- Driver installation and configuration, described in [Installing and Configuring the Driver on page 42](#)
- How to install additional clients on an adapter, described in [Adding Clients after Driver Installation on page 46](#)
- Driver removal, described in [Removing the Driver on page 47](#)

Before You Start

Before you install the driver, it is recommended that you:

- Read any *Read Me First* documentation in your installation kit.
- Make sure the computer meets the minimum requirements listed in [Minimum System Requirements on page 3](#).
- Install the adapter card in the computer.
- Read through the entire sequence of installation steps.
- Back up the system.

Also be sure to do the following:

- Make sure your ATM switch supports the UNI 3.0, 3.1, or 4.0 signaling standard for SVCs.

Check your switch documentation for correct settings. By default, the adapter is automatically configured to the switch's UNI version.

- Determine the assigned IP address and subnet mask address for the adapter.
- If a backup ATM adapter is being installed, review the guidelines in [Providing Redundant Link Support on page 42](#).

Providing Redundant Link Support

Backup adapters (also called *secondary* or *redundant* adapters) provide end stations with redundant link support. A backup adapter takes on all the functions of an assigned primary adapter when the primary adapter experiences a physical line failure, or when a user deactivates the primary adapter. All the primary adapter's clients and IP addresses are moved onto the backup adapter until the primary adapter resumes operation or is manually reactivated.

At least two Interphase ATM adapters must be in an end station to configure redundant link support. There must be at least one primary adapter for each backup adapter.

A backup adapter can support one to seven primary adapters. For example, an end station can contain four primary adapters, each assigned to one of four backup adapters; or it can contain up to seven primary adapters, all assigned to one shared backup adapter. If the machine contains groups of adapters with different configurations, you might assign one backup adapter to each similarly configured group.

The board type of the backup adapter must be the same as the board type of its primary adapter(s). That is:

- A 155 Mbps adapter can back up only 155 Mbps adapters.
- A 155 Mbps with 4K VC adapter can back up only 155 Mbps with 4K VC adapters.

If you know the backup adapter number during installation, we recommend that you install one client for that adapter and add a bogus IP address for that client. Only one client is used on backup adapters, for initialization purposes.

Available adapter numbers are determined by the number of adapters installed. Adapter 0 is always a primary adapter. We recommend that the highest available adapter number(s) be assigned to the backup adapter(s). For example, if your end station contains two primary and one backup adapters, identify adapters 0 and 1 as primary adapters, and adapter 2 as the backup adapter.

Installing and Configuring the Driver

For HP-UX, the driver supports a total of eight adapters per end station. It allows each adapter to join up to 16 different ELANs (Ethernet or Token Ring) and Classical one IP-over-ATM (CIP) segment simultaneously. During installation, you can initialize up to 16 LECs and one CIP client per adapter. Client 0 is enabled by default. All remaining clients and LAN services are disabled. (For detailed information about the driver features, see [Software Drivers on page 1.](#))

Starting the Installation

To get started:

- If you are installing from the compressed installation file `SX00353-D01` available at the Interphase web site:

- If needed, download the file as instructed in [Documentation Updates on page viii](#).
- Create a temporary installation directory (for example `/tmp/ATMDriver`).
- Extract the files in the downloaded file to the temporary installation directory.
- If you are installing from an Interphase CD-ROM, insert the CD-ROM in the appropriate drive and mount the CD-ROM. (For example, enter `mount /dev/dsk/c1t2d0 /cdrom`.)

Then do the following:

1. Log in as **root**.
2. If needed, check for an existing installation of the driver by entering `swlist`. If **INPHID1** is in the list of installed packages, remove it as explained in [Removing the Driver on page 47](#).
3. Create a temporary directory to hold the driver and utility files, and change to that directory.
4. Extract the `README` and `INPHID1.tar` files using the `tar` command, as follows:
 - If installing from a downloaded file, enter:

```
tar -xvf /<path>/SX00353-D01
```

 (where `<path>` is the path of the downloaded `sx353d00.tar` file)
 - If installing from CD-ROM, enter:

```
tar -xvf /cdrom/SX00353-D01
```
5. Verify that the required PCI kernel services exist.
 - a. Run **sam**.
 - b. Select **Kernel Configuration**.
 - c. Select **Drivers**.
6. Look at the `GSCtoPCI` driver and determine the current state. If the current state is `In`, go to Step 7, otherwise continue with the following steps.
 - a. Select the **GSCtoPCI** driver.
 - b. Select **Actions**.
 - c. Select **Add Driver to Kernel**.
 - d. Select **Actions**.
 - e. Select **Create a New Kernel**.
 - f. Select **Move kernel into place and reboot**.
7. Install the Interphase ATM driver software as `root` as follows:

```
swinstall -s /<cdrom>/drivers/6575/hpux/SX00353-D01
```

 A window is displayed providing information about the driver to be installed.

8. Mark the **INPHID1** package for install; then from the **Actions** menu, select **Install**.
9. Click **OK** and follow the on-screen prompts to complete the installation.



NOTE

This distributes the files packaged in the `INPHID1.tar` file. It does not change the contents of the temporary directory.

Continue as described in the next section, [Configuring the Driver to the Network](#).

Configuring the Driver to the Network

To configure the driver to automatically start at boot time, add the correct net addresses and `netmask` values for each LI client interface to the `INPHID1` startup data file. These values will be used by the `inphid1_startup` script to initialize clients when run manually or automatically during reboot operations.



CAUTION

Note that if other IP nodes are on the host system (for example, an Ethernet interface), the IP address used for each ATM interface must be in a totally separate network segment. For example, if the same segment as the Ethernet is used, routing and broadcast problems will occur because the network layer will assume that both devices are physically on the same segment.

To start, first determine the IP address of the ATM adapter. Then do the following:

1. Use `vi` to edit the `/etc/rc.config.d/liconf` file.
For each adapter, the `liconf` file contains 17 sets of lines to use to configure clients' interface names, IP addresses, and subnet mask addresses. The first 16 sets of lines (for `li0-li15`) represent 16 LECs, and the last set of lines (`li16`) represents one CIP client. By default, all sets of commands are commented out with a `#` except the first, which represents the first LEC on the adapter.
2. For each client to be installed on each adapter, remove the comment mark (`#`) from the command lines to enable the client, and enter the appropriate network address values. The following example shows two LECs and a CIP client specified.

Example:

```
INTERFACE_NAME[0]=li0
IP_ADDRESS[0]=129.100.100.55
SUBNET_MASK[0]=255.255.255.0
INTERFACE_NAME[1]=li1
```

```
IP_ADDRESS[1]=129.101.100.55
SUBNET_MASK[1]=255.255.255.0
```

```
.
.
```

```
INTERFACE_NAME[16]=li16
IP_ADDRESS[16]=129.132.100.55
SUBNET_MASK[16]=255.255.255.0
```

Use interface names `li0` through `li16` for LECs; use interface name `li16` for a CIP client.

3. To initialize and start the driver, execute the startup script as `root` as follows:

```
/sbin/init.d/inphid1 start
```

Use CellView to set up LECs. See [Using CellView for GUI Systems on page 53](#) for instructions.

Verifying the Installation

Verify the installation and operations as follows:

- To manually verify that the driver is installed and operational, use the following command:

```
netstat -i
```

This will show all inactive and active LI interfaces.

- Confirm the configuration with the following command:

```
/etc/ifconfig li0
```

This will show the driver as UP with the correct address, netmask, and MTU.

- Verify `signald` is running as follows:

```
ps -e | grep signald
```

- To confirm that a specific client is enabled, use the `ledbg` command. For example, to verify that client 0 on board 0 is enabled, enter:

```
ledbg -a0 -u0
```

Note that results may be misleading if `signald` is not running.

Configuring Clients Manually

As a general rule, use CellView to enable, disable, and configure clients on the adapter. See [Using CellView for GUI Systems on page 53](#) for instructions.



CAUTION

All configuration data is stored in the file `/etc/atm/cvconf`, for which an online man page is available. Use the CellView utility to modify the parameters instead of editing them manually. If the parameters get out of sync, the driver may not work properly.

If for some reason CellView does not run on your system, you can use command-line utilities (such as `lec`, `les`, and `lecs`) to modify the software currently running. However, these commands do not change the permanent settings in the `cvconf` file. The effects of these commands are lost when the machine is turned off or restarted.

Do not mix the running of command-line and CellView utilities. Use one method consistently, or unpredictable results can occur.

If it is necessary to enable a client manually, do the following:

1. Edit the file `/etc/atm/cvconf`.

In this file, select the Maximum Frame Size for the client. Do so by setting the `maxframesz` line to a number between 1 and 3, where 1 is a 1516 byte frame, 2 is a 4544 byte frame, and 3 is a 9234 byte frame. All clients on an Emulated LAN must have the same frame size.

See the `cvconf` man page for more information on the fields in this file.

2. Reboot the system. This will cause the LANE configuration script `/usr/bin/cvconf` to run, which will enable the clients specified by the `/etc/atm/cvconf` file.

If you do not want to reboot the system, run the following commands to reconfigure the LANE driver:

- a. Run the shutdown script as follows:

```
/sbin/init.d/inphid1 stop
```
- b. Run the startup script as follows:

```
/sbin/init.d/inphid1 start
```

Message Logging

Messages from the driver and `signalD` are logged to a file named `/usr/adm/signalD.log`. If you encounter problems setting up clients, review this file.

Adding Clients after Driver Installation

The driver allows 16 LECs and one CIP client per adapter. If you need to add network clients for one or more Interphase ATM adapters after the initial driver installation, do so as instructed in [Configuring the Driver to the Network on page 44](#).

Removing the Driver

To delete the configuration and uninstall the interface do the following:

1. Log in as root.
2. To stop signaling, execute the following script:
`/sbin/init.d/inphid1 stop`
3. Run **sam**
 - a. Select **Kernel Configuration**
 - b. Select **Drivers**
 - c. Select the **li** driver
 - d. Select **Actions**
 - e. Select **Remove Driver from Kernel**
 - f. Select **Actions**
 - g. Select **Create a New Kernel**
 - h. Select **Move Kernel into place and continue shutdown**



NOTE

Do not become alarmed when, at boot time, there is an error starting the Interphase software.

4. To remove the driver, enter the **swremove** command as follows:

```
swremove INPHID1
```

This will remove the software package from the system, but does not delete the contents of the temporary installation directory. Re-installation is possible as described above.

SNMP Sub-Agent

Installation

1. Install the Interphase ATM adapter and driver software.
2. Create a temporary directory to hold the SNMP software distribution.
3. Untar the driver tar file to your temporary directory:

```
tar xvf /<cdrom>/drivers/6575/hpux/snmp/sx00388.a00 /<temporary dir>/
```

4. Install the Interphase SNMP software as root as follows:

```
swinstall -s /<temporary dir>/INPHSNMP.tar
```

5. The SNMP subagent will automatically start each time the host system is restarted. The SNMP subagent may also be started executing the startup script as root, as follows:

```
/sbin/init.d/inphsnmp start
```

Overview

The features and limitations of this driver are as follows:

- A single VPI (VPI value of 0) is supported.
- Supports 4 K VCs for the server board (with 512 K control memory) and 1 K VCs for the client board (with 128 K control memory).
- Service categories UBR, ABR and CBR are supported.
- Only AAL5 is supported.
- Supports setting of PCR on the VCs.
- Multiple adapters in a system are supported.
- All variants of Interphase ATM PCI (i)Chip adapter cards are supported, including x575 (OC3, control memory 128 K, 512 K, and packet memory 128 K, 512 K, and 1 M), x525 (UTP25), and x531 (DS3 and E3).
- Only x86 platforms are supported.
- SMP is supported.

This release contains the following files:

- `iphase.h` – This header file contains the defines for the main IA driver source file, `iphase.c`.
- `iphase.c` – This is the IA driver main source file.
- `suni.c` – Interphase PHY chip driver (replace existing `suni.c`)
- `suni.h` – Interphase PHY chip header (replace exiting `suni.h`)

Installing the Adapters in the System

To install the ATM adapters in the system, do the steps below.

1. Login as root.
2. Shut down the system and power off the system.
3. Install one or more ATM adapters in the system.
4. Connect each adapter to a port on an ATM switch. The green 'Link' LED on the front panel of the adapter will be on if the adapter is connected to the switch properly when the system is powered up.
5. Power on and boot the system.

Copy the Driver Source Code to the Kernel Source Directory

If you don't have the kernel and ATM source, go to:

<http://icawww1.epfl.ch/linux-atm>

<http://www.kernel.org>

to get the source and learn how to build the kernel. If you already have the sources, copy `iphase.c` and `iphase.h` to the `linux/drivers/atm` directory.

Note that the drivers are compatible with kernel version 2.2.x and 2.3.x and ATM tool version 0.57 and later. For older version of kernel and ATM source, it may work but it was not tested.

Rebuild Kernel with ATM Driver Support

1. Reconfigure the kernel, choose the Interphase ia driver using `make menuconfig` or `make xconfig`.
2. Rebuild the kernel, loadable modules and the ATM tools.
3. Install the new built kernel and modules and reboot.

Load the Adapter Hardware Driver (ia Driver) if it is Built as a Module

1. Run `"insmod suni.o;insmod iphase.o"`

The yellow 'status' LED on the front panel of the adapter will blink while the driver is loaded in the system.

2. To verify that the 'ia' driver is loaded successfully, run the following command:

```
cat /proc/atm/devices
```

If the driver is loaded successfully, the output of the command will be similar to the following:

```
Itf Type      ESI/"MAC"addr AAL(TX,err,RX,err,drop) ...  
0  ia        xxxxxxxxxx 0 ( 0 0 0 0 0 ) 5 ( 0 0 0 0 0 )
```

You can also check the system log file `/var/log/messages` for messages related to the ATM driver.

ia Driver Configuration

Configuration of Adapter Buffers

The (i)Chip boards have three different packet RAM size variants: 128 K, 512 K, and 1 M. The RAM size decides the number of buffers and buffer size. The default size and number of buffers are set as listed in table1.

Table 7-1. Buffers

Total RAM Size	Rx RAM Size	Tx RAM Size	Rx Buf Size	Tx Buf Size	Rx Buf Cnt	Tx Buf Cnt
128 K	64 K	64 K	10 K	10 K	6	6
512 K	256 K	256 K	10 K	10 K	25	25
1 M	512 K	512 K	10 K	10 K	51	51

These setting should work well in most environments, but can be changed by entering the following command:

```
insmod<IA_DIR>/ia.oIA_RX_BUF=<RX_CNT>IA_RX_BUF_SZ=<RX_SIZE> \
IA_TX_BUF=<TX_CNT> IA_TX_BUF_SZ=<TX_SIZE>
```

Where:

- RX_CNT = Number of receive buffers in the range (1-128)
- RX_SIZE = Size of receive buffers in the range (48-64K)
- TX_CNT = Number of transmit buffers in the range (1-128)
- TX_SIZE = Size of transmit buffers in the range (48-64K)



NOTES

Transmit and receive buffer size must be a multiple of 4.

Care should be taken so that the memory required for the transmit and receive buffers is less than or equal to the total adapter packet memory.

Turn on ia Debug Trace

When the ia driver is built with the `CONFIG_ATM_IA_DEBUG` flag, the driver can provide more debug trace if needed. There is a bit mask variable, `IADebugFlag`, which controls the output of the traces. You can find the bit map of the `IADebugFlag` in `iphase.h`.

The debug trace can be turn on through the `insmod` command line option, for example, "`insmod iphase.o IADebugFlag=0xffffffff`" can turn on all the debug traces together with loading the driver.

ATM Stack Configuration

For LAN Emulation and Classical IP/IP-over-ATM support, go to the following Linux site:

<http://www.linux.org/docs/ldp/howto/ATM-Linux-HOWTO/index.html>

1a Driver Test Using `ttcp_atm` and PVC

For the PVC setup, the test machines can either be connected back-to-back or through a switch. If connected through the switch, the switch must be configured for the PVC(s).

UBR Test

1. At the test machine intended to receive data, enter:

```
ttcp_atm -r -a -s 0.100
```

2. At the other test machine, enter:

```
ttcp_atm -t -a -s 0.100 -n 10000
```

3. Run "`ttcp_atm -h`" to display more options of the `ttcp_atm` tool.

ABR Test

It is the same as the UBR testing, but with an extra command option:

```
-Pabr:max_pcr=<xxx>
```

where:

xxx = the maximum peak cell rate, from 170 - 353207.

This option must be set on both machines.

CBR Test

It is the same as the UBR testing, but with an extra command option:

```
-Pcbr:max_pcr=<xxx>
```

where:

xxx = the maximum peak cell rate, from 170 - 353207.

This option may only be set on the transmit machine.

Overview

This chapter provides information about how to use the GUI CellView connectivity management utility to set up and monitor network clients and servers on Interphase ATM adapters. This chapter describes the cross-platform version of CellView for Windows, Solaris, and HP-UX systems. The text-based version for NetWare systems is described in [Using CellView for NetWare Servers on page 121](#).

This chapter provides information about the following:

- CellView features, described in [CellView Features on page 53](#)
- Information to consider before you use CellView, described in [Before You Start on page 54](#)
- CellView startup procedure, described in [Starting CellView on page 56](#)
- Main CellView options, described in [CellView Adapter Interfaces and Actions on page 57](#)
- Setup procedures, described in [Setting Up ATM Network Services on page 59](#)
- CellView statistics, described in [Statistics Information on page 83](#)
- CellView global settings, described in [Global Settings on page 102](#)



NOTE

For adapters that include one or more ATM PMC daughtercards, *adapter* refers to each daughtercard.

CellView Features

CellView enables you to:

- Configure primary and backup functions for adapters
- Configure adapters to support either SONET or SDH framing standards and use a VPI other than 0
- Configure adapters to use a specific version of UNI signaling or to use the highest version available to both the system and the ATM switch
- Enable, disable, and configure up to 16 LAN Emulation Clients (LECs) and one Classical IP-over-ATM (CIP) client per adapter
- Enable, disable, and configure up to 16 LAN Emulation Servers (LEs) and one CIP ARP server per adapter
- Enable, disable, and configure one LAN Emulation Configuration Server (LECS) per adapter

- Set up Permanent Virtual Circuit (PVC) communications with other end stations
- Specify that direct Virtual Circuit (VC) connections between end stations not be released if LANE services are lost
- Display operating statistics for:
 - SONET, signaling, and cell-level activity
 - ATM Adaptation Layer 5 (AAL5) activity
 - LEC membership and activity
 - MPOA activity
 - LES activity
 - LECS activity
 - CIP activity

Before You Start

At least one client must be enabled and fully configured to run network applications on the end station. The degree of configuration needed for adapters depends on whether network services are installed. For example, if the LECS, LESs, and ARP server are already running on the network, you only need to enable and configure local clients on the adapter.

Before beginning CellView configuration, make sure of the following:

- At least one adapter is installed in the end station.
- The appropriate adapter driver is installed.
- At least one LEC or CIP client is installed with the driver (and enabled at driver initialization).
- The machine was rebooted after driver installation.

If these tasks are not complete, complete them now. See the appropriate chapter(s) for instructions.

Also do the following:

- Gather ATM address information for the adapter, as described in the next topic, [ATM Address](#).
- If the system includes a backup adapter, read over the information in [Redundant Link Support on page 55](#).
- If you are unfamiliar with how LEC-to-ELAN connections are managed by LES and LECS servers, read over the information in [LES and LECS Functions on page 56](#).

ATM Address

During configuration, you will need to know the end station's unique ATM address, which consists of the Network Prefix and ESI/Selector values. The full 20-byte ATM address and its separate components are shown in [Figure 8-1](#).

Figure 8-1. ATM Address

The **Network Prefix** is the 13-byte link address of the adapter, as set by the ATM switch.

The 7 byte **ESI/Selector** consists of a unique End Station Identifier (ESI) and a pointer (selector) with the following values:

- The ESI value is the 6-byte MAC address of the adapter (*00:00:77:86:da:61* in the example).
- The Selector value is a 1-byte pointer to clients and services located in the end station (*00* in the example).

The Selector value for the end station is always 00. The Selector values for the clients and services located in the end station are as follows:

Item Number	Selector Value Range
LEC1–LEC16	0x00–0x0f
LES1–LES16	0x20–0x2f
BUS1–BUS16	0x40–0x4f

Redundant Link Support

Redundant link support provides systems with high network availability. Using CellView, you can designate a backup adapter for one adapter or for multiple adapters of the same board type with similar configurations (such as the same chipset, control RAM, and reassembly RAM).

After primary and backup adapters are configured and the system is running, the driver monitors the status of each data link. If the driver detects a link failure in a primary adapter, it effects a fail-over. That is, the driver finds the backup adapter designated for that link. If the backup is available, the driver assigns it the clients and services of the failed primary adapter, and activates the backup. This switch is transparent to end-users and upper networking layers such as TCP/IP, ensuring no significant downtime.

In addition to making backup adapter assignments, you can use CellView to monitor the link status of primary and backup adapters. You can deactivate a primary adapter so that its backup adapter takes over, or reactivate a primary adapter after a fail-over.

LES and LECS Functions

To communicate on an ATM network, an LEC must join an emulated LAN (ELAN). The ELAN consists of a group of end stations that communicate among themselves with the same MTU size, the same frame format, and the same broadcast/multicast services.

The LAN Emulation Server (LES) is the central server for an ELAN. The LES provides address registration, address resolution, and broadcast services for all ELAN members. The driver allows up to 16 LESs to be enabled per adapter at one time (allowing support for up to 16 ELANs).

The LAN Emulation Configuration Server (LECS) serves LESs by managing which LEC joins which LES. The LECS provides a central point of contact on the network for LECs and LESs. During the boot process, the LEC sends the LECS a request for the type of ELAN it wants to join. The LECS responds with the current ATM address and configuration parameters of the LES that serves the requested ELAN.

When setting up LAN Emulation Servers and LAN Emulation Configuration Servers, keep in mind that each LECS must reside on the same ATM adapter as the LESs it serves. The LECS cannot communicate with LESs across the network.

Starting CellView

The following table describes the procedure to start CellView for each supported operating system.

Operating System	CellView Startup Procedure
Windows	Select Start . Select Settings . Select Control Panel . Double-click the CellView icon.
Solaris	At the system prompt, enter the command cellview
HP-UX	At the system prompt, enter the command cellview

When you start CellView, the main CellView dialog box appears.

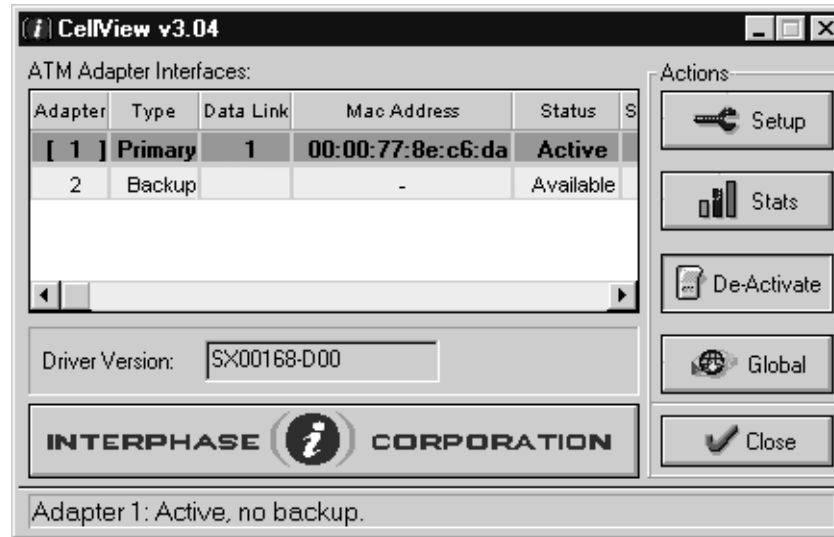

Figure 8-2. Main CellView Dialog Box

**NOTE**

On different operating systems, CellView dialog boxes appear slightly different. However, the functions are the same. For example, one system might provide a button to enable a setting where another system provides a checkbox.

CellView Adapter Interfaces and Actions

The fields in the main CellView dialog box display information about the Interphase ATM adapters installed in the system. The following table describes the fields.

This field...	Provides the following information...
Adapter	Adapter number, from 1 through 8.
Type	Type of adapter: primary or backup.
Data Link	Active data link number. This is the number of the primary adapter for which cells are being transferred. For an active primary adapter, this field displays the adapter number. It is blank if the primary adapter is inactive or down. For an active backup adapter, this field displays the number of the primary adapter being backed up. It is blank if the backup adapter is available (not active) or down.

This field...	Provides the following information...
MAC Address	<p>MAC address of the primary adapter for which cells are transferred.</p> <p>An active backup adapter uses the MAC address of the primary adapter number being backed up.</p> <p>This field is blank if the adapter is inactive.</p>
Status	<p>Connection status of the adapter.</p> <ul style="list-style-type: none"> • <i>Active</i> means the primary or backup adapter is active and transferring data. • <i>Down</i> means the primary or backup adapter has experienced a failure. • <i>Inactive</i> applies to primary adapters only. It means that the adapter has a good connection, but it is not active for data transfer. • <i>Available</i> applies to backup adapters only. It means that the adapter is not active, but is available to transfer data.
Switch Config	<p>Method for switching the data link from the backup adapter back to the primary adapter after a link failure is resolved. (This mode is set using the automatic switch-back setting on the Physical dialog box.)</p> <ul style="list-style-type: none"> • <i>Auto</i> indicates that the driver will automatically switch the data link to the primary adapter after link failure resolution. • <i>Manual</i> indicates that the end-user must switch the data link to the primary adapter after link failure resolution (by using the Activate button).
Driver Version	Version number of the ATM PCI driver used by the adapters.

The buttons on the CellView dialog box enable you to perform actions that affect the listed adapters or the CellView utility. The following table describes each action button function:

Click this button...	To do the following...
Setup	<p>Configure the following features for a selected adapter:</p> <ul style="list-style-type: none"> • Physical features, such as framing, ATM VPI number, and redundancy • signaling • LECs • LESs on the same adapter as the LECS • LECS on the same adapter as the LESs • CIP client and ARP server

Click this button...	To do the following...
Stats	<p>Display the status of the following operations for a selected adapter:</p> <ul style="list-style-type: none"> • signaling • AAL5 activity • LEC activity • Multi-Protocol Over ATM (MPOA) activity • LES activity • LECS activity • CIP client and ARP server activity
De-Activate/Activate	<p>This button appears only when multiple adapters are installed, with one assigned as a backup. It appears as De-Activate when an active primary or backup adapter is selected. It appears as Activate when an inactive primary adapter is selected.</p> <p>Use this button to do the following:</p> <ul style="list-style-type: none"> • Manually deactivate an active primary adapter and activate the assigned backup. • Manually activate an inactive primary adapter and deactivate the assigned backup. • Manually deactivate a backup adapter and reactivate the primary adapter.
Global	<p>Configure or view the following global CellView parameters:</p> <ul style="list-style-type: none"> • Application parameters for Setup and Statistics • Connection limits for end stations • Debugging message (to enable tracking of API, signaling, ILMI)
Close	Exit CellView

Setting Up ATM Network Services

Use CellView Setup tasks to configure ATM network services for the adapter. For primary adapters, you can configure settings for framing, redundancy, Virtual Path Identifier (VPI) address, signaling, clients, and servers. For backup adapters, you can configure framing and redundancy settings. When a backup adapter is activated, it inherits the remaining settings from the primary adapter it replaces.

You can configure up to 16 LECs and one CIP client on each primary adapter. The number of clients is specified during driver installation. (If you need to add additional clients, repeat the driver installation or configuration as instructed in the driver installation chapter for your system.)

You can also configure one LECS and up to 16 LESs on each primary adapter. If you plan to enable the LECS and LESs, it is recommended that you configure them before configuring clients.

The following is a configuration overview. The topics in this section provide detailed information about each step.

1. On the main CellView dialog box, select the adapter to configure, and click **Setup**.
2. Use the Physical dialog box to ensure that the adapter's physical settings are correct. (See [Setting Up Physical Features on page 60](#) for instructions.)
3. Use the signaling dialog box to ensure that signaling parameters conform to your ATM switch. (See [Setting Up UNI signaling on page 62](#) for instructions.)
4. If the LES(s) and LECS will be on this machine, use the LES and LECS dialog boxes to configure these servers. Enable advanced settings in the Global Application dialog box to make these dialog boxes available. (See [Setting Up a LAN Emulation Server on page 73](#) and [Setting Up a LAN Emulation Configuration Server on page 77](#) for instructions.)
5. Use the LEC dialog box to configure the LECs specified for the adapter during driver installation. (See [Setting Up LAN Emulation Clients on page 65](#) for instructions.)
6. Use the CIP dialog box to configure the CIP client and ARP server, if specified during driver installation. (See [Setting Up a CIP Client and Server on page 79](#) for instructions.)
7. Exit CellView Setup.

When you exit CellView, your changes are saved in a system configuration file on your hard disk.

If you change an adapter's primary or backup assignment, or if you change signaling parameters, you must restart the machine to make the change take effect. (On UNIX systems, you can restart signaling without rebooting the machine, as described in step 3 on page 64.) All changes other than redundancy and signaling are dynamic when you exit Setup.

Setting Up Physical Features

Use the Physical dialog box to set up the adapter's physical features, such as its framing type, VPI number, redundancy features, MAC address, and interrupt level.

To set up the adapter's physical features:

1. On the main CellView dialog box, highlight the adapter and click **Setup** to display the Physical dialog box.

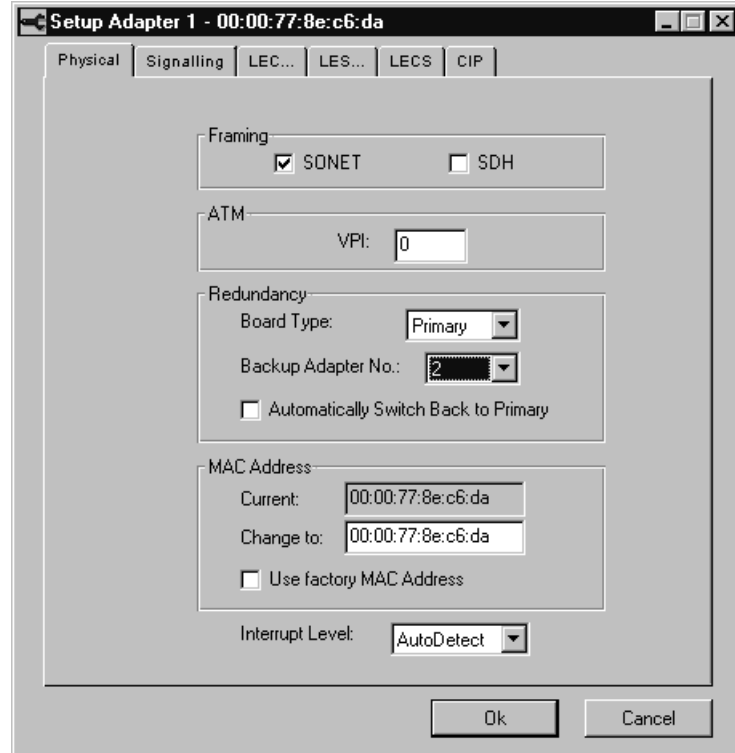

Figure 8-3. Physical Setup

2. Provide physical information as follows:

Use this field...	To do this...
-------------------	---------------

Framing	<p>Select the appropriate Framing method:</p> <ul style="list-style-type: none"> • Select SONET (Synchronous Optical Network) to use the North American multiplexing standard to define the signal used in optical fiber networks. This option is the default. <p>For ATM over fiber, OC-3c, with a base rate of 155.520 Mbps, is the most widely-used signal in the United States.</p> <ul style="list-style-type: none"> • Select SDH (Synchronous Digital Hierarchy) to use the European multiplexing standard to define the signal used in optical fiber networks. <p>STM-1 (Synchronous Transport Mode, Level 1) is the European equivalent of OC-3c. Like OC-3c, STM-1 has a base rate of 155 Mbps, but STM-1 has slightly different framing information.</p>
ATM: VPI	<p>Identify the default Virtual Path Identifier to be used by all services on the adapter. The VPI is a one-byte field in the ATM cell header that, combined with the Virtual Circuit Identifier (VCI), forms an ATM address.</p> <p>You can enter a number from 0 (the default) to 255.</p>

Use this field...	To do this...
Redundancy: Board Type	Designate the adapter as primary or backup. Adapter 1 must be a primary adapter. Adapters 2–8 can be primary or backup. For guidelines, see Redundant Link Support on page 55 .
Redundancy: Backup Adapter No.	For a primary adapter, designate the backup adapter number. The value can be <i>none</i> or any backup adapter number between 2 and 8. For guidelines, see Redundant Link Support on page 55 .
Automatically Switch Back to Primary	For a primary adapter, have the driver automatically reactivate the adapter and deactivate its backup after a failure condition is resolved.
MAC Address: Current	View the currently assigned MAC address of the adapter.
MAC Address: Change to	Change the adapter's MAC address to the one entered here.
MAC Address: Use factory MAC address	Use the MAC address originally assigned to the adapter by Interphase.
Interrupt Level (Windows NT only)	Set the adapter's PCI interrupt value. The default AutoDetect setting is recommended. If the driver fails to recognize the adapter with AutoDetect set, select the appropriate interrupt level.

3. If you changed any redundancy settings, reboot your system to make the changes take effect.

Setting Up UNI signaling

The driver is designed to operate with the UNI 3.0, 3.1, and 4.0 signaling specifications. The driver uses ATM's Integrated Local Management Interface (ILMI). ILMI enables the system to query the ATM switch at startup and synchronize to the highest signaling revision available to both the system and the switch. You can configure the adapter to use the ILMI auto-synchronization (default), or to use a specific UNI version.

To set up UNI signaling parameters:

1. On the main CellView dialog box, highlight the adapter and click **Setup**. Then select the **signaling** tab to display the signaling dialog box.

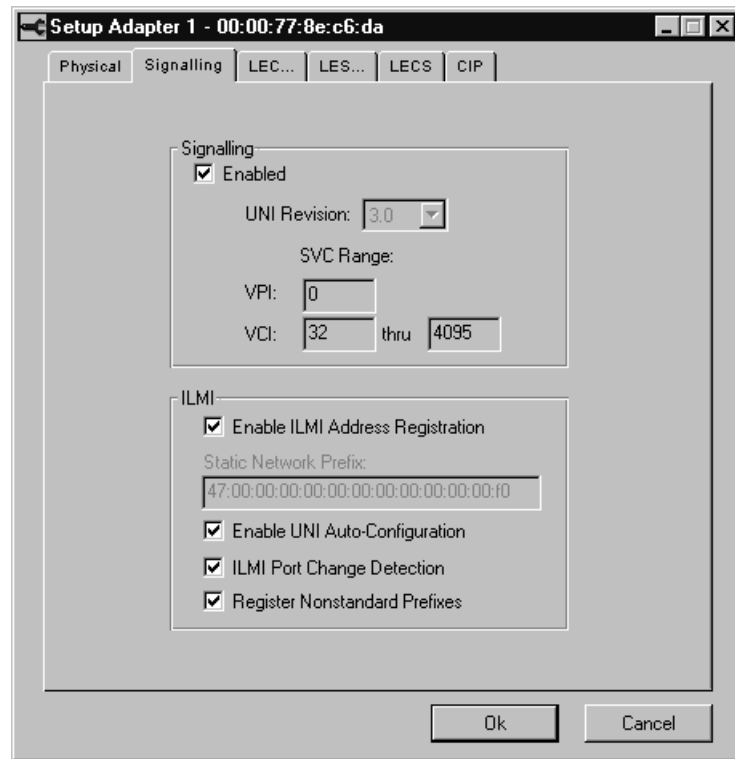

Figure 8-4. signaling Setup

2. Provide signaling information as follows:

Use this field...	To do this...
Enabled	Enable UNI signaling. UNI signaling is required for Switched Virtual Circuit (SVC) connections but not for PVC connections.
UNI Revision	Specify that the adapter always use either UNI 3.0, UNI 3.1, or UNI 4.0 signaling. Unavailable if UNI Auto-Configuration is enabled.
SVC Range: VPI (Virtual Path Identifier)	View the Virtual Path Identifier available to the driver for SVCs. This is the VPI number entered on the Physical dialog box (as described in Setting Up Physical Features on page 60).
SVC Range: VCI (Virtual Circuit Identifier)	View the range of Virtual Circuit Identifiers available to the driver for SVCs. The range is fixed and cannot be edited. Circuits 0–31 are reserved for system communications. The following circuits are available for station-to-station traffic. <ul style="list-style-type: none"> • Circuits 32–1023 on 1K VC adapters • Circuits 32–4095 on 4K VC adapters

Use this field...	To do this...
ILMI: Enable ILMI Address Registration	<p>Enable the adapter to acquire its 13-byte network prefix at boot time from the switch.</p> <p>Disable this feature if your switch does not support address registration.</p>
Static Network Prefix	<p>View or enter the adapter's 13-byte network prefix.</p> <p>If the ILMI Address Registration feature is enabled, the network prefix is entered automatically during the boot process.</p> <p>If the Enable Address Registration feature is disabled, obtain the network prefix from the switch and enter it manually.</p>
Enable UNI Auto- Configuration	<p>Enable the adapter to negotiate with the switch for the highest possible UNI revision (including UNI 3.0, 3.1, or 4.0). This setting is enabled by default. When enabled, it overrides the UNI Revision selection field.</p> <p>This field is available only if the ILMI Address Registration feature is enabled.</p>
ILMI Port Change Detection	<p>Enable the adapter to poll the ATM switch every 30 seconds, to advise that it is up and running.</p> <p>During the boot process, the switch adds the host station to the active stations list. If the host station is turned off, polling stops, and the switch removes the host from this list.</p> <p>This field is available only if the ILMI Address Registration feature is enabled.</p> <p>Disable this feature if your switch does not support ILMI polling.</p>
Register Nonstandard Prefixes	<p>Enable the ILMI to register the ATM Forum's well-known address for the LECS with the switch.</p> <p>The prefix in the well-known address usually differs from the ATM prefix for the adapter.</p> <p>Some switches might not support the registration of different prefixes through a single port. Disable this setting if your switch does not support mixed prefixes.</p> <p>This field is available only if the ILMI Address Registration feature is enabled.</p>

3. Restart signaling to make changes take effect:

- On Windows systems, restart signaling by rebooting your system.
- On UNIX systems, restart signaling with the command **restart_signald**

Setting Up LAN Emulation Clients

CellView provides a separate tabbed dialog box to set up each LEC initialized during driver installation. You can configure each LEC to establish SVC communications at during the boot process via an LECS or an LES. You can also set up PVC links with other end stations.

To join an emulated LAN (ELAN), a LEC must contact an LES, which manages a specific ELAN's client connections. You can configure the LEC to directly contact an LES or to be routed to an appropriate LES through the LECS, which assigns LECs to LESs based on ELAN request parameters.

If the LESs and LECS will reside on the adapter, configure them before the LEC. For instructions, see [Setting Up a LAN Emulation Server on page 73](#) and [Setting Up a LAN Emulation Configuration Server on page 77](#). (For general information about the LES and LECS servers, see [LES and LECS Functions on page 56](#).)

To set up an LEC:

1. On the main CellView dialog box, highlight the adapter and click **Setup**. Then select the **LEC...** tab.
2. If the multiple LECs are on the adapter, select the number of the LEC you are configuring to display the appropriate LEC dialog box.

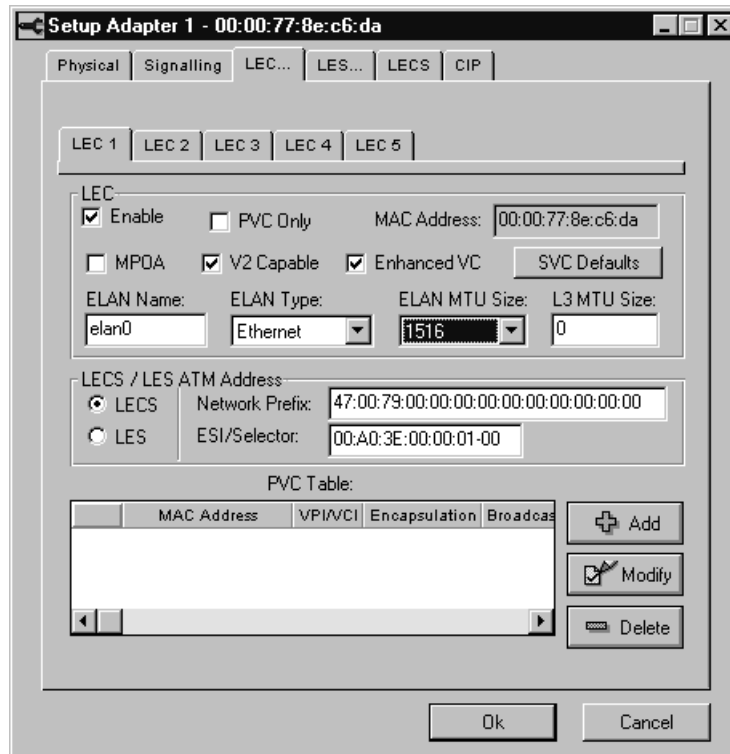

Figure 8-5. LEC Setup

3. Enter information to configure the following:
 - Network settings, as described in the next topic, [LEC and LECS/LES ATM Address Settings](#)
 - Default settings for client SVCs, as described in [SVC Default Settings](#) on page 69
 - Client PVC settings, as described in [LEC PVC Settings](#) on page 70

LEC and LECS/LES ATM Address Settings

To configure LEC network settings, provide client and network information as follows:

Use this field...	To do this...
Enable	Enable the LEC.
PVC Only	<p>Enable PVC-only activity for the client (and disable SVC activity).</p> <p>If you enable PVC-only activity, set up the PVC table as described in Adding or Modifying LEC PVC Entries on page 71. For PVC-only clients, the only other available setting is the L3MTU Size.</p>
MAC Address	View the MAC address of the LEC. LEC 1 is assigned the base address of the adapter. The remaining LECs use increments of the base address for their MAC addresses.
MPOA	<p>Enable Multi-protocol over ATM support. (Not available for Token Ring ELAN type.)</p> <p>MPOA is an ATM Forum standard that provides routing of legacy internetwork layer protocols (such as IP, IPX, and AppleTalk) over ATM networks. MPOA allows LANE edge devices to perform internetwork layer forwarding and establish direct communications without requiring that LANE edge devices be full function routers. It separates the internetwork routing processing from the actual forwarding. (For additional information about MPOA, see MPOA Statistics on page 90.)</p> <p>If MPOA is enabled, the V2 Capable property is automatically enabled; MPOA requires a LANE implementation that meets the minimal requirements of the <i>LAN Emulation Over ATM Version 2</i> specification.</p>
V2 Capable	<p>Specify that the LEC use SVCs in compliance with the <i>LAN Emulation Over ATM Version 2</i> specification. Requires a LANE implementation that meets the minimal requirements of the specification.</p> <p>If the LEC will use ABR connections or the MPOA protocol, this property must be enabled.</p>

Use this field...	To do this...
Enhanced VC	<p>Specify whether the network should maintain current, dynamic data VCs if the connection to the LES that established the VC links is lost.</p> <ul style="list-style-type: none"> • When enabled, any established, dynamic data VC links are maintained if the LES becomes inactive. • When disabled, any established, dynamic data VC links are torn down if the LES connection is lost.
ELAN Name	<p>Identify the network name of the emulated LAN you want the client to join.</p> <p>Some LAN emulation servers require a name while others do not. The Interphase LECS and LESs require a name only in the following cases:</p> <ul style="list-style-type: none"> • The Strict ELAN Name field is enabled on the LES dialog box. (For information about LES setup, see Setting Up a LAN Emulation Server on page 73.) • You need to differentiate between two or more LESs with the same ELAN type and MTU size. <p>For exact requirements, see your server documentation.</p>
ELAN Type	<p>Select the ELAN type (Ethernet or Token Ring).</p>
ELAN MTU Size	<p>Select the ELAN MTU size to request. The client uses this entry when making a request to join an LES. The MTU returned to the client is equal to or less than the requested value.</p> <ul style="list-style-type: none"> • For an ELAN with Ethernet edge device, select 1516 • For an ELAN with Ethernet edge device and with MPOA enabled, select 1580 • For an ELAN with Token Ring edge device at 4 Mbps operation, select 4544 • For an ELAN with ATM end stations only, select 9234 • For an ELAN with Token Ring edge device at 16 Mbps operation, select 18190 <p>All nodes on the same logical subnet must use the same MTU size.</p>

Use this field...	To do this...
L3MTU Size	<p>Force the MTU size to the entered value, rather than the value returned by the LES. Done only for values other than zero (0).</p> <p>If the MTU is not based on the MAC layer, you must set the L3MTU size to the actual IP MTU of the network. For example, if the ELAN MTU Size of a Token Ring network is 4544, but the IP MTU is 2048, set the L3MTU Size to 2048.</p> <p>NOTE: If the client is in PVC-only mode (no LAN Emulation services), set the L3MTU size to the IP MTU of the network. For a PVC-only client, you must also set up the PVC table as described in Adding or Modifying LEC PVC Entries on page 71.</p>
LECS/LES ATM Address: LECS and LES	<p>Each LEC that uses SVC communications connects to other clients via an LES. This option controls whether the LEC contacts the LES at startup directly or through the LECS.</p> <ul style="list-style-type: none"> • Select LES to have the client contact the LES directly <p>OR</p> <ul style="list-style-type: none"> • Select LECS to have the client contact the LECS, which will route the LEC to the appropriate LES.
LECS/LES ATM Address: Network Prefix and ESI/Selector	<p>Use these fields together to identify the full ATM address of the LES or LECS to be contacted by the LEC at startup.</p> <ul style="list-style-type: none"> • If the LEC will contact the LECS at startup, the entry defaults to the ATM Forum's well-known address. If you need to change the address, enter the ATM address of the LECS in the Network Prefix and ESI/Selector fields. • If the LEC will contact the LES directly, enter the LES's ATM address. (The address is predetermined for the LES, usually as part of the switch setup.) <p>(For details about the address structure, see ATM Address on page 54. For information about LES and LECS setup, see Setting Up a LAN Emulation Server on page 73 and Setting Up a LAN Emulation Configuration Server on page 77.)</p>

SVC Default Settings

To view or change the default settings for all SVCs used by the LEC, click the **SVC Defaults** button in the LEC section of the LEC dialog box. This button opens the LEC Default Settings dialog box.

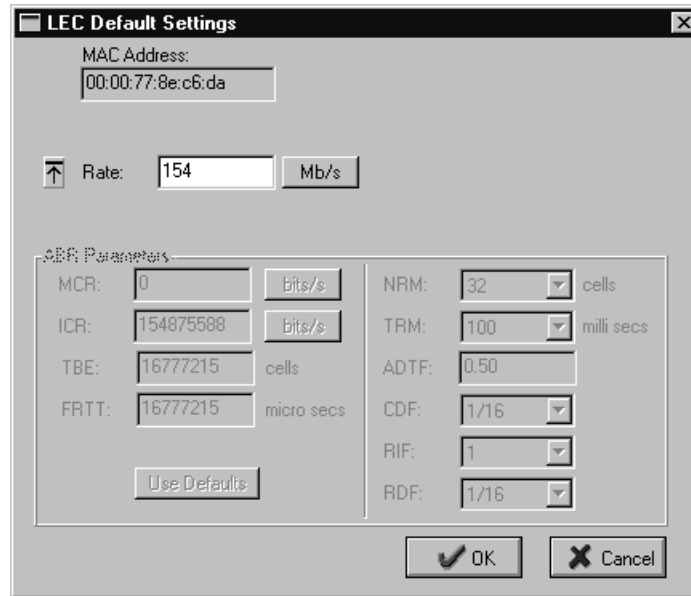

Figure 8-6. LEC Default Settings



NOTE

For ABR configuration, the adapter must support ABR service, and the LEC's LANE V2 Capable property must be enabled.

To configure cell rate parameters for all SVCs on the client, provide LEC default settings information as follows:

Use this field...	To do this...
MAC Address	View the MAC address of the LEC.
Rate	<p>Set the cell rate to use as the default for SVC traffic on the LEC.</p> <ul style="list-style-type: none"> Use the arrow button to select the maximum rate available for the measurement unit. Use the entry field to enter a specific cell rate. Use the button at the right of the entry field to select a unit of cells per second, kilobits per second, megabits per second, or bits per second.

Use this field...	To do this...
MCR	For an adapter with Available Bit Rate (ABR) support, specify the Minimum Cell Rate in cells per second, kilobits per second, megabits per second, or bits per second.
ICR	For an adapter with ABR support, specify the Initial Cell Rate in cells per second, kilobits per second, megabits per second, or bits per second.
TBE	For an adapter with ABR support, specify the number of cells to use as the Transient Buffer Exposure.
FRTT	For an adapter with ABR support, specify the Fixed Round Trip Time in micro seconds.
NRM	For an adapter with ABR support, specify the maximum Number of cells for each forward RM Cell.
TRM	For an adapter with ABR support, specify the Time between forward RM Cells in milli-seconds.
ADTF	For an adapter with ABR support, specify, the Allowed Cell Rate (ACR) Decrease Time Factor.
CDF	For an adapter with ABR support, select the Cutoff Decrease Factor.
RIF	For an adapter with ABR support, select the Rate Increment Factor.
RDF	For an adapter with ABR support, select the Rate Decrement Factor.

LEC PVC Settings

Use the PVC Table in the LEC dialog box to set up PVC connections between an LEC and other network end stations. The following figure illustrates the PVC Table for LECs.

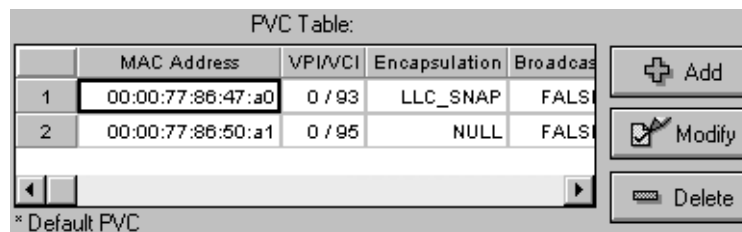

Figure 8-7. PVC Table in LEC Dialog Box

A 6-byte MAC address and a VPI/VCI number are associated with each PVC. Packets from the upper layers whose destination MAC addresses match an address in the PVC table are transmitted on that PVC.

In addition to providing setup information in the PVC Table, you must also consider the following when configuring PVCs:

- All PVCs must be configured in the adapters and the switch(es) manually.

- The MAC address of the target station must be mapped to a VCI in the local host.
- The MAC address of the local client must be mapped to a VCI in the target station.

You can use buttons in the PVC table box to add, modify, or delete PVC table entries, as described in the topics that follow.

Adding or Modifying LEC PVC Entries

To add or modify PVCs for the LEC:

1. Click **Add**, or highlight the appropriate entry and click **Modify**.

The following dialog box appears:

Figure 8-8. PVC Settings for LECs



NOTE

For ABR configuration, the adapter must support ABR and the LEC's LANE V2 property must be enabled.

2. Provide PVC settings information as follows:

Use this field...	To do this...
MAC Address	Enter the 6-byte address of the target station to which the PVC will connect. Use the natural format for the ELAN. For example, for a Token Ring ELAN, use non-canonical format.

Use this field...	To do this...
VCI	<p>Enter the VCI number to be used by the LEC to communicate with the target.</p> <p>To determine the available VCIs, go to the signaling setup dialog box and check the SVC Range in the VCI fields (Figure 8-4 on page 63).</p> <p>In most cases, the range is 32–1023 for 1K VC adapters, or 32–4095 for 4K VC adapters.</p> <p>(The corresponding VPI is configured on the Physical setup dialog box, as described in Setting Up Physical Features on page 60.)</p>
Rate	<p>Set the cell rate to use for the PVC traffic.</p> <ul style="list-style-type: none"> • Use the arrow button to select the maximum rate available for the measurement unit. • Use the entry field to enter a specific cell rate. • Use the button at the right of the entry field to select a unit of cells per second, kilobits per second, megabits per second, or bits per second.
Service	<p>Select UBR or ABR service. ABR is available only if it is supported by the adapter.</p>
Encapsulation	<p>Select the encapsulation method (LLC_Snap or Null). The host and target must use the same encapsulation method. See Multiprotocol Encapsulation over ATM AAL5 on page 274 for an explanation of encapsulation methods.</p>
Broadcast	<p>Enable the entry as a Broadcast PVC.</p> <p>If enabled, all broadcast/multicast packets from the upper layers are transmitted on this PVC. A maximum of 16 Broadcast PVCs can be enabled on each LEC.</p>
Default PVC	<p>Enable the PVC to get packets for unknown MAC addresses. Available when the LEC is in PVC-only mode.</p>
MCR	<p>For an adapter with ABR support, specify the Minimum Cell Rate in cells per second, kilobits per second, megabits per second, or bits per second.</p>
ICR	<p>For an adapter with ABR support, specify the Initial Cell Rate in cells per second, kilobits per second, megabits per second, or bits per second.</p>
TBE	<p>For an adapter with ABR support, specify the number of cells to use as the Transient Buffer Exposure.</p>
FRTT	<p>For an adapter with ABR support, specify the Fixed Round Trip Time in micro seconds.</p>
NRM	<p>For an adapter with ABR support, specify the maximum Number of cells for each forward RM Cell.</p>

Use this field...	To do this...
TRM	For an adapter with ABR support, specify the Time between forward RM Cells in milli-seconds.
ADTF	For an adapter with ABR support, specify, the Allowed Cell Rate (ACR) Decrease Time Factor.
CDF	For an adapter with ABR support, select the Cutoff Decrease Factor.
RIF	For an adapter with ABR support, select the Rate Increment Factor.
RDF	For an adapter with ABR support, select the Rate Decrement Factor.

Deleting LEC PVC Entries

To delete a PVC, highlight the entry in the PVC Table on the LEC dialog box and click **Delete**.

Setting Up a LAN Emulation Server

A LAN Emulation Server (LES) is the central server for an associated ELAN. The LES provides address registration, address resolution, and broadcast services for all ELAN members. When a LEC joins an LES, the client's MAC-ATM address relationship is registered with the LES. The LES maintains a running account of these addresses to resolve ELAN members' queries. The connection between the LES and the LEC is a permanent, open one as long as the client is running.

The LES maintains a table of client information to provide ELAN address resolution services. When an end station is disconnected or turned off, the LES automatically removes clients from the table. Therefore, relocating an end station only involves physically moving the hardware and connecting it to the same or another ATM switch. During the boot process, the clients rejoin the LES with a new ATM address.

CellView provides a separate tabbed LES dialog box for each LES-ELAN setup. To set up an LES:

1. To make the **LES** tab available, click **Global** on the main CellView dialog box. Then on the Application dialog box, check the **Enable Advanced Settings** field and click **OK**.
2. On the main CellView dialog box, highlight the adapter and click **Setup**. Then select the **LES...** tab.
3. If multiple LESs are on the adapter, select the number of the LES you are configuring to display the appropriate LES dialog box.

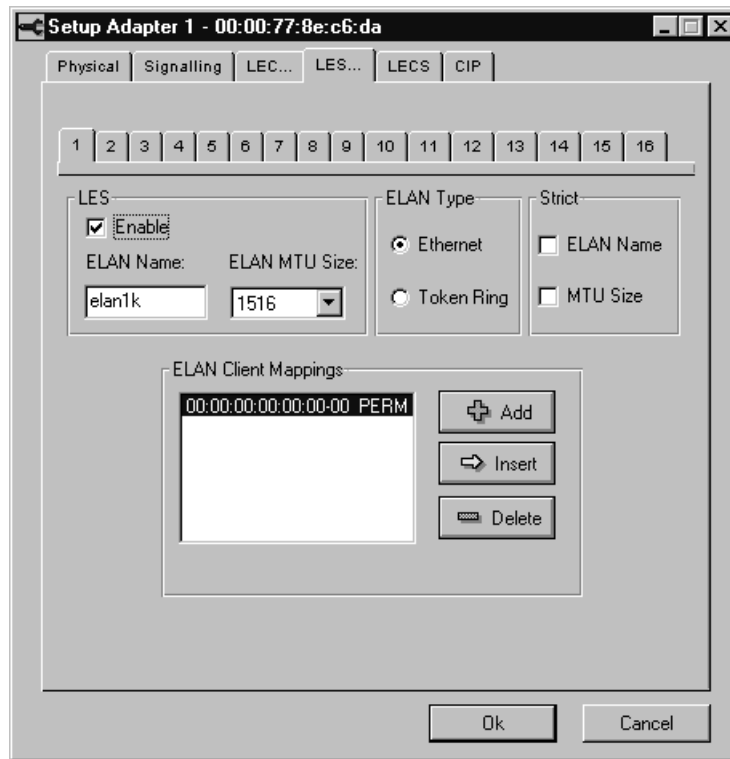

Figure 8-9. LES Setup

4. Enter LES information to configure the following:
 - LES and ELAN network settings, as described in the next topic, [LES Network Settings](#)
 - ELAN client mapping settings, as described in [ELAN Client Mappings Settings](#) on page 75

LES Network Settings

To configure LES network settings, provide LES and ELAN information as follows:

Use this field...	To do this...
Enable	Enable the LES.
ELAN Name	Enter the name of the ELAN for which the LES provides services (not required for an LEC to join the group, but may be needed if an LEC is to request this ELAN among a group of similarly configured ELANs). If the ELAN Name setting in the Strict box is enabled, the ELAN name in a LEC request must exactly match this name (case-sensitive) for the LEC to join the group.

Use this field...	To do this...
ELAN MTU Size	Select the MTU size of the ELAN for which the LES provides services. Options are: <ul style="list-style-type: none"> • For an ELAN with Ethernet edge device: 1516 • For an ELAN with Ethernet edge device and with MPOA enabled: 1580 • For an ELAN with Token Ring edge device at 4 Mbps: 4544 • For an ELAN with ATM end stations only: 9234 • For an ELAN with Token Ring edge device at 16 Mbps operation: 18190
ELAN Type	Select the ELAN type (Ethernet or Token Ring) to use for all communications between end stations.
Strict: ELAN Name	Specify that the ELAN Name in the LEC's request must exactly match the entry in the ELAN Name field on this dialog box (case-sensitive).
Strict: MTU Size	Specify that the ELAN MTU Size in the LEC's request must exactly match the entry in the ELAN MTU Size field on this dialog box.

ELAN Client Mappings Settings

The ELAN Client Mappings table on the LES dialog box shows the ESI/Selector value for each LEC currently assigned to the LES. The following figure illustrates the ELAN Client Mappings table:

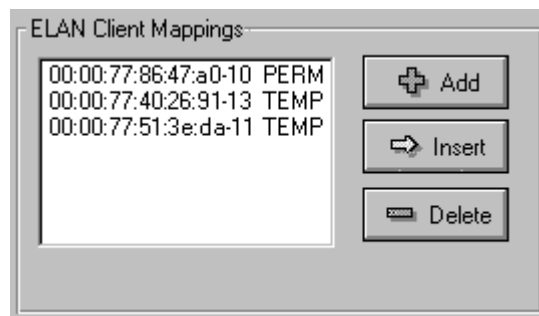

Figure 8-10. ELAN Client Mappings Table

LECs can be *permanently* or *temporarily* assigned to the LES, based on settings configured in the LES dialog box.

- **PERM** means the client is permanently assigned to the LES (using the Client Mappings **Add** or **Insert** button). A permanently-assigned client can join only its assigned LES. This gives network administrators control in assigning clients to specific ELANs.

- **TEMP** means the client is temporarily assigned to the LES based on the configuration parameters requested by the client in the LEC dialog box. This entry is removed when the client leaves the ELAN.

The ELAN Client Mappings table obtains the list of permanently-assigned clients from a table maintained by the LECS. When the LECS is enabled, it checks for permanent status each time a client attempts to join the network, regardless of whether the client is configured to contact the LECS or directly contact an LES.

Adding a Client that is not Assigned to an ELAN

If a client does not already belong to another network ELAN, use the **Add** button on the LES dialog box to assign the client to the LES. The Add procedure permanently adds the new client entry to the LES's ELAN Client Mappings table and removes the client from any other LES mappings.

To add a client to the LES:

1. Click **Add** to display the following dialog box.

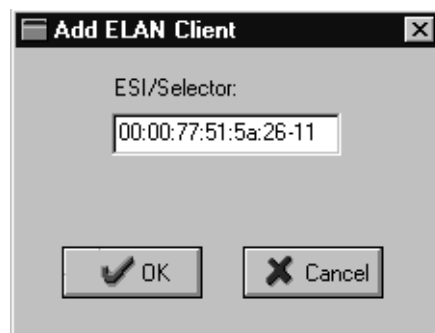

Figure 8-11. Add Permanent Clients to an LES

2. Enter the ESI/Selector value for the client.
If you are not familiar with the structure of this address, see [ATM Address on page 54](#).
3. Click **OK**.

Inserting Clients Assigned to Another ELAN

The **Insert** button provides a quick way to permanently assign one or more clients that are permanently or temporarily running on another network ELAN. Like Add, Insert permanently adds the new client entries to the LES's ELAN Client Mappings table and removes the clients from any other LES mappings.

To move clients to the LES from another network LES:

1. Click **Insert** to display the following dialog box.

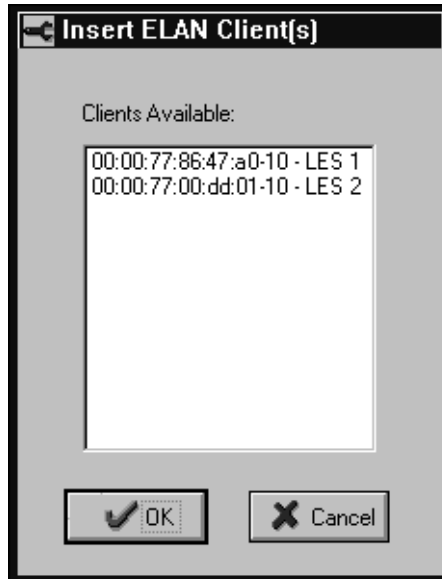

Figure 8-12. Insert Permanent Clients

The Clients Available list shows all clients, by ESI/Selector number, that are permanently or temporarily assigned to other network LESs.

2. Highlight the clients you want to assign to the LES being configured, and click **OK**.

Deleting a Client

To remove a client from the LES, highlight the client in the ELAN Client Mappings table and click **Delete**.

If the client was permanently assigned, it is removed from the ELAN served by the LES and from the table of permanent clients maintained by the LECS. It can attempt to join the network again any time after deletion.

If the client was temporarily assigned, it is removed from the ELAN served by the LES. When it attempts to join the network again, it will be assigned to an LES based on request parameters in the LEC Setup dialog box. (This will be the same LES unless changed in the LEC Setup dialog box after the last startup.)

Setting Up a LAN Emulation Configuration Server

The LAN Emulation Configuration Server (LECS) is a server that manages LESs on a network. The LECS manages which LEC joins which LES (which is the central server for an ELAN). The LECS provides a central point of contact for each LEC on the network. During the boot process, the LEC sends the LECS a request for the type of ELAN it wants to join. The LECS responds with the current ATM address and configuration parameters of the LES that serves the requested ELAN.

The LECS must reside on the ATM adapter with the LESs it serves; it cannot communicate with LESs across the network.

To set up the LECS:

1. To make the **LECS** tab available, click **Global** on the main CellView dialog box. Then on the Application dialog box, check the **Enable Advanced Settings** field and click **OK**.
2. On the main CellView dialog box, highlight the adapter and click **Setup**. Then select the **LECS** tab to display the LECS dialog box.

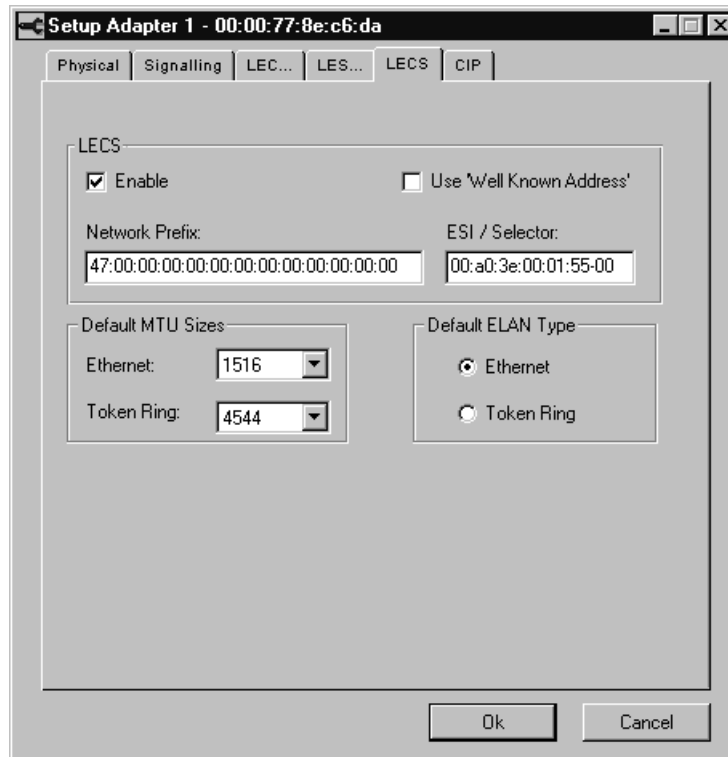

Figure 8-13. LECS Setup

3. Provide LECS information as follows:

Use this field...	To do this...
Enable	Enable the LECS and all permanent mappings of LECs to specific LESs.
Use 'Well Known Address'	Enable the ATM Forum's well-known address to be loaded to the Network Prefix and ESI/Selector fields as the LECS's ATM address. If enabled, the well-known address will override a manually entered Network Prefix and ESI/Selector address.

Use this field...	To do this...
Network Prefix and ESI Selector	If the LECS's ATM address differs from the ATM Forum's well-known address, enter the LECS's ATM Network Prefix and ESI/Selector values. (For details about the address structure, see ATM Address on page 54.)
Default MTU Sizes	Select the default Ethernet or Token Ring ELAN MTU size to assign to an LEC if the LEC's configuration request omits the MTU size (1516, 4544, 9234, 18190).
Default ELAN Type	Select a default ELAN type (Ethernet or Token Ring) to assign to an LEC if the LEC's configuration request omits the ELAN type.

Setting Up a CIP Client and Server

The CIP client conforms to the RFC 1577 specification using Classical IP-over-ATM where no multicast or broadcast services are available.

Using the CIP dialog box, you can enable the CIP client and enable the host adapter as the Address Resolution Protocol (ARP) server for the network. You can also set up PVC links between the CIP and other end stations.

To set up a CIP client/ARP server configuration:

1. On the main CellView dialog box, highlight the adapter and click **Setup**. Then select the **CIP** tab to display the CIP dialog box.

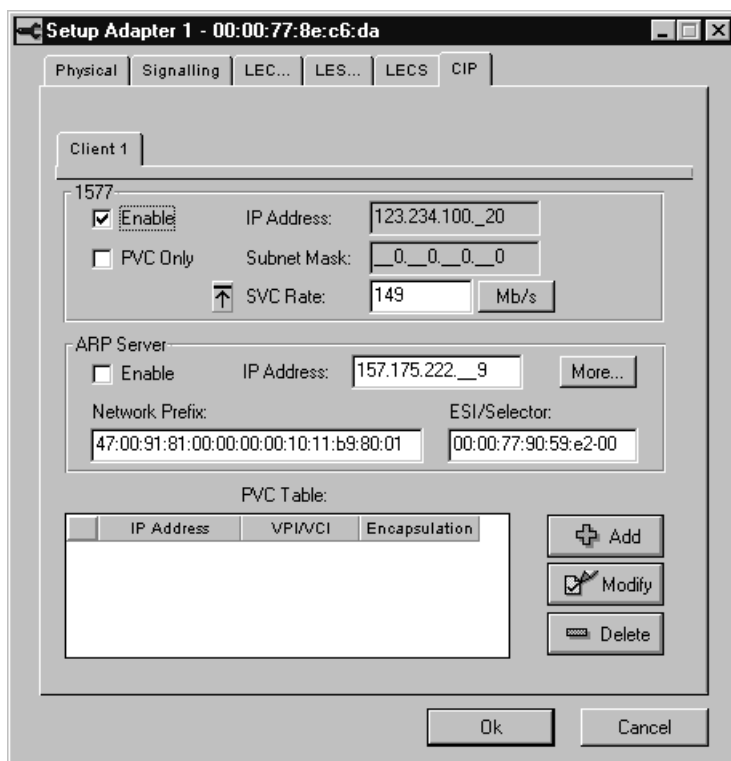

Figure 8-14. CIP Setup

2. Enter information in the CIP fields to configure the following:
 - Client and ARP server settings, as described in the next topic, *CIP Client and ARP Server Settings*
 - PVC settings, as described in *CIP PVC Settings on page 81*

CIP Client and ARP Server Settings

To configure CIP client and ARP server settings, provide CIP and ARP server network information as follows:

Use this field...	To do this...
Enable	Enable the CIP client.
PVC Only	Enable PVC-only activity for the client (and disable SVC activity). If you enable PVC-only activity, set up the PVC table as described in <i>CIP PVC Settings on page 81</i> . If this setting is enabled, ARP Server settings are unavailable.
IP Address	Enter the client's IP address.
Subnet Mask	Enter the client's subnet mask identifier.

Use this field...	To do this...
SVC Rate	<p>Set the cell rate to use as the default for SVC traffic.</p> <ul style="list-style-type: none"> Use the arrow button to select the maximum rate available for the measurement unit. Use the entry field to enter a specific cell rate. Use the button at the right of the entry field to select a unit of cells per second, kilobits per second, megabits per second, or bits per second.
ARP Server: Enable	<p>Enable the host adapter as the ARP server for your CIP network.</p> <p>If this setting is disabled, you can enter address, settings for an ARP server located elsewhere in the network.</p> <p>You can also click the More button if this setting is disabled to open the Classical IP ARP Servers dialog box, and add or modify the address settings for additional ARP servers.</p>
ARP Server: IP Address	<p>If the host adapter is not the ARP server, enter the IP address of the ARP server located elsewhere in the network.</p> <p>Click the More button to add or modify the IP address, Network Prefix, or ESI/Selector for other ARP servers.</p>
ARP Server: Network Prefix and ESI/Selector	<p>If the host adapter is not the ARP server, enter the ARP server's ATM address, which consists of the Network Prefix and ESI/Selector. (For details about the address structure, see ATM Address on page 54.)</p> <p>The CIP driver must know the ATM address of the ARP server. When the system is powered up, it calls the ARP server with this ATM address.</p> <p>Click the More button to add or modify the IP address, Network Prefix, or ESI/Selector for other ARP servers.</p>

CIP PVC Settings

Use the PVC Table in the CIP dialog box to set up PVC connections between the local CIP client and other network end stations. The following figure illustrates the PVC Table for CIP clients.

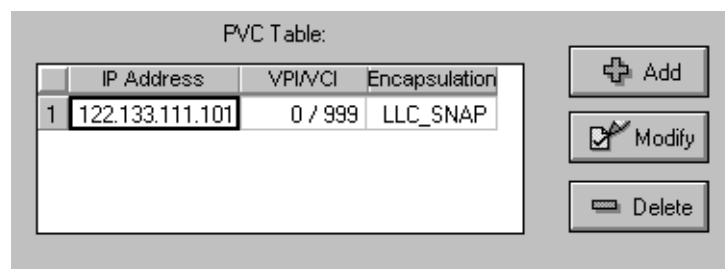

Figure 8-15. PVC Table in CIP Dialog Box

An IP address and VPI/VCI number are associated with each PVC. Packets from the upper layers whose destination addresses match an address in the PVC table are transmitted on that PVC.

In addition to providing setup information in the PVC Table, you must also consider the following when configuring PVCs for the CIP client:

- All PVCs must be configured in the adapters and the switch(es) manually.
- The IP address of the target station must be mapped to a VCI in the local host.
- The IP address of the local client must be mapped to a VCI in the target station.

You can use buttons in the PVC table box to add, modify, or delete PVC table entries, as described in the topics that follow.

Adding or Modifying CIP PVC Entries

To add or modify PVC table entries for a CIP client:

1. Click **Add**, or highlight the appropriate entry and click **Modify**.

The following dialog box appears:

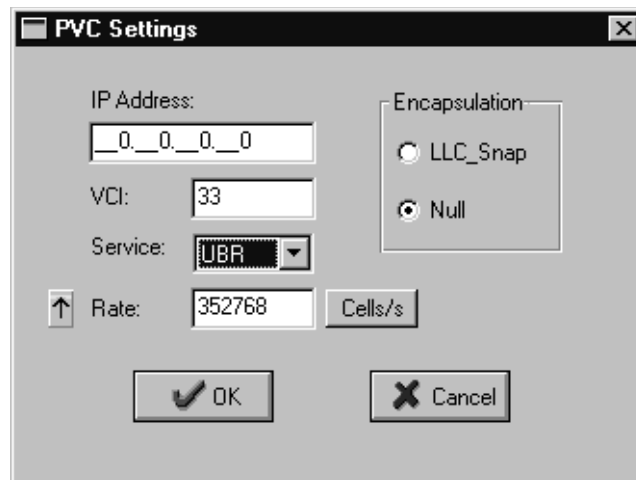

Figure 8-16. PVC Settings for CIP Clients

2. Provide PVC information as follows:

Use this field...	To do this...
IP Address	Enter the IP address of the target station to which the PVC will connect.

Use this field...	To do this...
VCI	<p>Enter the Virtual Circuit Identifier number to be used by the CIP client to communicate with the target.</p> <p>To determine the available VCIs, go to the signaling setup dialog box and check the SVC Range in the VCI fields (Figure 8-4 on page 63).</p> <p>In most cases, the range is 32–1023 for 1K VC adapters, or 32–4095 for 4K VC adapters.</p> <p>(The corresponding VPI is configured on the Physical setup dialog box, as described in Setting Up Physical Features on page 60.)</p>
Service	Select UBR or ABR service. ABR is available only if it is supported by the adapter.
Rate	<p>Set the cell rate to use for the PVC traffic.</p> <ul style="list-style-type: none"> • Use the arrow button to select the maximum rate available for the measurement unit. • Use the entry field to enter a specific cell rate. • Use the button at the right of the entry field to select a unit of cells per second, kilobits per second, megabits per second, or bits per second.
Encapsulation	<p>Select the encapsulation method (LLC_Snap or Null).</p> <p>The host and target must use the same encapsulation method. See Multiprotocol Encapsulation over ATM AAL5 on page 274 for an explanation of these encapsulation methods.</p>

Deleting CIP PVC Entries

To delete a PVC, highlight the entry in the PVC Table on the LEC dialog box and click **Delete**.

Statistics Information

The CellView Statistics function provides information that can help you troubleshoot network problems and check for proper driver operation. Statistics dialog boxes display network statistics for the clients and servers on the Interphase ATM adapter(s) installed in an end station. When the end station boots up, certain communications must occur between the client and the server (through the switch) so the client can log onto the network. Statistics routines monitor the state of client and server communications, signaling, and AAL5 traffic.

CellView gathers network operation statistics for local Interphase clients and servers only. It does not gather statistics from switches or from other end stations.

CellView provides the following sets of statistics:

- signaling, described in [signaling Statistics on page 84](#)

- AAL5, described in [AAL5 Statistics on page 86](#)
- LEC, described in [LEC Statistics on page 87](#)
- MPOA, described in [MPOA Statistics on page 90](#)
- LES, described in [LES Statistics on page 95](#)
- LECS, described in [LECS Statistics on page 97](#)
- CIP, described in [CIP Statistics on page 100](#)

If you find an item in error, the driver might be incorrectly installed or configured. If you suspect a problem with your driver setup, see [Troubleshooting on page 167](#).

signaling Statistics

To display statistics about the signaling on an adapter, on the main CellView dialog box, highlight the adapter and click **Stats**. The signaling Statistics dialog box is displayed.

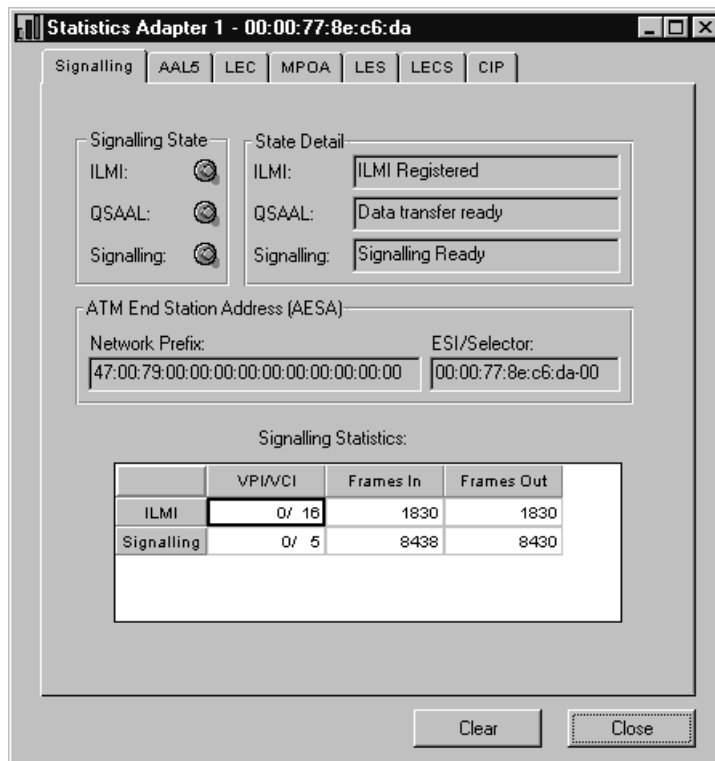

Figure 8-17. signaling Statistics

Check the following signaling indicators:

- All three signaling State LEDs should be green to indicate that ILMI, QSAAL, and signaling are active.
- The State Detail values should be similar to:
 ILMI: **ILMI Registered**
 QSAAL: **Data transfer ready**
 signaling: **signaling ready**

- In the signaling Statistics table, the Frames In and Frames Out columns should indicate traffic.

If any of the LEDs are red and statistics indicate a lack of traffic, make sure that the UNI Revision and other settings on the signaling Setup dialog box correspond to the settings of your switch.



NOTE

If PVC-only connections are used for all clients, it is normal for signaling states to be inactive.

The following is detailed signaling statistics information:

Field/Field Group	Description
signaling State LEDs	<p>State of the following signaling items:</p> <ul style="list-style-type: none"> • ILMI— Integrated Local Management Interface, which queries the ATM switch at startup and synchronizes to the switch's UNI signaling revision. • QSAAL—signaling ATM Adaptation Layer, which provides reliable transport of ATM switch and host messages over the ATM layer. • signaling <p>LED colors indicate the following:</p> <ul style="list-style-type: none"> – Green: enabled, active – Red: enabled, inactive – Yellow: trying
State Detail	Brief explanation of the ILMI, QSAAL, and signaling state as indicated by the corresponding LEDs.
ATM End Station Address	Network Prefix and ESI Selector Value parts of the end station's ATM Address.
signaling Statistics table	<p>Information for each signaling item:</p> <ul style="list-style-type: none"> • Virtual Path Identifier and Virtual Circuit Identifier used • Number of frames received • Number of frames sent

AAL5 Statistics

To display statistics about activity on an adapter's AAL5 layer, on the main CellView dialog box, highlight the adapter and click **Stats**. Then select the **AAL5** tab.

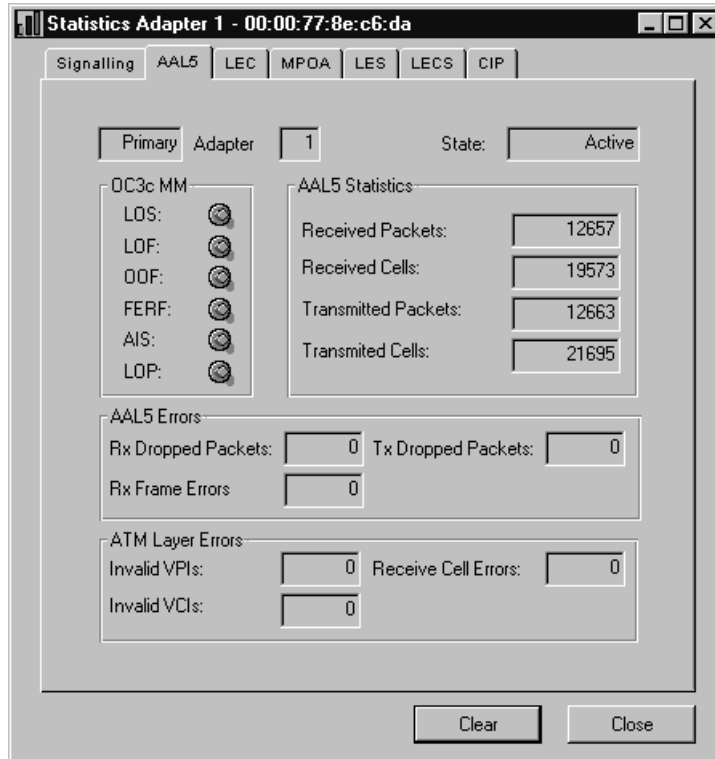

Figure 8-18. AAL5 Statistics

Check the following AAL5 indicators:

- All six OC3 MM LEDs should be green.
- The AAL5 Statistics fields should indicate traffic.

If any LEDs are red and statistics indicate a lack of traffic, a failure occurred somewhere in the cable or connectors.

Following is detailed AAL5 statistics information:

Field/Field Group	Description
Adapter	Adapter type (primary or backup) and adapter number.
State	Adapter state (active, down, inactive, or available).

Field/Field Group	Description
OC3c MM LEDs	<p>Status of error conditions used to monitor transmissions over the OC-3 optical fiber. In each case, green indicates that the error has not occurred, and red indicates that the error has occurred.</p> <ul style="list-style-type: none"> • LOS—Loss of Signal. Indication that the receiving equipment has lost the received signal. Used to monitor the performance of the PHY layer. • LOF—Loss of Frame. Indication that the receiving equipment has lost frame delineation. Used to monitor the performance of the PHY layer. • OOF—Out of Frame. Like LOF, indication that the receiving equipment has lost frame delineation. Used to monitor the performance of the PHY layer. • FERF—Far End Receive Failure. Indication of disconnection of the transmit path, though the receive path may be functional. • AIS—Alarm Indication Signal. Indication to the receiving equipment that a transmission interruption occurred either at the equipment originating the AIS signal, or upstream of the originating equipment. Transmitted instead of the normal signal to maintain transmission continuity. • LOP—Loss of Pointer. Indication that the receiving equipment has lost the pointer to the start of cell in the payload. Used to monitor the performance of the PHY layer.
AAL5 Statistics	Number of packets received, cells received, packets transmitted, and cells transmitted across the AAL5 layer.
AAL5 Errors	Number of errors in the AAL5 layer. Number of packets dropped and frame errors detected on receive and number of packets dropped on transmit.
ATM Layer Errors	Number of errors in the ATM layer. Number of invalid VIPs, invalid VCIs, and receive cell errors detected.

LEC Statistics

To display statistics for a LEC enabled on an adapter:

1. On the main CellView dialog box, highlight the adapter and click **Stats**. Then select the **LEC** tab.
2. If multiple LECs are on the adapter, select the LEC number to display the appropriate LEC dialog box.

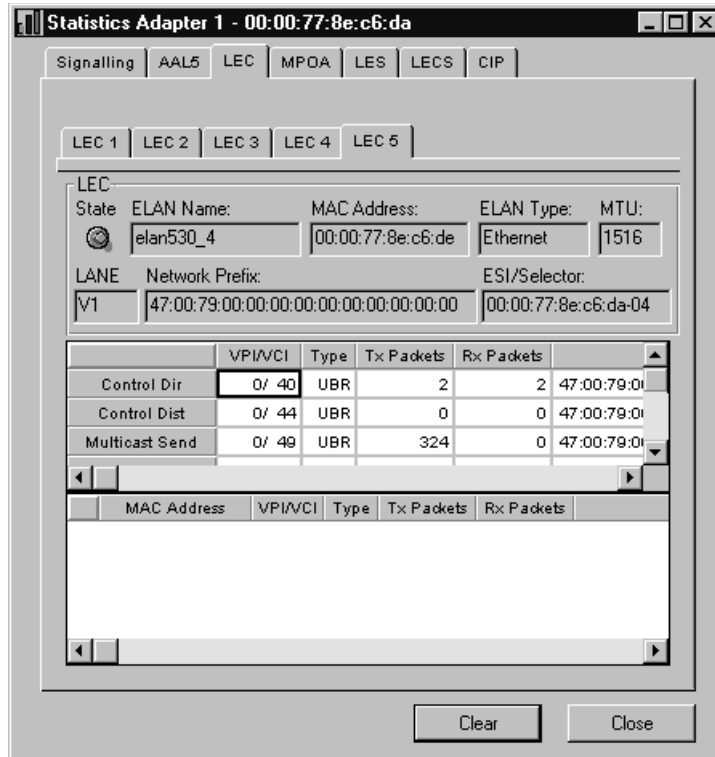

Figure 8-19. LEC Statistics

Check the following LEC indicators:

- The State LED should be green to indicate that the LEC is active.
- The Tx Packets and Rx Packets fields of the statistics tables should indicate traffic.

If the LED is red and statistics indicate a lack of traffic, make sure that the settings on the LEC setup dialog box correspond to your switch and ELAN. Also make sure that LES and/or LECS parameters are correct on the LEC setup dialog box.

Following is detailed LEC statistics information:

Field/Field Group	Description
LEC	LEC information: <ul style="list-style-type: none"> • LEC state LED <ul style="list-style-type: none"> – Green: enabled, active – Red: enabled, inactive – Yellow: trying • Name of the ELAN the LEC is assigned to • LEC MAC address • Type of ELAN the LEC is assigned to • MTU size of the LEC • LANE version of the LEC • ATM Network Prefix and ESI/Selector address of the LES or LECS the LEC connects to during the boot process
1st Statistics table	VPI/VCI number, bit rate type, number of transmitted packets, number of received packets, and MAC Address for each of the following channels: <ul style="list-style-type: none"> • Control Dir—Control Direct VCC, bi-directional point-to-point VCC between the LEC and the LES for sending control traffic. • Control Dist—Control Distribute VCC, unidirectional point-to-point or point-to-multipoint control VCC between the LES and the LEC for distributing control traffic. • Multicast Send—Bi-directional point-to-point VCC between the LEC and the BUS used to transmit multicast data to the BUS and for sending initial unicast data. • Multicast Forward—Point-to-multipoint VCC or unidirectional point-to-point VCC between the BUS and LEC used to distribute data from the BUS to the LEC. Must be established for a LEC to participate in the ELAN.
2nd Statistics table	Information about each LEC connection: <ul style="list-style-type: none"> • Connection number • MAC Address and VPI/VCI number of the target client • Connection bit rate type • Number of transmitted packets • Number of received packets • Network Prefix and ESI/Selector values of the target client's ATM address

MPOA Statistics

MPOA (Multi-Protocol Over ATM) is an ATM Forum standard that provides routing of legacy internetwork layer protocols (such as IP, IPX, AppleTalk) over ATM networks. MPOA requires a LANE implementation that complies with the *LAN Emulation Over ATM Version 2* specification.

MPOA separates routing processing from forwarding. It integrates LANE with Next Hop Resolution Protocol (NHRP). NHRP provides an extended address resolution protocol that enables inter-subnet communication without requiring routers in the data path. Where communicating LAN devices are behind LANE edge devices, MPOA allows the edge devices to perform internetwork layer forwarding and establish direct communications without being full function routers.

An MPOA system consists of inter-communicating MPOA Clients (MPCs) and MPOA Servers (MPSs). MPCs connect directly to each other across an MPOA system to forward internetwork layer packets over shortcuts, bypassing the packets' default routed LANE path. MPSs are logical components of routers that provide internetwork forwarding information to MPCs, enabling the shortcut connections. An MPOA-enabled LEC on the adapter communicates with one MPC (which can serve multiple LECs) to perform high-speed internetwork packet forwarding.

MPCs and the MPSs that serve them have an ingress role at the point where internetwork layer packets enter the MPOA system and an egress role at the MPOA system exit point.

In the ingress role, an MPC detects data packets entering the MPOA system and issues resolution requests to a corresponding ingress MPS for a shortcut address. The ingress MPS communicates with an egress MPS (based on the packet destination address), which finds the appropriate egress MPC to receive and send on the packets. The ingress MPS receives the shortcut address information from the egress MPS and sends the information in a resolution response to the ingress MPC. The MPC caches the information in its ingress cache, sets up a shortcut VCC, and forwards frames over the shortcut to the egress MPC.

In the egress role, an MPC receives internetwork data frames from other MPCs to be forwarded to its local interfaces/users. For frames received over a shortcut, the MPC adds appropriate DLL encapsulation and forwards them to the higher layers. The DLL encapsulation information is provided by an egress MPS in an MPOA Cache Imposition Request (resulting from its communication with the ingress MPS), and stored in an entry in the MPC's egress cache.

For detailed information, see the ATM Forum's *Multi-Protocol Over ATM* specification. (The ATM Forum's Web address is <http://www.atmforum.com>.)

To display MPOA statistics for an LEC on the adapter:

1. On the main CellView dialog box, highlight the adapter and click **Stats**. Then select the **MPOA** tab.
2. If multiple LECs are on the adapter, select the LEC number to display the appropriate MPOA LEC dialog box.

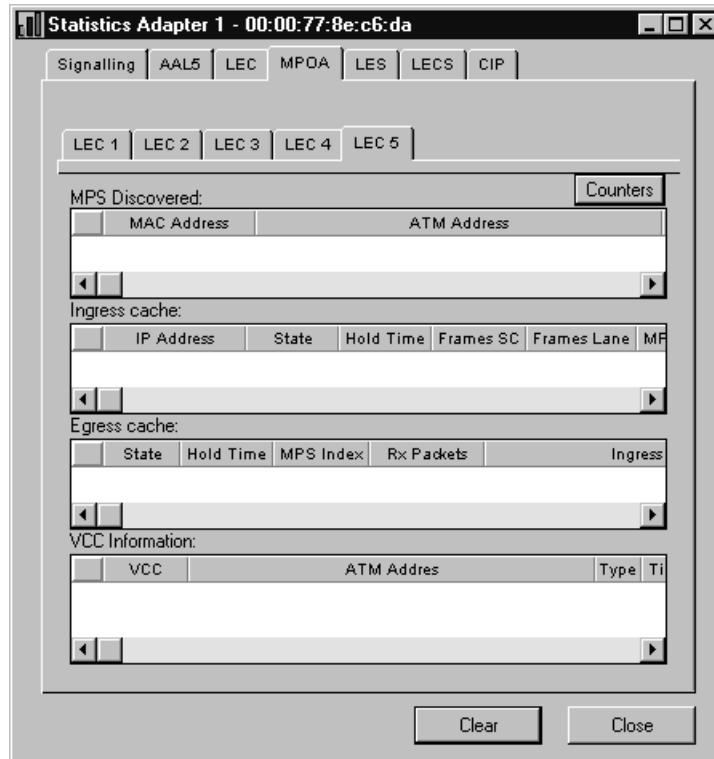

Figure 8-20. MPOA Statistics

You can view general information about MPOA statistics for a LEC as described in the next topic, [General MPOA Statistics](#). You can also view information about specific errors, requests, and transmissions, as described in [MPOA Counters](#) on page 93.

General MPOA Statistics

Following is detailed MPOA statistics information:

Field/Field Group	Description
MPS Discovered table	<p>Information about MPSs discovered on the network by the MPC associated with the LEC.</p> <ul style="list-style-type: none"> • MAC address of the MPS • ATM Address of the MPS • Keep Alive messages received from the MPS to notify the MPC that the MPS is alive and able to supply and maintain ingress or egress cache entries

Field/Field Group	Description
Ingress Cache	<p>Information about the ingress cache entries for the MPC associated with the LEC.</p> <ul style="list-style-type: none"> • Destination IP address of the packets in the data flow • State of the ingress cache entry • Hold Time during which the entry is allowed to remain in the cache before being deleted • Frames SC—Number of frames forwarded over a shortcut to an egress MPC • Frames Lane—If a shortcut is not used, number of LANE data frames forwarded to the destination. • Index number of the ingress MPS handling the MPOA Resolution Request for shortcut • Egress MPC at the other end of the shortcut receiving packets from this MPC to forward to its local interfaces/users. • ATM address of the Egress MPC at the other end of a shortcut (used as the Called Party Address while setting up a shortcut VCC)
Egress Cache	<p>Information about egress cache entries for the MPC associated with the LEC.</p> <ul style="list-style-type: none"> • State of the egress cache entry (resolved, purge, invalid). Packets received over shortcuts are forwarded only when the entry is in resolved state. • Hold Time during which the entry is considered valid in the cache before being deleted. • Index of the egress MPS sending the MPOA Cache Imposition Request to the egress MPC • Number of packets received from the ingress MPC to be forwarded to the local interface • ATM address of the ingress MPC that issued the MPOA Resolution request that resulted in imposition of this cache entry (Calling Party Address of an incoming shortcut VCC Setup Request) • Cache ID used as a key in combination with the requesting ingress ATM address to identify the egress cache entry • DLL Header attached to the internetwork layer packet being forwarded

Field/Field Group	Description
VCC Information	<p>Information about the VCCs used by the MPC associated with the LEC:</p> <ul style="list-style-type: none"> • VCC used to send internetwork layer packets from the ingress MPC to the egress MPC • Destination ATM Address to which the VCC connects • Code that indicates the packet type of the traffic carried on the VCC • Time after which the VCC will idle out due to inactivity • Number of packets transmitted on the VCC • Number of packets received on the VCC

MPOA Counters

To display details about statistics recorded by MPOA counters for an adapter and its MPOA-enabled LECs:

1. On the main CellView dialog box, highlight the adapter and click **Stats**. Then select the **MPOA** tab.
2. If multiple LECs are on the adapter, select the LEC number to display the appropriate MPOA LEC dialog box.
3. Click the **Counters** button above the MPS Discovered table.

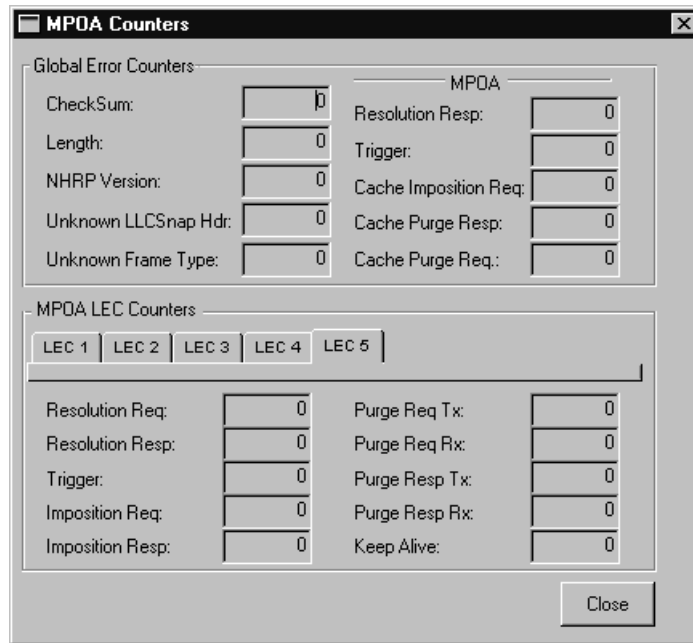

Figure 8-21. MPOA Counter Statistics

The following is detailed MPOA Counter statistics information:

Field/Field Group	Description
Global Error Counters	<p>Number of the following types of packet errors for all MPCs communicating with LECs on the adapter:</p> <ul style="list-style-type: none"> • CheckSum failure • Length validity • Next Hop Resolution Protocol Version compatibility • Unknown LLCSnap (Logical Link Control/SubNetwork Attachment Point) Header • Unknown Frame Type
MPOA	<p>Number of the following types of MPOA-specific errors for all MPCs communicating with LECs on the adapter:</p> <ul style="list-style-type: none"> • Resolution Response • Trigger (sent when an MPS determines the need for an inbound data flow shortcut, to trigger an ingress MPC into initiating an MPOA Resolution Request). • Cache Imposition Request • Cache Purge Response • Cache Purge Request

Field/Field Group	Description
MPOA LEC Counters	<p>Number of the following types of messages received/sent by the MPC communicating with the selected LEC:</p> <ul style="list-style-type: none"> • MPOA Resolution Requests transmitted by the MPC (in ingress role) to MPSs • MPOA Resolution Responses received from ingress MPSs • MPOA Triggers received from ingress MPSs • MPOA Cache Imposition Requests received by the MPC (in egress role) from MPSs • MPOA Cache Imposition Responses sent by the MPC to egress MPSs • Purge Requests transmitted to MPSs • Purge Requests received from MPSs • Purge Responses transmitted to MPSs • Purge Responses received from MPSs • Keep Alive messages received from MPSs

LES Statistics

To display statistics for an LES enabled on an adapter:

1. To make the LES tab available, click **Global** on the main CellView dialog box. Then on the Application dialog box, check the **Enable Advanced Settings** field and click **OK**.
2. On the main CellView dialog box, highlight the adapter and click **Stats**. Then select the **LES** tab.
3. If multiple LESs are on the adapter, select the LES number to display the appropriate LES dialog box.

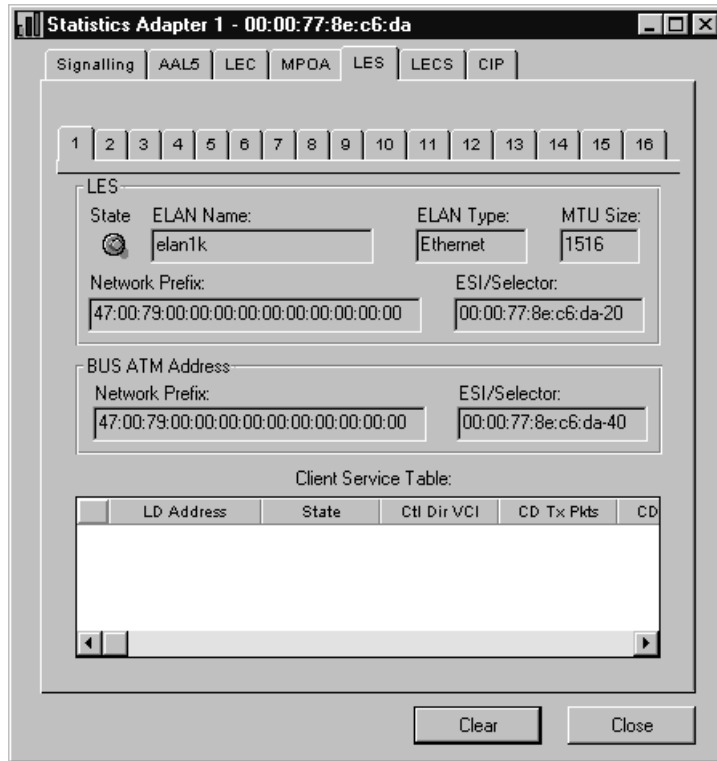

Figure 8-22. LES Statistics

Check the following indicators:

- The State LED should be green to indicate that the LES is active.
- The Tx and Rx fields of the Client Service Table should indicate traffic.

If the LED is red and statistics indicate a lack of traffic, make sure that the settings on the setup dialog box for the LES correspond to your switch and ELAN.

The following is detailed LES statistics information:

Field/Field Group	Description
LES	LES information: <ul style="list-style-type: none"> • LES state LED <ul style="list-style-type: none"> – Green indicates that the LES is enabled and active. – Red indicates that the LES is enabled but not active. – Grey indicates that the LES is disabled. • Name of the ELAN served by the LES • Type of ELAN served by the LES • MTU size of the ELAN served by the LES • ATM Network Prefix and ESI/Selector address of the LES

Field/Field Group	Description
BUS ATM Address	ATM Network Prefix and ESI/Selector address of the BUS on which the LES's host adapter is installed.
Client Service Table	Information about each connection between the LES and a LEC: <ul style="list-style-type: none"> • LAN Destination (LD) address represented by the LEC • Connection state • Virtual Circuit Identifier of the Control Direct (CD) VCC used to exchange control information with the LEC • Number of Control Direct packets transmitted to the LEC • Number of Control Direct packets received from the LEC

LECS Statistics

To display statistics for an LECS enabled on the adapter:

1. To make the LECS tab available, click **Global** on the main CellView dialog box. Then on the Application dialog box, check the **Enable Advanced Settings** field and click **OK**.
2. On the main CellView dialog box, highlight the adapter and click **Stats**. Then select the **LECS** tab.

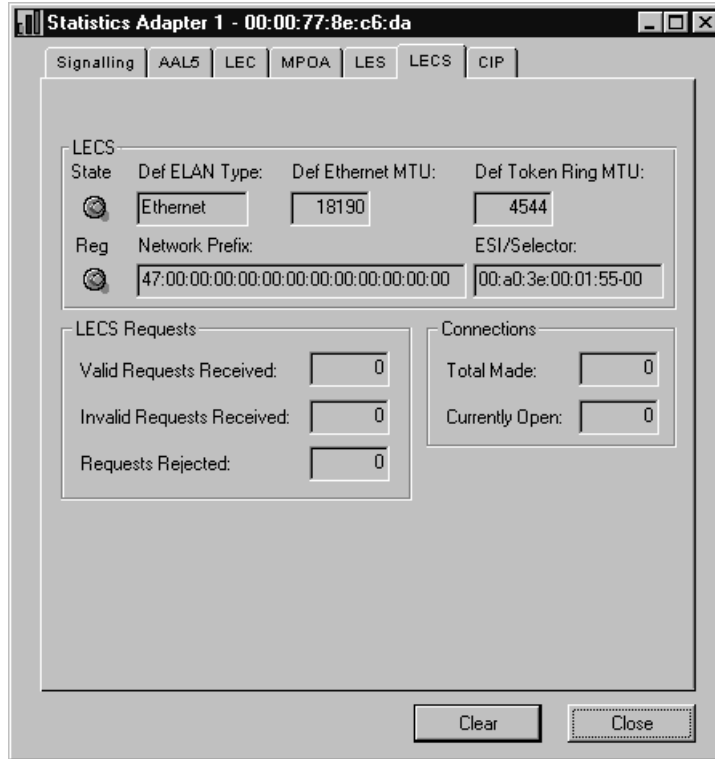

Figure 8-23. LECS Statistics

Check the following indicators:

- The State and Reg LEDs should be green to indicate that the LECS is active and its ATM address is registered.
- The LECS Requests and Connections fields should indicate that the LECS is processing requests and making connections.

If one of the LEDs is red and statistics indicate a lack of activity, make sure that the settings on the LECS setup dialog box correspond to your switch and ELAN.

The following is detailed LECS statistics information:

Field/Field Group	Description
LECS	LECS information: <ul style="list-style-type: none"> • LECS state LED <ul style="list-style-type: none"> – Green indicates the LECS is enabled and active. – Red indicates the LES is enabled but not active. – Grey indicates that the LES is disabled. • Default ELAN type the LECS assigns to clients • Default MTU size the LECS assigns to Ethernet clients • Default MTU size the LECS assigns to Token Ring clients • Registration LED, which indicates whether the LECS is registered with the switch to use the Well Known ATM address • ATM Network Prefix and ESI/Selector address of the LECS
LECS Requests	Number of valid and invalid connection requests the LECS receives from clients. Also, number of LEC requests rejected by the LECS.
Connections	Total number of connections made between the LECS and LECs. Also, number of LEC connections that have been requested but not completed.

CIP Statistics

To display statistics for an enabled CIP client, on the main CellView dialog box, highlight the adapter and click **Stats**. Then select the **CIP** tab.

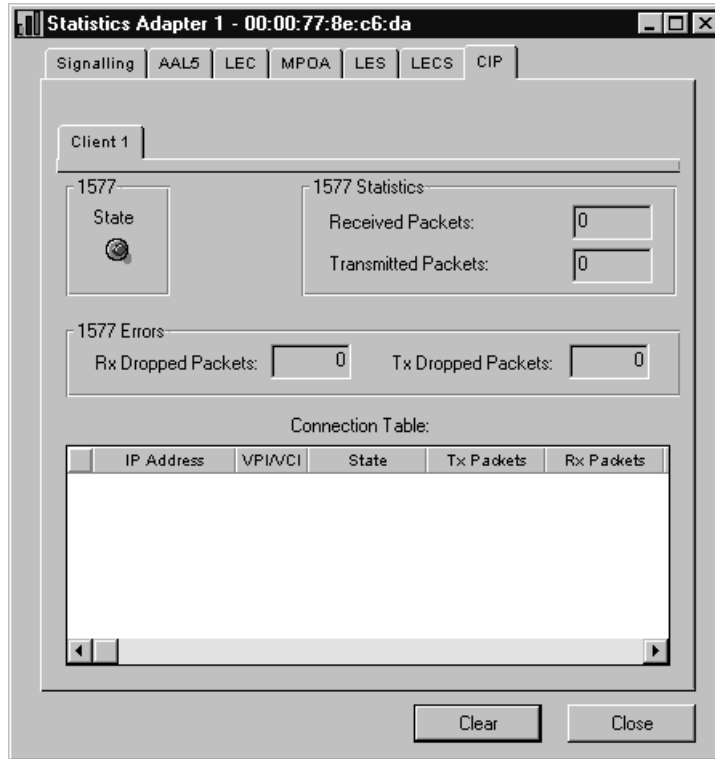

Figure 8-24. CIP Statistics

Check the following indicators:

- The 1577 State LED should be green to indicate the that CIP client is active.
- The 1577 Statistics fields should indicate traffic.

If the LED is red and statistics indicate a lack of traffic, make sure the settings on the CIP setup dialog box correspond to your switch settings.

The following is detailed CIP statistics information:

Indicators	Description
1577 State	Activity state of the CIP client.
1577 Statistics	Number of packets received and transmitted by the CIP client.
1577 Errors	Number of packets dropped by the CIP client during receive activity and transmission activity.

Indicators	Description
Connection Table	Information about CIP client connections: <ul style="list-style-type: none">• IP Address of the target client• VPI and VCI of the connection• State of the connection• Number of packets transmitted on the connection• Number of packets received on the connection• Network Prefix and ESI/Selector values of the connected client's ATM address (or indication of a PVC connection)

Global Settings

Settings for global routines control CellView parameters that are common to all adapters. You are not required to restart end stations to make global settings take effect. Use Global settings to:

- Control application display settings (described in the next topic, [Controlling Application Display Settings](#))
- Display signaling connection settings in drivers (described in [Displaying signaling Connections Settings on page 103](#))
- Produce information to use for debugging (described in [Producing Debugging Messages on page 104](#))

Controlling Application Display Settings

Use the Application dialog box to control display settings for CellView Setup and Statistics routines, such as refresh rates and tabbed dialog boxes available for Setup and Statistics routines.

To control display settings:

1. From the main CellView dialog box, click **Global** to display the Application dialog box.

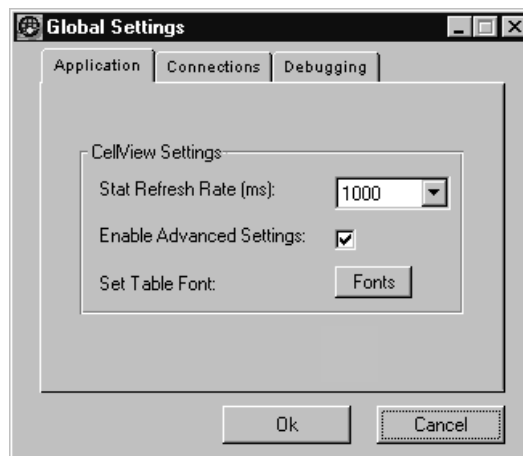

Figure 8-25. Global Application Settings

2. Specify global application settings as follows:

Use this field...	To do this...
Stat Refresh Rate	Control the update or refresh rate, in milliseconds, of the data fields in the Statistics dialog boxes.

Use this field...	To do this...
Enable Advanced Settings	Activate the tabs for the LECS and the LES in the Setup and Statistics dialog boxes. This setting does not affect the enable/disable condition of the ELAN servers. The tabs can be hidden from view while the servers remain enabled.
Set Table Font	Select the font used for tables in dialog boxes.

Displaying signaling Connections Settings

Use the Connections dialog box to display the signaling connections configuration in adapter drivers. Currently, these settings cannot be changed; they are preset in the drivers.

To display the Connections dialog box, click **Global** on the main CellView dialog box and select the **Connections** tab:

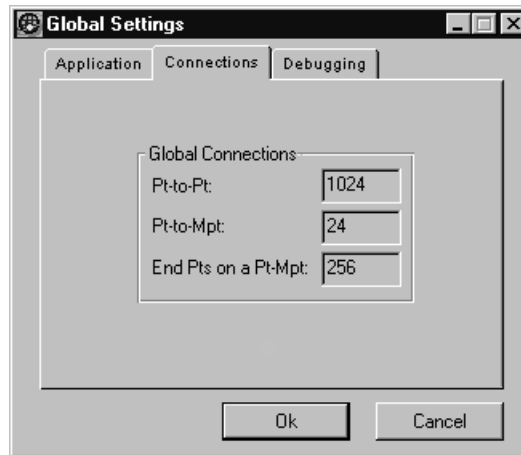

Figure 8-26. Global Connection Settings

The following table describes Connections fields:

Use this field...	To do this...
Pt-to-Pt	View the maximum number of SVC connections with other end stations that are allowed simultaneously.
Pt-to-Mpt	View the maximum number of SVC multipoint connections that are allowed simultaneously. These are used primarily between LECs and an LES/BUS.
End Pts on a Pt-Mpt	View the maximum number of end points on each multipoint connection. This affects the number of clients allowed on the same ELAN.

Producing Debugging Messages

Use the Debugging dialog box as a troubleshooting aid for the adapter. If you have difficulty establishing connections with other network nodes or establishing ILMI connectivity with the switch, enable the appropriate debug options. The debug options produce signaling debug messages from various modules to help isolate the problem.

Debug logs are appended to the Event Log. Be sure to disable debugging options when debugging is complete.



CAUTION

Caution must be used when leaving this function enabled for lengthy periods, as it may require considerable drive space.

To produce Debugging messages:

1. From the main CellView dialog box, click **Global** and select the **Debugging** tab.



Figure 8-27. Global Debugging Settings

2. Select debugging options, as follows:

Use this field...	To do this...
API	Track the signaling Application Program Interface (API). These are the routines used by the application software to manage SVCs.
signaling	Track the signaling PDUs exchanged by the host signaling and the switch.
ILMI	Track the IME PDUs exchanged by the host signaling and the switch. Useful in debugging ILMI Address Registration problems.

Overview

This chapter explains how to install your adapter's driver on file servers running Novell NetWare version 4.x, 5.0, or 5.1. It provides information about the following:

- Tasks that should be done before you start the installation, described in the next topic, *Before You Start*
- Considerations for setting up redundant link support, described in *Providing Redundant Link Support on page 108*
- Novell support pack installation, described in *Installing the Novell Support Pack on page 108*
- Driver installation, described in *Installing the NetWare Integrated (Fat) Driver on page 109* and *Installing the NetWare ODI (Thin) Driver on page 118*
- Adding clients after the driver installation, described in *Adding Clients after Driver Installation on page 117*
- Driver removal, described in *Removing a Driver on page 117*

Before You Start

Before you install the driver, it is recommended that you:

- Read any *Read Me First* documentation in your installation kit.
- Make sure the computer meets the minimum requirements listed in *Minimum System Requirements on page 3*.
- Install the adapter card in the computer.
- Read through the entire sequence of installation steps.
- Back up the system.

Also be sure to do the following:

- Make sure your ATM switch supports the UNI 3.0, 3.1, or 4.0 signaling standard for SVCs.

Check your switch documentation for correct settings. By default, the adapter is automatically configured to the switch's UNI version.

- If TCP/IP is not installed on the server and one or more clients are to use this protocol, install TCP/IP on the server before installing the ATM driver. (TCP/IP is required for CIP clients.)
- Determine the assigned IP address and subnet mask address for the adapter.
- If the adapter is to be enabled as an SNMP agent, the `TRAPMIB.NLM`, `SONETMIB.NLM`, `LECMIB.NLM`, and `ATOMMIB.NLM` files are required with the driver.

These should be installed with the driver using the INSTALL utility. If you use a different installation utility, you may need to copy these files from the Interphase installation CD (at: <CD drivename>:\drivers\6575\netware\id2.0), or from the directory containing the downloaded installation file, into `sys:\system` volume.

- If a backup ATM adapter is being installed, review the guidelines in [Providing Redundant Link Support on page 108](#).
- If the latest Novell NetWare Support Pack for your operating system is not installed on the system, install the support pack, as described in [Installing the Novell Support Pack on page 108](#).

Providing Redundant Link Support

Backup adapters (also called *secondary* or *redundant* adapters) provide end stations with redundant link support. A backup adapter takes on all the functions of an assigned primary adapter when the primary adapter experiences a physical line failure, or when a user deactivates the primary adapter. All the primary adapter's clients and IP addresses are moved onto the backup adapter until the primary adapter resumes operation or is manually reactivated.

At least two Interphase ATM adapters must be in an end station to configure redundant link support. There must be at least one primary adapter for each backup adapter.

A backup adapter can support one to three primary adapters. For example, an end station can contain two primary adapters and two backup adapters, with each primary adapter assigned to a backup. Or it can contain up to three primary adapters, all assigned to one shared backup adapter.

The board type of the backup adapter must be the same as the board type of its primary adapter(s). That is:

- A 155 Mbps adapter can back up only 155 Mbps adapters.
- 155 Mbps with 4 K VC adapter can back up only 155 Mbps with 4 K VC adapters.

You can designate backup adapters during driver installation by identifying the backup adapter slot number for each client on a primary adapter. After installing the driver for all primary adapters, you can install the driver for the backup adapter.

Available adapter numbers are determined by the number of adapters installed. Adapter 1 is always a primary adapter. We recommend that the highest available adapter number(s) be assigned to the backup adapter(s). For example, if your end station contains two primary and one backup adapters, designate adapters 1 and 2 as primary adapters, and adapter 3 as the backup adapter.

Installing the Novell Support Pack

Install the NetWare support pack for your system as follows:

1. Go to the Novell support web site at <http://support.novell.com>. Click on the **PATCHES AND FILES** option on the SUPPORT LINKS list, then click on the **Minimum Patch List** option in the RELATED LINKS list.
2. Select and download the latest support pack for your system.

NetWare OS	File Name	File to Install
5.1 (See NOTE if you are running a multi-processor system)	Netware 5.1 Support Pack 1 (128 bit)	NW51SP1.EXE (or .exe associated with the service pack)
	Netware 5.1 Support Pack 1 (56 bit)	E51SP1.EXE (or .exe associated with the service pack)
5.0	Netware 5.0 Support Pack 5 (or latest service pack)	NW5SP5.EXE (or .exe associated with the service pack)
4.x	NetWare 4.11/4.2 Support Pack 9 (or latest service pack)	NW4SP9.EXE (or .exe associated with the service pack)

Note: Ensure that you have NWPA.NLM 3.06 on your system. Go to <http://support.novell.com/cgi-bin/search/tidfinder.cgi?10054376> for additional information.

3. Install the appropriate file(s) on your server. Follow the instructions displayed on the Novell Technical Information Document page.
4. Reboot the server.

To install the NetWare Integrated driver go to [Installing the NetWare Integrated \(Fat\) Driver](#) below. To install the NetWare ODI driver go to [Installing the NetWare ODI \(Thin\) Driver on page 118](#).

Installing the NetWare Integrated (Fat) Driver

For NetWare, the driver supports up to four adapters per machine. It allows each adapter to join up to 16 different ELANs (Ethernet or Token Ring) and one Classical IP-over-ATM (CIP) segment simultaneously. During installation, you can initialize up to 16 LECs, or 15 LECs and 1 CIP client (also shown as 1577 client), per adapter. Client 1 is enabled by default. All remaining clients and LAN services are disabled. (For details about driver features, see [Software Drivers on page 1](#).)

If an earlier version of an Interphase ATM adapter driver is installed on the server, remove it before installing the new driver. For instructions, see [Removing a Driver on page 117](#).

Starting the Installation

To get started:

- If you are installing from the zipped installation file `sx00219-d00.exe` available at the Interphase web site:
 - If needed, download the file as instructed in [Documentation Updates on page viii](#).
 - Create a temporary installation directory (for example `C:\NWSERVER\ATM`).
 - Extract the files in the downloaded zipped file to the temporary installation directory.
- If you are installing from an Interphase CD-ROM, insert the CD-ROM, and mount it as follows:
 - For OS 5.0 or 5.1, type `load cdrom`
 - For OS 4.x, type:

```
load cdrom
cd mount all
```

Then do the following:

1. At the server prompt, enter the following command:

```
load nwconfig (OS 5.x)
```

Or

```
load install (for OS 4.x)
```
2. When the Installation Options menu appears, select **Driver Options (load/unload disk and network drivers)** and then select **Configure network drivers**.
3. In the Additional Driver Actions dialog box, select **Select an additional driver**.
4. In the Select A Driver dialog box:
 - If this is the first installation of the driver, it will not appear in the selection list. Press the **Insert** key and continue to step 5.
 - If you are repeating the driver installation to initialize an additional client, skip to step 7.
5. When prompted, specify the path of the software driver. (The path should be the NetWare directory on the CD-ROM. If installing from a zipped downloaded file, it should be the directory containing the extracted files.)
6. Press **Enter**.

The following dialog box appears, listing the driver files.

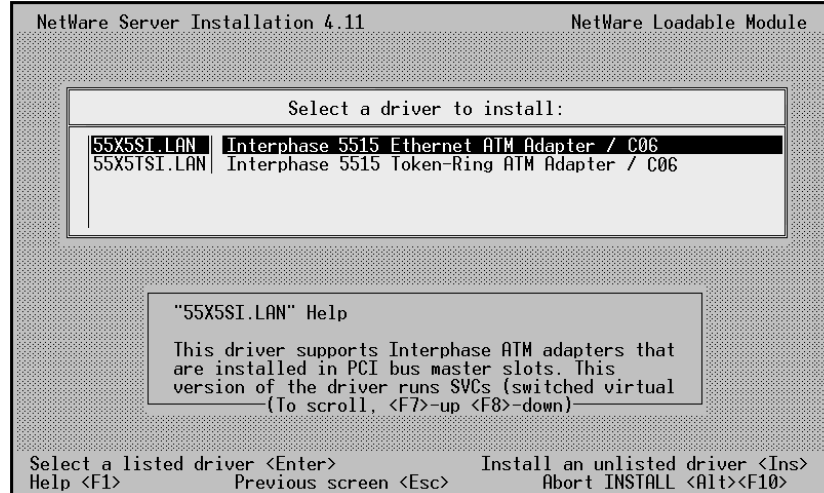

Figure 9-1. Selecting a Driver

7. Select the driver that matches the adapter speed and the network framing type.
 - 55x5 indicates PCI compatible, and a speed of 155 Mbps. This part of the driver name applies to PCI (55x5), CompactPCI (65x5), and PMC (45x5) adapters.
 - The letters *SI* indicate an Ethernet ELAN type; the letters *TSI* indicate a Token Ring ELAN type.

Driver	Adapter Speed	Frame Type
55x5si.LAN	155 Mbps (5515, 5575, 6575, 4515, 4575)	Ethernet
55x5TSI.LAN	155 Mbps (5515, 5575, 6575, 4515, 4575)	Token Ring



CAUTION

Ethernet and Token Ring drivers cannot be mixed on the same machine. You must use the same frame type for all channels on all adapters installed in the NetWare server.

8. Confirm the name of the driver and select **Yes**.
 - The driver files are copied to the NetWare server.

Continue the installation with the procedures in the next section, [Configuring Protocols and Parameters](#).

Configuring Protocols and Parameters

After you select the driver to install, the following dialog box appears, enabling you to configure network protocols and parameters for each client on the adapter:

```

NetWare Server Installation 4.11                               NetWare Loadable Module

--- 5515SI_1 Protocols ---
--- IPX (always selected)
[ ] TCP/IP
[ ] AppleTalk

--- 5515SI_1 Parameters ---
Channel:                1
ELAN Name:              Elan1
Slot Number:            2
Backup Slot:            0

Board 5515SI_1 (Driver 5515SI) Actions
Select/Modify driver parameters and protocols
Save parameters and load driver

Help <F1>  Previous screen <Esc>  Change Lists <Tab>  Abort <Alt><F10>

```

Figure 9-2. Protocols/Parameters Configuration

The driver name in the box titles indicates the increment of the client being configured. For example, if you are initializing the second client on an adapter with the Ethernet driver, the name reads 55x5si_2 (_2 for Client 2).

1. To configure the appropriate network protocol for the client:
 - a. Select **Select/Modify driver parameters & protocols** at the bottom of the dialog box.
 - b. When the highlight moves to the TCP/IP field, select the protocol to enable (TCP/IP or AppleTalk).



NOTE

TCP/IP is required for a CIP (or 1577) client.

- c. If you select TCP/IP (required for a CIP client), enter the IP Address and IP Mask for the client in the TCP/IP dialog box. Then press **F10** to save the change and exit the dialog box.
2. If you need to change the an Ethernet driver frame type from the default of 802.2, press **F3** select a frame type from the Frame Type List. Then press **F10** to save the change and exit the dialog box.

**NOTE**

An Ethernet II frame type is required for a CIP client.

3. In the Parameters section of the dialog box, the Channel number value defaults to 1. In the Channel field, press **Enter** to edit the value. Then select the client number in the pop-up dialog box.
Configure **ELAN clients** use to Channels 1 through 15, and **CIP (1577)** clients to use Channel 16.

**CAUTION**

Never use the same channel number another client has used.

4. If the client being initialized is an LEC, and if the LEC is to be assigned to a specific ELAN, highlight the **ELAN Name** value and enter the ELAN name.

**NOTE**

For initialization purposes, Channel 1 must be assigned to the ELAN that uses the largest MTU size.

5. If multiple adapters are installed, the slot number is required for each client on each adapter. In the **Slot Number** value, enter the slot number of the host adapter.
6. If the end station contains an adapter to back up the host adapter, highlight the **Backup Slot** value, and enter the slot number of the backup adapter. (See [Providing Redundant Link Support on page 108](#) for information about backup adapters.)



NOTES

Adapter 1 must be a primary adapter.

For a backup adapter, do not enter a backup slot number.

You must identify the host adapter's slot number before you can enter a backup slot.

If only one adapter is installed, you cannot enter a backup slot.

7. Each LEC is assigned to an LES that manages client connections with other LECs. By default, each client will connect to an LES through an LECS, which is assigned the well-known ATM address.
 - If the LEC is to connect to an LES via an LECS with a different ATM address, enter the LECS's full ATM address in the **LECS Network Prefix** and **LECS ESI/Sel** fields.
(The default of 0 in the **LECS Network Prefix** field specifies the well-known address.)
 - If LEC is to bypass the LECS and connect directly to an LES, enter the LES's full ATM address in the **LES Network Prefix** and **LES ESI/Sel** fields.
(The default of 0 in the **LES Network Prefix** field specifies that the LECS is *not* bypassed.)
-



NOTE

If an ATM address is entered in the LES Network Prefix and LES ESI/Sel fields, the LECS Network Prefix and LECS ESI/Sel fields are ignored.

8. If the client being configured is a CIP client, in the **1577 Enable** field, enter **Y**.
The prerequisites for a CIP client are:
 - TCP/IP is installed on the machine.
 - The target client is bound to the TCP/IP protocol.
 - The client must use the Ethernet II frame type (as shown in the `FRAME` parameter of the `LOAD` command).

Loading the Driver

When you finish configuring the protocols and parameters, do the following to finish loading the driver:

1. On the Protocols and Parameters screen, press **Esc** to move to the bottom box.

2. Select **Save parameters and load driver**.
3. A dialog box appears containing a random network number for binding the IPX protocol to the driver.

**CAUTION**

For a CIP client to operate correctly, do *not* bind it to the IPX protocol.

- If you are configuring a LANE client, press **Enter** to accept the binding number.
 - **If you are configuring a CIP client**, press the **ESC** key, and select **NO** at the prompt.
4. Next, a prompt appears for loading the driver for an additional channel. The maximum is 16 clients (Client 1 plus 15 additional clients).
At the prompt, do one of the following:
 - If you do not want to load the driver for an additional client, select **No**. Then skip to [Configuring the System for 4K or 9K MTU Support on page 116](#).
 - If you want to load the driver for another client, select **Yes**. Then continue to step 5.

**CAUTION**

Load the driver for a CIP (1577) client only once. Additional instances of the driver for CIP clients will not be bound to the IP protocol.

5. If you selected to load the driver for another client, the Select a Driver dialog box reappears (shown in [Figure 9-1 on page 111](#)). This time the driver is obtained from your hard disk instead of the CD-ROM. To continue:
 - a. Select the same driver you installed for the previous client. (Remember, Ethernet and Token Ring cannot be mixed on the same machine.)
 - b. Press **Enter** to confirm the driver name.
 - c. When the Protocols and Parameters dialog box reappears, repeat the configuration steps for the new client, as described in [Configuring Protocols and Parameters on page 112](#).

If you installed any Token Ring or CIP clients, or an Ethernet client that requires an MTU size greater than 1516, continue the installation with the procedures in the next section, [Configuring the System for 4K or 9K MTU Support](#). Otherwise, skip to [Completing the Driver Installation on page 117](#).

Configuring the System for 4K or 9K MTU Support

The ATM driver supports 4K MTU, 9K MTU, or 1577 (CIP) clients, and allows dynamic configuration of different MTU sizes.

To enable support for 4K or 9K MTU sizes, the Interphase versions of the `ETHERTSM.NLM` and `MSM.NLM` files must be loaded in `sys:\sys` volume on the server. These files are located in the NetWare directory on the Interphase CD-ROM or in the directory containing the downloaded installation file.

The NetWare system's maximum physical receive packet size must be configured to support the largest Maximum Transfer Unit (MTU) size used by clients on the system's ATM adapter(s). You will need to change the system's default physical receive packet size for the following client types:

- Token Ring
- CIP clients
- Ethernet clients with a 9K MTU size

To change the system's maximum physical receive packet size:

1. Press **Alt-Esc** to switch to the text window.
2. Type **load monitor**
3. In the console monitor window, tab to the Available Options window and select **Server Parameters**.
4. In the Select a parameter category window, select **Communications**.
5. In the Communications Parameters window, scroll to the **Maximum Physical Receive Packet Size** field.
6. Press **Enter** to edit the field, and type in the desired MTU size.
 - For 4K MTU (Token Ring), enter **5120**
 - For 9K MTU (CIP, 9K Ethernet), enter **10240**
7. Press **ALT-F10**, and select **Yes** at the prompt to save the change and exit the monitor utility.

Editing the Boot Configuration File

The parameters in the boot configuration file are used to configure system components during the boot process. On NetWare 5.x systems, boot configuration properties are contained in the `INETCFG.NCF` file. On NetWare 4.x systems, boot configuration properties are contained in the `AUTOEXEC.NCF` file.

On NetWare 4.x systems, you may need to edit `AUTOEXEC.NCF` to add the **LOAD asig** and **LOAD cvconf** commands. These commands should be included after the last client **LOAD** commands. The **LOAD asig** command automates the ATM startup, and the **LOAD cvconf** command loads the CellView configuration file.

Completing the Driver Installation

When you finish the initial driver setup for all clients, complete the driver installation as follows:

1. Exit the NetWare `nwconfig` (or `install`) utility.
2. Reboot the server.

Next, with the driver and adapter(s) installed, start CellView and configure the adapter(s) as described in [Using CellView for NetWare Servers on page 121](#).

If you need to verify that the driver is up and running, check CellView statistics, as described in [Statistics Information on page 145](#).

Adding Clients after Driver Installation

If you need to initialize additional LEC or CIP clients on an adapter after completing the driver installation for that adapter, repeat the driver installation steps as described in [Installing the NetWare Integrated \(Fat\) Driver on page 109](#). You can select the driver from a list of installed drivers rather than from the CD-ROM.

Removing a Driver

To remove the driver, do the following:

1. At the server prompt enter the following command:

```
load install
```

 (for OS 4.2)
Or

```
load nwconfig
```

 (for OS 5.0 or 5.1)
2. When the Installation Options menu appears, select **Drivers options (load/unload disk and network drivers)** and then select **Configure network drivers**.
(You might need to press **Alt-Esc** to toggle from the monitor screen to the Installation Options menu.)
3. Select **Unload a selected driver**.
4. Select the driver to remove.
5. Exit the NetWare `install` utility and reboot the server.



NOTE

Do not attempt to reinstall a driver before rebooting the NetWare server.

Installing the NetWare ODI (Thin) Driver

Installation

You must use the server version of ATMTSM.NLM. This must be installed on the server before installing the Interphase ATM driver software. Refer to the Novell ATM technical information and Frequently Asked Questions (FAQ) documents for details on installing the Novell ATM LAN Emulation Client software.

The Interphase ATM driver software should be installed and configured using INETCFG.NLM. Refer to the Novell ATM technical information and FAQ documents for details on installing and configuring ATM adapters. Information on INETCFG.NLM can be found in NetWare OS documentation: *Basic Protocol Configuration* and *Advanced Protocol Configuration and Management Guide*.

The Interphase ATM driver will automatically load PARSER.NLM and ATMTSM.NLM if not already loaded.

Configuration Options

The following are the Interphase ATM driver configuration options available with the INETCFG.NLM utility:

- **Board Name**
This option specifies a name to associate with the driver instance. This name must be unique and is required for the driver to load.
- **MTU Size:**
This option specifies the maximum transmission unit size. This is also referred to as the maximum frame size. It specifies the largest frame that can be transmitted on or received from the network. The recommended MTU size for emulating an Ethernet LAN is 1516. The recommended MTU size for emulating a Token Ring LAN is 4544. The default is 1516.
- **Slot:**
This option specifies the slot number that corresponds to the expansion slot where the ATM adapter is installed. Single adapter installations do not need to specify a slot number. Multiple adapter installations should specify the slot number for each adapter installed in the system. If slots are not specified, the next uninitialized adapter found will be selected and initialized.
- **Standby:**
This option specifies the slot number that corresponds to the expansion slot where the standby ATM adapter is installed. The adapter specified by the standby option will be inactive until the primary adapter fails. The primary adapter is selected by the slot option described above.
- **Reinstate:**
This option specifies whether the primary adapter is automatically reinstated as operational after a failover to the standby adapter occurs and the primary adapter

is again functioning. MANUAL reinstate will not automatically reinstate the primary adapter after a failover occurs. The default is AUTO reinstate.

- ESI:

End Station Identifier (MAC address) override. The value entered will override the ESI on the adapter. You may choose 'UNDEFINED' to use the original ESI stored on the adapter.

- Buffers:

This option specifies the maximum number of receive buffers available to the driver. Generally, the more buffers made available to the driver will result in less of a chance that receive packets will be dropped. The driver may limit this maximum number based on adapter memory constraints and MTU size. The default is 50.

- Framing:

This option specifies the framing mode of SONET or SDH. The default is SONET framing.

Troubleshooting Tips

The yellow light on the adapter should flash approximately once every second. If it does not flash, the driver is either not loaded or the host system is not functioning correctly.

The status of the adapter can be obtained by re-loading the driver with the additional load line parameter of STATUS. For example,

```
LOAD INPHATM.LAN STATUS
```

will display the status of all the adapter drivers previously loaded.

If incorrect SLOT= parameter values are specified, the driver will not load. It will, however, display the valid slot values where ATM adapters were found. This information can be used to correct the invalid slot parameter values.

Overview

This chapter provides information about how to use the CellView connectivity management utility to set up and monitor network clients and servers on Interphase ATM adapters. This chapter describes the text-based version of CellView for NetWare, which is compatible with Novell NetWare Server versions 3.12, 4.x, 5.0, and 5.1.

This chapter describes the following:

- CellView features, described in [CellView Features on page 121](#)
- Information to consider before you use CellView, described in [Before You Start on page 122](#)
- CellView startup procedure, described in [Starting CellView on page 124](#)
- Main CellView dialog box, described in [Main CellView Information on page 125](#)
- CellView keyboard commands, described in [CellView Keyboard Commands on page 126](#)
- Setup procedures, described in [Setting Up ATM Network Services on page 127](#)
- CellView statistics, described in [Statistics Information on page 145](#)



NOTE

For adapters that include one or more ATM PMC daughtercards, *adapter* refers to each daughtercard.

CellView Features

CellView enables you to:

- Configure primary and backup features on adapters
- Configure adapters to support either SONET or SDH framing standards and use a VPI other than 0
- Enable, disable, and configure up to 16 LAN Emulation Clients (LECs), or 15 LAN Emulation Configuration Server (LECs) and 1 Classical IP-over-ATM (CIP) client, per adapter
- Enable, disable, and configure up to eight LAN Emulation Servers (LEs) and one CIP ARP server per adapter
- Enable, disable, and configure one LECS per adapter
- Set up Permanent Virtual Circuit (PVC) communications with other end stations

- Specify that direct Virtual Circuit (VC) connections between end stations not be released if LANE services are lost
- Display operating statistics for:
 - SONET, signaling, and cell-level activity
 - ATM Adaptation Layer 5 (AAL5) activity
 - LEC membership and activity
 - MPOA activity
 - LES activity
 - LECS activity
 - CIP activity

All screens and dialog boxes are in text format and require keyboard input for navigation. Pressing the **F10** key sends changes to the driver for immediate, dynamic update.

Before You Start

At least one client must be enabled and fully configured to run network applications on the end station. The degree of configuration needed for adapters depends on whether network services are installed. For example, if the LECS, LESs, and ARP server are already running on the network, you only need to enable and configure local clients on the adapter.

Before beginning CellView configuration, verify the following:

- At least one adapter is installed in the end station.
- The appropriate adapter driver is installed.
- At least one LEC or CIP client is installed with the driver (and enabled at driver initialization).
- The machine was rebooted after driver installation.

If these tasks are not complete, complete them now. See the appropriate chapter(s) for instructions.

Also do the following:

- Gather ATM address information for the adapter, as described in the next topic, [ATM Address](#).
- If the system includes a backup adapter, read the information in [Redundant Link Support on page 123](#).
- If you are unfamiliar with how LEC-to-ELAN connections are managed by LES and LECS servers, read the information in [LES and LECS Functions on page 124](#).

ATM Address

During configuration, you will need to know the end station's unique 20-byte ATM address. The ATM address consists of the network prefix and the ESI/Selector values.

The **Network Prefix** is the 13-byte link address of the adapter, as set by the ATM switch.

The 7-byte **ESI/Selector** consists of a unique End Station Identifier (ESI) and a pointer (selector) with the following values:

- The ESI value is the 6-byte MAC address of the adapter (for example, *00:00:77:86:da:61*).
- The Selector value is a 1-byte pointer to clients and services located in the end station (for example, *00*).

The Selector value for the end station is always 00. The Selector values for clients and services located in the end station are as follows:

Item Number	Selector Value Range
LEC1–LEC16	0x00–0x0f
LES1–LES8	0x20–0x27
BUS1–BUS8	0x40–0x47

Redundant Link Support

Redundant link support provides systems with high network availability. During driver installation, if multiple adapters are installed, you can assign a backup adapter to one primary adapter or to multiple adapters of the same board type with similar configurations (such as the same chipset, control RAM, and reassembly RAM).

After primary and backup adapters are initialized and the system is running, the driver monitors the status of each data link. If the driver detects a link failure in a primary adapter, it effects a fail-over. That is, the driver finds the backup adapter designated for that link. If the backup is available, the driver assigns it the clients and services of the failed primary adapter, and activates the backup. The switch is transparent to end-users and upper networking layers such as TCP/IP, ensuring no significant downtime.

You can use CellView to monitor the link status of primary and backup adapters. You can designate whether the primary adapter automatically resumes operation after a link failure resolution. You can also change a backup assignment.

LES and LECS Functions

To communicate on an ATM network, an LEC must join an Emulated LAN (ELAN). The ELAN consists of a group of end stations that communicate among themselves with the same MTU size, the same frame format, and the same broadcast/multicast services.

The LES is the central server for an ELAN. The LES provides address registration, address resolution, and broadcast services for all ELAN members. The NetWare driver allows up to eight LESs to be enabled per adapter at one time (allowing support for up to eight ELANs).

The LECS serves LESs by managing which LEC joins which LES. The LECS provides a central point of contact on the network for LECs and LESs. During the boot process, the LEC sends the LECS a request for the type of ELAN it wants to join. The LECS responds with the current ATM address and configuration parameters of the LES that serves the requested ELAN.

When setting up LAN Emulation Servers and LAN Emulation Configuration Servers, keep in mind that each LECS must reside on the same ATM adapter as the LESs it serves. The LECS cannot communicate with LESs across the network.

Starting CellView

To start the CellView utility, enter the command `load cellview`

When you start CellView, the main CellView dialog box appears.

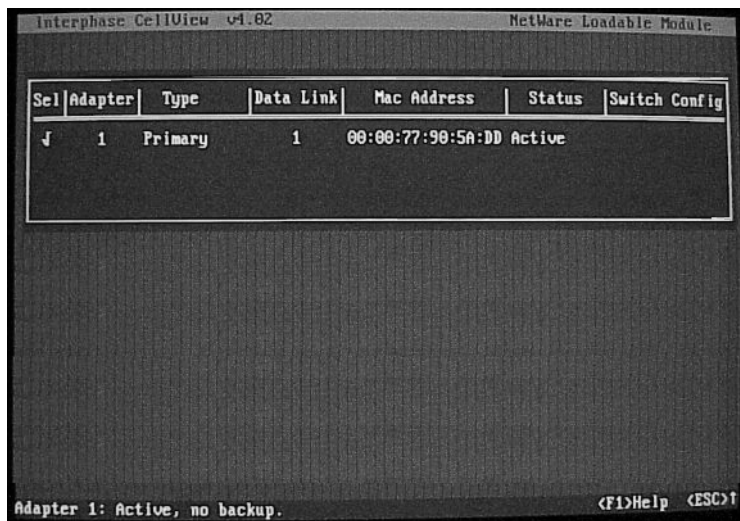

Figure 10-1. Main CellView Dialog Box



NOTE

If you have trouble starting CellView, make sure the `INETCFG.NCF` (NetWare 5.x) or `AUTOEXEC.NCF` (NetWare 3.x or 4.x) file includes the `LOAD cvconf` command.

Main CellView Information

The fields in the main CellView dialog box display information about the Interphase ATM adapters installed in the NetWare server. The following table describes the fields:

This field...	Provides the following information...
Sel	Enables you to select an adapter to work with.
Adapter	Adapter number, from 1 through 4.
Type	Type of adapter: primary or backup.
Data Link	<p>Active data link number. This is the number of the primary adapter for which cells are being transferred.</p> <p>For an active primary adapter, this field displays the adapter number. It is blank if the primary adapter is inactive or down.</p> <p>For an active backup adapter, this field displays the number of the primary adapter being backed up. It is blank if the backup adapter is available (not active) or down.</p>
MAC Address	<p>MAC address of the primary adapter for which cells are transferred.</p> <p>An active backup adapter uses the MAC address of the primary adapter number being backed up.</p> <p>This field is blank if the adapter is inactive.</p>
Status	<p>Connection status of the adapter.</p> <ul style="list-style-type: none"> • <i>Active</i> means the primary or backup adapter is active and transferring data. • <i>Down</i> means the primary or backup adapter has experienced a failure. • <i>Inactive</i> applies to primary adapters only. It means that the adapter has a good connection, but it is not active for data transfer. • <i>Available</i> applies to backup adapters only. It means that the adapter is not active, but is available to transfer data. <p>This field also provides redundancy information. For primary adapters, it identifies the backup adapter number. For backup adapters, it identifies the adapter being backed up.</p>

This field...	Provides the following information...
Switch Config	<p>Method for switching the data link from the backup adapter back to the primary adapter after a link failure is resolved. (This mode is set using the automatic switch-back setting on the Physical dialog box.)</p> <ul style="list-style-type: none"> • <code>Auto</code> indicates that the driver will automatically switch the data link to the primary adapter after link failure resolution. • <code>Manual</code> indicates that the end-user must switch the data link to the primary adapter after link failure resolution.

CellView Keyboard Commands

The keyboard commands available on the CellView dialog boxes enable you to perform actions that affect installed adapters and their network clients and servers. The following table describes the common CellView keyboard commands:

Press this key...	To do this...
F1 (Help)	Activate the Help dialog box.
F2 (Edit)	Change a Setup dialog box to edit mode.
F10 (Apply)	Send your changes to the driver for immediate, dynamic update.
TAB (Move)	<p>Move to the next tabbed dialog box.</p> <p>If in the edit mode in a Setup dialog box, move the cursor to the next edit field.</p>
Enter (Select)	<p>On the Main CellView dialog box, select the adapter you want to set up or monitor.</p> <p>If in the edit mode in a Setup dialog box, select a field to edit.</p>
LEFT or RIGHT ARROW	Move the cursor to the previous or next edit field in a Setup dialog box.
N or P	Select the next or previous unit (client or LES) on CellView Setup dialog boxes. The <code><N/P></code> unit option appears when multiple clients are initialized for the adapter.
ESC (Exit)	<p>Exit the current dialog box or the CellView utility.</p> <p>When you exit a Setup dialog box after making changes, you are prompted to commit updates. Selecting YES saves updates and sends them to the driver for immediate action. You do not have to reboot the machine for the changes to take effect.</p>

After you select an adapter, the following pop-up menu enables you to check statistics or set up network services:

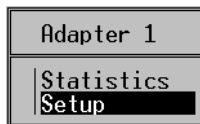

The following table describes the statistics and setup options:

Select...	To do this...
Statistics	Display the status of the following operations for the selected adapter: <ul style="list-style-type: none"> • signaling • AAL5 activity • LEC activity • Multi-Protocol over ATM (MPOA) activity • LES activity • LECS activity • CIP client and ARP server activity
Setup	Configure the following features for the selected adapter: <ul style="list-style-type: none"> • Physical features, such as framing, ATM VPI number, and redundancy • LECs • LEC PVC connections • LESs on the same adapter as the LECS • LECS on the same adapter as the LESs • CIP (1577) client and ARP server • CIP (1577) PVC connections

Setting Up ATM Network Services

Use CellView Setup tasks to configure ATM network services for the adapter. For primary adapters, you can configure settings for framing, redundancy, Virtual Path Identifier (VPI) address, clients, and servers. For backup adapters, you can configure framing and redundancy settings. When a backup adapter is activated, it inherits the remaining settings from the primary adapter it replaces.

You can configure up to 16 LECs, or fifteen LECs and one CIP client, on each primary adapter. The number of clients per adapter is specified during driver installation. (If you need to add clients, repeat the driver installation or configuration as instructed in the driver installation chapter for your system.)

You can also configure one LECS and up to eight LESs on each primary adapter. If you plan to enable the LECS and LESs, it is recommended that you configure them before configuring clients.

The following is a configuration overview. The topics in this section provide detailed information about each of these steps.

1. On the CellView dialog box, select the adapter to configure, and press **Enter**.
2. On the pop-up menu, select **Setup** and press **Enter**.
3. Use the Physical dialog box to ensure that the adapter's physical settings are correct. (See [Setting Up Physical Features on page 128](#) for instructions.)
4. **If the LES(s) and LECS will be on this machine**, use the LES and LECS dialog boxes to configure these servers. (See [Setting Up a LAN Emulation Server on page 138](#) and [Setting Up a LAN Emulation Configuration Server on page 139](#) for instructions.)
5. Use the LEC dialog box to configure the LECs specified for the adapter during driver installation. (See [Setting Up LAN Emulation Clients on page 130](#) for instructions.)
6. If an LEC will use PVC connections, create PVC table entries for the LEC. (See [Setting up LEC PVCs on page 134](#) for instructions.)
7. Use the CIP dialog box to configure the CIP client and ARP server, if specified during driver installation. (See [Setting up a CIP Client and Server on page 141](#) for instructions.)
8. If the CIP client will use PVC connections, create PVC table entries for the client. (See [Setting up CIP PVCs on page 142](#) for instructions.)
9. Exit CellView Setup.

When you exit CellView, your changes are saved in a system configuration file on your hard disk.

Setting Up Physical Features

Use the Physical dialog box set up the adapter's physical features, such as its framing type, VPI number, and redundancy features.

To set up the adapter's physical features:

1. On the main CellView dialog box, select the adapter and press **Enter**.
2. On the pop-up menu, select **Setup** to display the Physical dialog box.



Figure 10-2. Physical Setup

3. Provide physical information as follows:

Use this field...	To do this...
SUNI Framing	<p>Select the appropriate Framing mode:</p> <ul style="list-style-type: none"> • Select SONET (Synchronous Optical Network) to use the North American multiplexing standard to define the signal used in optical fiber networks. For ATM over fiber, OC-3c, with a base rate of 155.520 Mbps, is the most widely-used signal in the United States. • Select SDH (Synchronous Digital Hierarchy) to use the European multiplexing standard to define the signal used in optical fiber networks. STM-1 (Synchronous Transport Mode, Level 1) is the European equivalent of OC-3c. Like OC-3c, STM-1 has a base rate of 155 Mbps, but STM-1 has slightly different framing information than OC-3c.
VPI	<p>Identify the default Virtual Path Identifier to be used by all services on the adapter. The VPI is a one-byte field in the ATM cell header that, combined with the Virtual Circuit Identifier (VCI), forms an ATM address. You can enter a number from 0 (the default) to 255.</p>
Redundancy: Board Type	<p>Determine whether the adapter is a primary or backup adapter. Adapter 1 must be a primary adapter. Adapters 2–4 can be either primary or backup. For guidelines, see Redundant Link Support on page 123.</p>

Use this field...	To do this...
Redundancy: Backup Adapter No.	For a primary adapter, identify the backup adapter. To select a backup, more than one adapter must be installed. Adapter 1 must always be primary. For additional guidelines, see Redundant Link Support on page 123 .
Redundancy: Automatic Switch Back to Primary	For a primary adapter, enable automatic switch-back so that the driver will automatically reactivate the adapter and deactivate its backup adapter after a failure condition is resolved.

Setting Up LAN Emulation Clients

CellView provides a separate dialog box to set up each LEC initialized during driver installation. You can configure each LEC to establish SVC communications during the boot process via an LECS or an LES. You can also set up PVC links with other end stations.

To join an emulated LAN (ELAN), an LEC must contact an LES, which manages a specific ELAN's client connections. You can configure the LEC to directly contact an LES or to be routed to an appropriate LES through the LECS, which assigns LECs to LESs based on ELAN request parameters.

If the LESs and LECS will reside on the adapter, configure them before the LEC. For instructions, see [Setting Up a LAN Emulation Server on page 138](#) and [Setting Up a LAN Emulation Configuration Server on page 139](#). (For general information about the LES and LECS servers, see [LES and LECS Functions on page 124](#).)

PVC setup is explained in [Setting up LEC PVCs on page 134](#).

To set up an LEC:

1. On the main CellView dialog box, select the adapter and press **Enter**.
2. On the pop-up menu, select **Setup**, and then tab to **LEC** to display the LEC dialog box for LEC 1:



Figure 10-3. LEC Setup

3. If multiple LECs are initialized for the adapter and you want to edit a client other than LEC 1, press **N** (next) or **P** (previous) to move to the next or previous client.
4. Press **F2** to edit fields, and enter LEC information as follows:

Use this field...	To do this...
LEC Unit	View the LEC number.
MAC Address	View the MAC address of the LEC. LEC 1 is assigned the base address of the adapter. The remaining LECs use increments of the base address for their MAC addresses.
Enabled	Set to YES to enable the LEC. If using PVC-only activity, the client must be enabled for the driver to recognize the client.
PVC Only	Enable PVC-only activity for the client (and disable SVC activity). If you enable PVC-only activity, you must set up the PVC table as described in Setting up LEC PVCs on page 134 .

Use this field...	To do this...
Enable MPOA	<p>Enable Multi-protocol over ATM support. (Not available for Token Ring ELAN type.)</p> <p>MPOA is an ATM Forum standard that provides routing of legacy internetwork layer protocols (such as IP, IPX, AppleTalk) over ATM networks. MPOA allows LANE edge devices to perform internetwork layer forwarding and establish direct communications without requiring that LANE edge devices be full function routers. It separates the routing processing from the actual forwarding. (For additional information about MPOA, see MPOA Statistics on page 152.)</p> <p>If the LEC will use MPOA, the V2 Capable property must also be enabled. MPOA requires a LANE implementation that meets the minimal requirements of the <i>LAN Emulation Over ATM Version 2</i> specification.</p>
LANE V2 Capable	<p>Specify that the LEC can use SVCs in compliance with the LAN Emulation Version 2 specification.</p> <p>If the LEC will use ABR connections or the MPOA protocol, this property must be enabled.</p>
Enhanced VC	<p>Specify whether the network should maintain current, dynamic data VCs if the connection to the LES that established the VC links is lost.</p> <ul style="list-style-type: none"> • When enabled, any established, dynamic data VC links are maintained if the LES becomes inactive. • When disabled, any established, dynamic data VC links are torn down if the LES connection is lost.
SVC Default Rate	<p>Set the cell rate to use as the default for all SVC traffic on this LEC.</p> <ul style="list-style-type: none"> • Use the F3 key to select a unit of cells per second, kilobits per second, megabits per second, or bits per second. • Use the entry field to enter a specific cell rate. • Use the F9 key to select the line rate, which is the maximum rate available for the measurement unit.
ELAN Name	<p>Identify the network name of the emulated LAN you want the client to join.</p> <p>Some LAN emulation servers require a name while others do not. The Interphase LECS and LESs require a name only in the following cases:</p> <ul style="list-style-type: none"> • The Strict ELAN Name field is enabled on the LES dialog box. For more information LES setup, see Setting Up a LAN Emulation Server on page 138. • You need to differentiate between two or more LESs with the same MTU size and ELAN type. <p>For exact requirements, see your server documentation.</p>

Use this field...	To do this...
ELAN Type	<p>View the ELAN type (Ethernet or Token Ring). All nodes on the same logical subnet must use the same ELAN type.</p> <p>The ELAN type is determined by the ATM driver name (55X5SI for Ethernet or 55X5TSI for Token Ring) selected during installation. For information, see Installing the NetWare Integrated (Fat) Driver on page 109.</p>
MTU Size	<p>Select the LAN MTU size to request. The client uses this value when it requests to join an LES. The MTU returned to the client is equal to or less than the requested value.</p> <p>MTU settings are:</p> <ul style="list-style-type: none"> • For an ELAN with Ethernet edge device, select 1516 • For an ELAN with Ethernet edge device and with MPOA enabled, select 1580 • For an ELAN with Token Ring edge device, select 4544 • For an ELAN with ATM end stations only, select 9234 <p>All nodes on the same logical subnet must use the same MTU size. For a PVC-Only LEC, <code>MTU Size</code> must be compatible with the IP MTU of the network.</p>
LES/LECS Address: Address Type	<p>Each LEC that uses SVC communications connects to other clients via an LES. This option controls whether the LEC contacts the LES at startup directly or through the LECS.</p> <ul style="list-style-type: none"> • Select LES to have the client contact the LES directly. <p>OR</p> <ul style="list-style-type: none"> • Select LECS to have the client contact the LECS, which will route the LEC to the appropriate LES.

Use this field...	To do this...
LECS/LES Address: Network Prefix and ESI/Selector	<p>Use these fields together to identify the full ATM address of the LES or LECS to be contacted by the LEC at startup.</p> <ul style="list-style-type: none"> If the LEC will contact the LECS at startup, the entry defaults to the ATM Forum's well-known address. If you need to change the address, enter the ATM address of the LECS in the Network Prefix and ESI/Selector fields. If the LEC will contact the LES directly, enter the LES's ATM address. (This address is predetermined for the LES, usually as part of the switch setup.) <p>(For details about the address structure, see ATM Address on page 123. For information about LES and LECS setup, see Setting Up a LAN Emulation Server on page 138 and Setting Up a LAN Emulation Configuration Server on page 139.)</p>

Setting up LEC PVCs

Use the LEC PVC Table to set up PVC connections between an LEC and other network end stations.



NOTE

You must enable the LEC before you can set up PVC communications. Also, if the PVC Only parameter in the LEC dialog box is set to YES, make sure the LEC's MTU Size is set to the appropriate value for PVC communications (compatible with the IP MTU of the network).

To set up the LEC PVC Table:

1. If you have not done so, enable the LEC, as described in [Setting Up LAN Emulation Clients on page 130](#). Then exit the LEC dialog box.
2. Tab to **LEC PVC Table**.
3. If you want to edit a table other than for LEC 1, press **N** (next) or **P** (previous) to move to the next or previous client.
4. Press **F2** to display the PVC table for the client in edit mode.

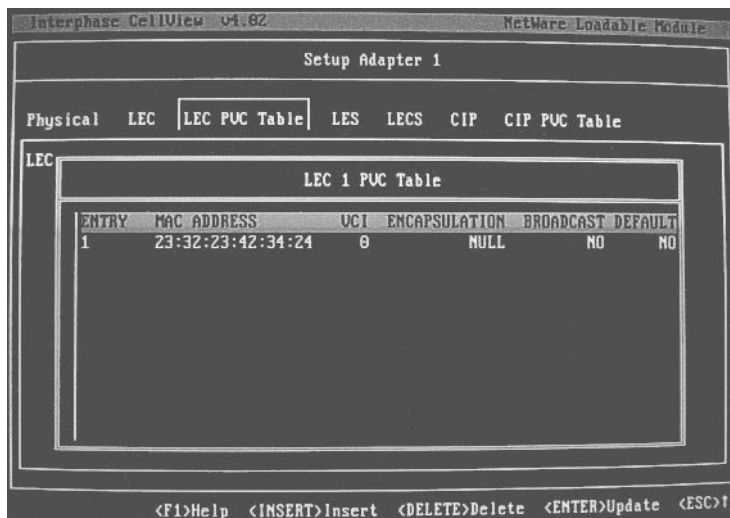

Figure 10-4. LEC PVC Table Setup

A 6-byte MAC address and a VCI number are associated with each PVC. Packets from the upper layers whose destination MAC address matches an address in the PVC table are transmitted on that PVC.

In addition to providing setup information in the PVC Table, you must also consider the following when configuring PVCs:

- All PVCs must be configured in the adapters and the switch(es) manually.
- The MAC address of the target station must be mapped to a VCI in the local host.
- The MAC address of the local client must be mapped to a VCI in the target station.

You can use the keyboard options to add, modify, or delete PVC table entries, as described in the topics that follow.

Adding or Modifying LEC PVC Entries

To add or modify PVCs for the LEC:

1. Press **Insert** to add a PVC entry; or to revise a PVC entry, highlight the entry and press **Enter**.

The following dialog box appears:



Figure 10-5. PVC Settings for LECs

2. Enter PVC settings as follows:

Use this field...	To do this...
MAC Address	Enter the 6-byte address of the target station to which the PVC will connect. Use the natural format for the ELAN. For example, for a Token Ring ELAN, use non-canonical format.
VCI	Enter the VCI number to be used by the LEC to communicate with the target. In most cases, the range is 32–1023 for 1K VC adapters, or 32–4095 for 4K VC adapters. (The corresponding VPI is configured on the Physical setup dialog box, as described in <i>Setting Up Physical Features</i> on page 128.)
Encapsulation	Select the encapsulation method (LLC_Snap or Null). The host and target must use the same encapsulation method. See <i>Multiprotocol Encapsulation over ATM AAL5</i> on page 274 for an explanation of these encapsulation methods.
Broadcast	Set to YES to enable the entry as a Broadcast PVC. If enabled, all broadcast/multicast packets from the upper layers are transmitted on this PVC. A maximum of 16 Broadcast PVCs can be enabled on each LEC.

Use this field...	To do this...
Rate	Set the cell rate to use for the PVC traffic. <ul style="list-style-type: none"> • Use the F3 key to select a unit of cells per second, kilobits per second, megabits per second, or bits per second. • Use the entry field to enter a specific cell rate. • Use the F9 key to select the line rate, which is the maximum rate available for the measurement unit.
Service	Select UBR or ABR service. ABR is available only if it is supported by the adapter.
Default PVC	Enable the PVC to get packets for unknown MAC addresses. Available when the LEC is in PVC-only mode.
MCR	For an adapter with ABR support, specify the Minimum Cell Rate in cells per second, kilobits per second, megabits per second, or bits per second.
ICR	For an adapter with ABR support, specify the Initial Cell Rate in cells per second, kilobits per second, megabits per second, or bits per second.
TBE	For an adapter with ABR support, specify the number of cells to use as the Transient Buffer Exposure.
FRTT	For an adapter with ABR support, specify the Fixed Round Trip Time in micro seconds.
NRM	For an adapter with ABR support, specify the maximum Number of cells for each forward RM Cell.
TRM	For an adapter with ABR support, specify the Time between forward RM Cells in milli-seconds.
ADTF	For an adapter with ABR support, specify, the Allowed Cell Rate (ACR) Decrease Time Factor.
CDF	For an adapter with ABR support, select the Cutoff Decrease Factor.
RIF	For an adapter with ABR support, select the Rate Increment Factor.
RDF	For an adapter with ABR support, select the Rate Decrement Factor.

Deleting LEC PVC Entries

To delete a PVC table entry, highlight the entry and press **Delete**.

Setting Up a LAN Emulation Server

A LAN Emulation Server (LES) is the central server for an associated ELAN. The LES provides address registration, address resolution, and broadcast services for all ELAN members. When an LEC joins an LES, the client's MAC-ATM address relationship is registered with the LES. The LES maintains a running account of these addresses to resolve ELAN members' queries. The connection between the LES and the LEC is a permanent, open one as long as the client is running.

The LES maintains a table of client information to provide ELAN address resolution services. When an end station is disconnected or turned off, the LES automatically removes clients from the table. Therefore, relocating an end station only involves physically moving the hardware and connecting it to the same or another ATM switch. During the boot process, the clients rejoin the LES with a new ATM address.

CellView provides a separate dialog box for each LES-ELAN setup. To set up an LES:

1. On the CellView dialog box, select the adapter and press **Enter**.
2. On the pop-up menu, select **Setup**, and then tab to **LES**.

The LES dialog box appears for LES 1.



Figure 10-6. LES Setup

3. If you want to set up an LES other than LES 1, press **N** (next) or **P** (previous) to move to the next or previous LES.
4. Press **F2** to edit fields, and enter LES information as follows:

Use this field...	To do this...
Enabled	Set to YES to enable the LES.

Use this field...	To do this...
ELAN Name	Enter the name of the ELAN for which the LES provides services (not required for a LEC to join the group, but may be needed if a LEC is to request this ELAN among a group of similarly configured ELANs). If the Strict ELAN Name field (on this dialog box) is set to YES, the ELAN name in the LEC request must exactly match this name (case sensitive) for the LEC to join the group.
ELAN Type	View the ELAN type (Ethernet or Token Ring) to use for all communications between end stations. The ELAN type is determined by the ATM driver name (55X5SI for Ethernet or 55X5TSI for Token Ring) selected during installation. For information, see Installing the NetWare Driver on page 107 .
ELAN MTU Size	View the MTU size of the ELAN for which the LES provides services. Settings for different ELAN types are as follows: <ul style="list-style-type: none"> • For an ELAN with Ethernet edge device: 1516 • For an ELAN with Ethernet edge device and with MPOA enabled: 1580 • For an ELAN with Token Ring edge device: 4544 • For an ELAN with ATM end stations only: 9234
Strict ELAN Name	Set to YES to specify that the ELAN Name in the LEC's request must exactly match the entry in the ELAN Name field on this dialog box (case sensitive).
Strict MTU Size	Set to YES to specify that the ELAN MTU Size in the LEC's request must exactly match the entry in the ELAN MTU Size field on this dialog box.

Setting Up a LAN Emulation Configuration Server

The LAN Emulation Configuration Server (LECS) is a server that manages LESs on a network. The LECS manages which LEC joins which LES (which is the central server for an ELAN). The LECS provides a central point of contact for each LEC on the network. During the boot process, the LEC sends the LECS a request for the type of ELAN it wants to join. The LECS responds with the current ATM address and configuration parameters of the LES that serves the requested ELAN.

The LECS must reside on the ATM adapter with the LESs it serves; it cannot communicate with LESs across the network.

To set up the LECS:

1. On the CellView dialog box, select the adapter and press **Enter**.

2. On the pop-up menu, select **Setup**, and then tab to **LECS** to display the LECS dialog box.

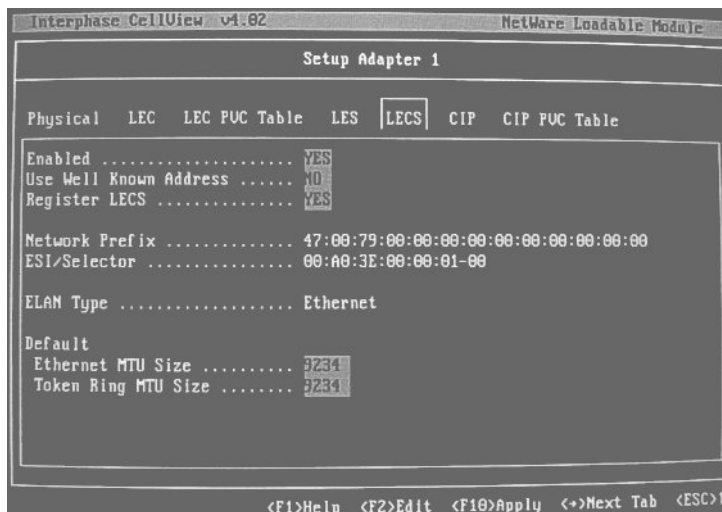

Figure 10-7. LECS Setup

3. Press **F2** to edit fields, and enter LECS information as follows:

Use this field...	To do this...
Enabled	Set to YES to enable the LECS and all permanent mappings of LECs to specific LESs.
Use Well Known Address	Set to YES to enable the ATM Forum's well-known address to be loaded to the Network Prefix and ESI/Selector fields as the LECS's ATM address. This feature is enabled by default. If enabled, the well-known address will override a manually entered Network Prefix and ESI/Selector address.
Register LECS	Set to YES to register the ATM address in the Network Prefix and ESI/Selector fields with the switch during the boot process.
Network Prefix and ESI/Selector	If the LECS's ATM address differs from the ATM Forum's well-known address, enter the LECS's ATM Network Prefix and ESI/Selector values.
ELAN Type	View the default ELAN type (Ethernet or Token Ring) to assign to LEC requests.
Default: Ethernet MTU Size	Select the default Ethernet ELAN MTU size to assign to an LEC if the LEC's configuration request omits the MTU size (1516, 4544, 9234).
Default: Token Ring MTU Size	Select the default Token Ring ELAN MTU size to assign to an LEC if the LEC's configuration request omits the MTU size (1516, 4544, 9234).

Setting up a CIP Client and Server

The CIP client conforms to the RFC 1577 specification using Classical IP-over-ATM (CIP) where no multicast or broadcast services are available.

Using the CIP dialog box, you can enable the CIP client and enable the host adapter as the Address Resolution Protocol (ARP) server for the network. After you enable the client, you can also enable SVC and PVC communications or PVC-only communications. PVC setup is explained in [Setting up CIP PVCs on page 142](#).

To set up a CIP client/ARP server configuration:

1. On the CellView dialog box, select the adapter and press **Enter**.
2. On the pop-up menu, select **Setup**, and then tab to **CIP** to display the CIP dialog box.

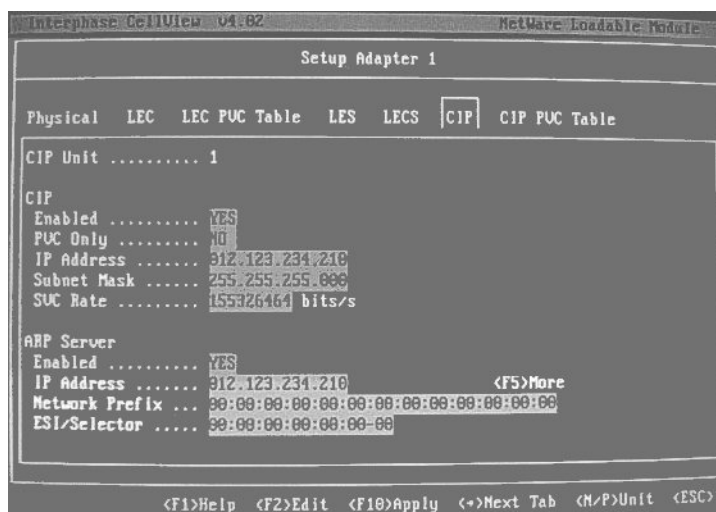

Figure 10-8. CIP Setup

3. Press **F2** to edit fields, and enter CIP information as follows:

Use this field...	To do this...
Enabled	Set to YES to enable the CIP client. If using PVC-only activity, the client must be enabled for the driver to recognize the client.
PVC Only	Enable PVC-only activity for the client (and disable SVC activity). If you select to enable PVC-only activity, you must set up the PVC table as described in Setting up CIP PVCs on page 142 . This is the only other setting required for PVC-only clients.
IP Address	Enter the client's IP address.
Subnet Mask	Enter the client's subnet mask identifier.

Use this field...	To do this...
SVC Rate	<p>Set the cell rate to use as the default for SVC traffic</p> <ul style="list-style-type: none"> • Use the F3 key to select a unit of cells per second, kilobits per second, megabits per second, or bits per second. • Use the entry field to enter a specific cell rate. • Use the F9 key to select the line rate, which is the maximum rate available for the measurement unit.
ARP Server: Enabled	<p>Set to YES to enable the host adapter as the ARP server for your CIP network.</p>
ARP Server: IP Address	<p>If the host adapter is not the ARP server, enter the IP address of the ARP server located elsewhere in the network.</p> <p>Press F5 (More) to add or modify the IP address, Network Prefix, or ESI/Selector for other ARP servers.</p>
ARP Server: Network Prefix and ESI/Selector	<p>If the host adapter is not the ARP server, enter the ARP server's ATM address, which consists of the Network Prefix and ESI/Selector. (For details about the address structure, see ATM Address on page 123.)</p> <p>The CIP driver must know the ATM address of the ARP server. When the system is powered up, it calls the ARP server with this ATM address.</p> <p>Press F5 (More) to add or modify the IP address, Network Prefix, or ESI/Selector for other ARP servers.</p>

Setting up CIP PVCs

Use the CIP PVC Table to set up PVC connections between the local CIP client and other end stations on the network.



NOTE

You must enable the CIP client before you can set up PVC communications.

To set up the CIP PVC Table:

1. If you have not done so, enable the CIP client, as described in [Setting up a CIP Client and Server on page 141](#). Then exit the CIP dialog box.
2. Tab to **CIP PVC Table**.
3. Press **F2** to display the CIP PVC Table dialog box in edit mode.



Figure 10-9. CIP PVC Table Setup

An IP address and VCI number are associated with each PVC. Packets from the upper layers whose destination addresses match an address in the PVC table are transmitted on that PVC.

In addition to providing setup information in the PVC Table, you must also consider the following when configuring PVCs for the CIP client:

- All PVCs must be configured in the adapters and the switch(es) manually.
- The IP address of the target station must be mapped to a VCI in the local host.
- The IP address of the local client must be mapped to a VCI in the target station.

You can use the keyboard options to add, modify, or delete PVC table entries, as described in the topics that follow.

Adding or Modifying CIP PVC Entries

To add or modify PVC table entries for a CIP client:

1. Press **Insert** to add a PVC entry; or to revise a PVC entry, highlight the entry and press **Enter**.

The following dialog box appears:



Figure 10-10. PVC Settings for CIP Clients

2. Enter CIP PVC table information as follows:

Use this field...	To do this...
IP Address	Enter the IP address of the target station to which the PVC will connect.
VCI	Enter the Virtual Circuit Identifier number to be used by the CIP client to communicate with the target. In most cases, the range is 32–1023 for 1K VC adapters, or 32–4095 for 4K VC adapters. (The corresponding VPI is configured on the Physical setup dialog box, as described in Setting Up Physical Features on page 128.)
Encapsulation	Select the encapsulation method (LLC_Snap or Null). The host and target must use the same encapsulation method. See Multiprotocol Encapsulation over ATM AAL5 on page 274 for an explanation of these encapsulation methods.
Service	Select UBR or ABR service. ABR is available only if it is supported by the adapter.
Rate	Set the cell rate to use for the PVC traffic. <ul style="list-style-type: none"> • Use the F3 key to select a unit of cells per second, kilobits per second, megabits per second, or bits per second. • Use the entry field to enter a specific cell rate. • Use the F9 key to select the line rate, which is the maximum rate available for the measurement unit.

Deleting CIP PVC Entries

To delete a PVC table entry, highlight the entry, and press **Delete**.

Statistics Information

The CellView Statistics function provides information that can help you troubleshoot network problems and check for proper driver operation. Statistics dialog boxes display network statistics for the clients and servers on the Interphase ATM adapter(s) installed in an end station. When the end station boots up, certain communications must occur between the client and the server (through the switch) so the client can log onto the network. Statistics routines monitor the state of client and server communications, signaling, and AAL5 traffic.

CellView gathers network operation statistics for local Interphase clients and servers only. It does not gather statistics from switches or from other end stations.

CellView provides the following sets of statistics:

- signaling, described in the next topic, [signaling Statistics](#)
- AAL5, described in [AAL5 Statistics on page 148](#)
- LEC, described in [LEC Statistics on page 149](#)
- MPOA, described in [MPOA Statistics on page 152](#)
- CIP, described in [CIP Statistics on page 160](#)
- LES, described in [LES Statistics on page 163](#)
- LECS, described in [LECS Statistics on page 165](#)

If you find an item in error, the driver might be incorrectly installed or configured. If you suspect a problem with your driver setup, see [Troubleshooting on page 167](#).

signaling Statistics

To display statistics about the signaling on an adapter, on the main CellView dialog box, select the adapter, and then select **Statistics** on the pop-up menu. The Sig dialog box is displayed:

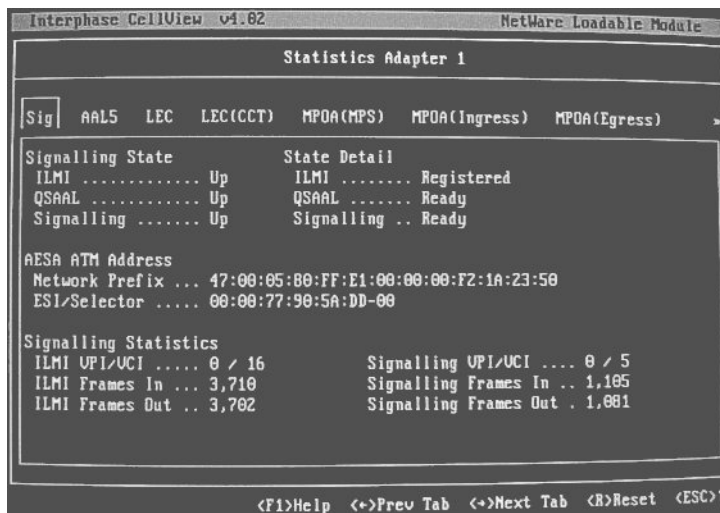

Figure 10-11. signaling Statistics

3. Check the following signaling indicators:
 - In the signaling State fields, the ILMI, QSAAL, and signaling values should all read as **up**.
 - In the State Detail fields, the ILMI, QSAAL, and signaling values should be similar to:
 - ILMI: **Registered**
 - QSAAL: **Ready**
 - signaling: **Ready**
 - In the signaling Statistics fields, the Frames In and Frames Out values should indicate traffic.

If any of the signaling State values are not **up** and statistics indicate a lack of traffic, make sure that the UNI Revision and other settings on the signaling Setup dialog box correspond to the settings of your switch.



NOTE

If PVC-only connections are used for all clients, it is normal for signaling states to be inactive.

Following is detailed signaling statistics information:

Field/Field Group	Description
signaling State	<p>State of the following signaling items:</p> <ul style="list-style-type: none"> • ILMI— Integrated Local Management Interface, which queries the ATM switch at startup and synchronizes to the switch's UNI signaling revision. • QSAAL—signaling ATM Adaptation Layer, which provides reliable transport of ATM switch and host messages over the ATM layer. • signaling <p>Values indicate the following:</p> <ul style="list-style-type: none"> – Up indicates active. – Down indicates inactive.
State Detail	Brief explanation of the ILMI, QSAAL, and signaling state.
AESA ATM Station Address	Network Prefix and ESI Selector Value parts of the end station's ATM Address.
signaling Statistics	<p>Information for each signaling item:</p> <ul style="list-style-type: none"> • Virtual Path Identifier and Virtual Circuit Identifier used • Number of frames received • Number of frames sent

AAL5 Statistics

To display statistics about activity on an adapter's AAL5 layer, on the main CellView dialog box, select the adapter and select **Statistics** on the pop-up menu. Then select the **AAL5** tab:

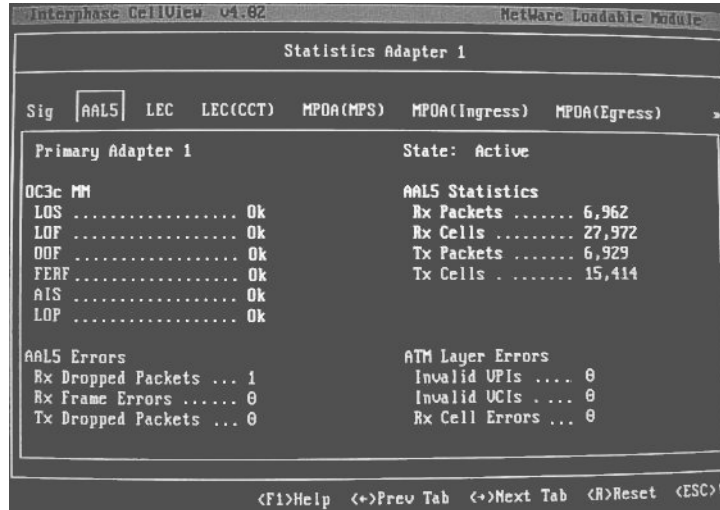

Figure 10-12. AAL5 Statistics

Check the following AAL5 indicators:

- All six of the OC3c MM fields should read **ok**.
- The AAL5 Statistics fields should indicate traffic.

If any of OC3c MM fields do not read **ok** and statistics indicate a lack of traffic, a failure occurred somewhere in the cable or connectors.

Following is detailed AAL5 statistics information:

Field/Field Group	Description
Adapter	Adapter type (primary or backup) and adapter number.
State	Adapter state (active, down, inactive, or available).

Field/Field Group	Description
OC3c MM	<p>Status of error conditions used to monitor transmissions over the OC-3 optical fiber. In each case, OK indicates that the error has not occurred, and a brief description identifies an error that has occurred.</p> <ul style="list-style-type: none"> • LOS—Loss of Signal. Indication that the receiving equipment has lost the received signal. Used to monitor the performance of the PHY layer. • LOF—Loss of Frame. Indication that the receiving equipment has lost frame delineation. Used to monitor the performance of the PHY layer. • OOF—Out of Frame. Like LOF, indication that the receiving equipment has lost frame delineation. Used to monitor the performance of the PHY layer. • FERF—Far End Receive Failure. Indication of disconnection of the transmit path, though the receive path may be functional. • AIS—Alarm Indication Signal. Indication to the receiving equipment that a transmission interruption occurred either at the equipment originating the AIS signal, or upstream of the originating equipment. Transmitted instead of the normal signal to maintain transmission continuity. • LOP—Loss of Pointer. Indication that the receiving equipment has lost the pointer to the start of cell in the payload. Used to monitor the performance of the PHY layer.
AAL5 Statistics	Number of packets received, cells received, packets transmitted, and cells transmitted across the AAL5 layer.
AAL5 Errors	Number of errors in the AAL5 layer. Number of packets dropped and frame errors detected on receive and number of packets dropped on transmit.
ATM Layer Errors	Number of errors in the ATM layer. Number of invalid VPIs, invalid VCIs, and receive cell errors detected.

LEC Statistics

There are two sets of LEC statistics. You can view general information about the LEC configuration and control traffic as described in the next topic, [General LEC Information](#). You can view details about client connections and communication traffic as described in [LEC Client Connection Table \(CCT\) Statistics on page 151](#).

General LEC Information

To display general statistics for a LEC enabled on an adapter:

1. On the main CellView dialog box, select the adapter and select **Statistics** on the pop-up menu. Then select the **LEC** tab.

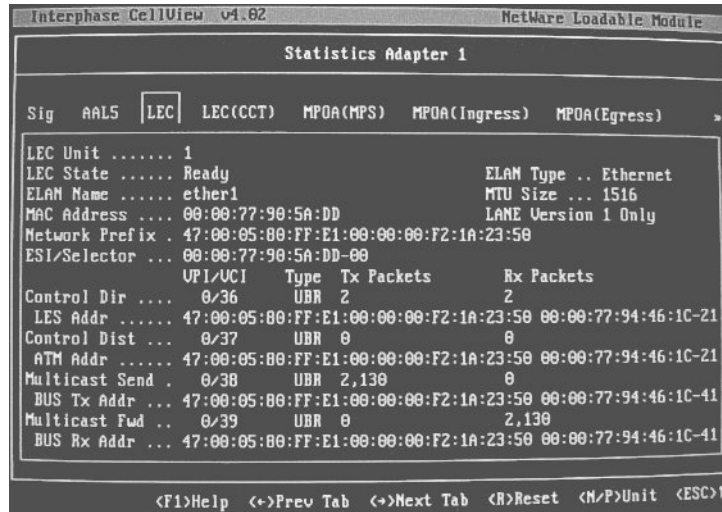

Figure 10-13. LEC Statistics

2. Select the LEC (using **N** for next, or **P** for previous), and check the LEC State field.

Check the following LEC indicators:

- The State field should read **ready** to indicate that the LEC is active.
- The Tx Packets and Rx Packets fields should indicate traffic.

If the LEC state is not ready and statistics indicate a lack of traffic, make sure that the settings on the LEC setup dialog box correspond to your switch and ELAN. Also make sure that LES and/or LECS parameters are correct on the LEC setup dialog box.

Following is detailed LEC statistics information:

Field/Field Group	Description
LEC	LEC information: <ul style="list-style-type: none"> • LEC number • LEC state (ready, idle, active, terminal) • Type of ELAN the LEC is assigned to • Name of the ELAN the LEC is assigned to • MTU size of the LEC • LEC MAC address • LANE version of the LEC • ATM Network Prefix and ESI/Selector address of the LES or LECS the LEC connects to during the boot process

Field/Field Group	Description
Control and Multicast Traffic Statistics	<p>VPI/VCI number, bit rate type, number of transmitted packets, number of received packets, and MAC Address for each of the following channels:</p> <ul style="list-style-type: none"> • Control Dir—Control Direct VCC, bi-directional point-to-point VCC between the LEC and the LES for sending control traffic. • Control Dist—Control Distribute VCC, unidirectional point-to-point or point-to-multipoint control VCC between the LES and the LEC for distributing control traffic. • Multicast Send—Bi-directional point-to-point VCC between the LEC and the BUS used to transmit multicast data to the BUS and for sending initial unicast data. • Multicast Forward—Point-to-multipoint VCC or unidirectional point-to-point VCC between the BUS and LEC used to distribute data from the BUS to the LEC. Must be established for a LEC to participate in the ELAN.

LEC Client Connection Table (CCT) Statistics

To check client connection statistics for a LEC enabled on an adapter:

1. On the main CellView dialog box, select the adapter and select **Statistics** on the pop-up menu. Then select the **LEC** tab.
2. On the LEC dialog box, select the LEC (using **N** for next, or **P** for previous).
3. Select the **LEC (CCT)** tab.

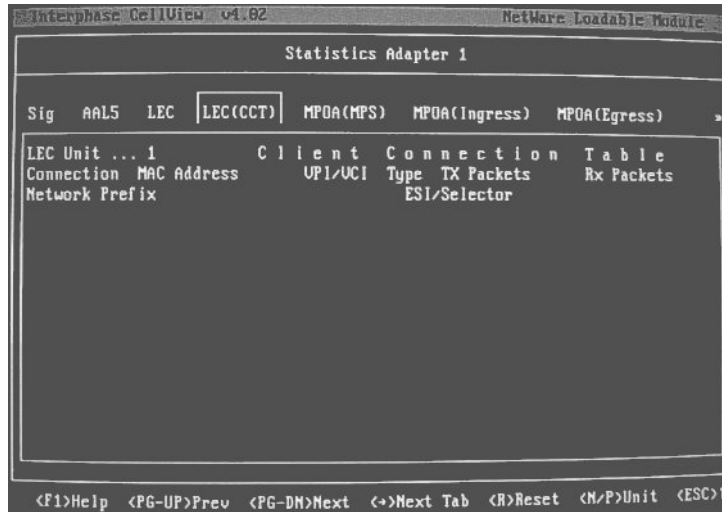

Figure 10-14. LEC (CCT) Statistics

The Tx Packets and Rx Packets fields (on the first line of each listed connection) should indicate traffic. If these fields indicate a lack of traffic, make sure that the settings on the LEC setup dialog box correspond to your switch and ELAN. Also make sure that LES and/or LECS parameters are correct on the LEC setup dialog box.

Following is detailed LEC Client Connection Table statistics information:

Field/Field Group	Description
LEC Unit	LEC number
Client Connection Table	Information about each LEC connection: <ul style="list-style-type: none"> • Connection number • MAC Address and VPI/VCI number of the target client • Connection bit rate type • Number of transmitted packets • Number of received packets • Network Prefix and ESI/Selector values of the target client's ATM address

MPOA Statistics

MPOA (Multi-Protocol over ATM) is an ATM Forum standard that provides routing of legacy internetwork layer protocols (such as IP, IPX, AppleTalk) over ATM networks. MPOA requires a LANE implementation that complies with the *LAN Emulation Over ATM Version 2* specification.

MPOA separates routing processing from forwarding. It integrates LANE with Next Hop Resolution Protocol (NHRP). NHRP provides an extended address resolution protocol that enables inter-subnet communication without requiring routers in the data path. Where

communicating LAN devices are behind LANE edge devices, MPOA allows the edge devices to perform internetwork layer forwarding and establish direct communications without being full function routers.

An MPOA system consists of inter-communicating MPOA Clients (MPCs) and MPOA Servers (MPSs). MPCs connect directly to each other across an MPOA system to forward internetwork layer packets over shortcuts, bypassing the packets' default routed LANE path. MPSs are logical components of routers that provide internetwork forwarding information to MPCs, enabling the shortcut connections. An MPOA-enabled LEC on the adapter communicates with one MPC (which can serve multiple LECs) to perform high-speed internetwork packet forwarding.

MPCs and the MPSs that serve them have an ingress role at the point where internetwork layer packets enter the MPOA system and an egress role at the MPOA system exit point.

In the ingress role, an MPC detects data packets entering the MPOA system and issues resolution requests to a corresponding ingress MPS for a shortcut address. The ingress MPS communicates with an egress MPS (based on the packet destination address), which finds the appropriate egress MPC to receive and send on the packets. The ingress MPS receives the shortcut address information from the egress MPS and sends the information in a resolution response to the ingress MPC. The MPC caches the information in its ingress cache, sets up a shortcut VCC, and forwards frames over the shortcut to the egress MPC.

In the egress role, an MPC receives internetwork data frames from other MPCs to be forwarded to its local interfaces/users. For frames received over a shortcut, the MPC adds appropriate DLL encapsulation and forwards them to the higher layers. The DLL encapsulation information is provided by an egress MPS in an MPOA Cache Imposition Request (resulting from its communication with the ingress MPS), and stored in an entry in the MPC's egress cache.

For detailed information, see the ATM Forum's *Multi-Protocol Over ATM* specification. (The ATM Forum's Web address is <http://www.atmforum.com>.)

There are several sets of MPOA statistics:

- MPS statistics, described in the next topic, *MPOA (MPS)*
- Ingress statistics, described in *MPOA (Ingress)* on page 155
- Egress statistics, described in *MPOA (Egress)* on page 156
- VCC statistics, described in *MPOA (VCC)* on page 158.
- MPOA Counter statistics, described in *MPOA Counters* on page 159.

MPOA (MPS)

To display MPOA MPS statistics for a LEC enabled on the adapter:

1. On the main CellView dialog box, select the adapter and select **Statistics** on the pop-up menu. Then select the **MPOA (MPS)** tab.



Figure 10-15. MPOA (MPS) Statistics

2. On the MPOA (MPS) dialog box, select the LEC (using **N** for next, or **P** for previous).

Following is detailed MPS statistics information:

Field/Field Group	Description
LEC Unit	LEC number.
MPS Servers Discovered table	Information about MPSs discovered on the network by the MPC associated with the LEC: <ul style="list-style-type: none"> • MAC address of the MPS • ATM Address of the MPS • Keep Alive messages received from the MPS to notify the MPC that the MPS is alive and able to supply and maintain ingress or egress cache entries

MPOA (Ingress)

To display MPOA Ingress statistics for a LEC enabled on the adapter:

1. On the main CellView dialog box, select the adapter and select **Statistics** on the pop-up menu. Then select the **MPOA Ingress** tab.

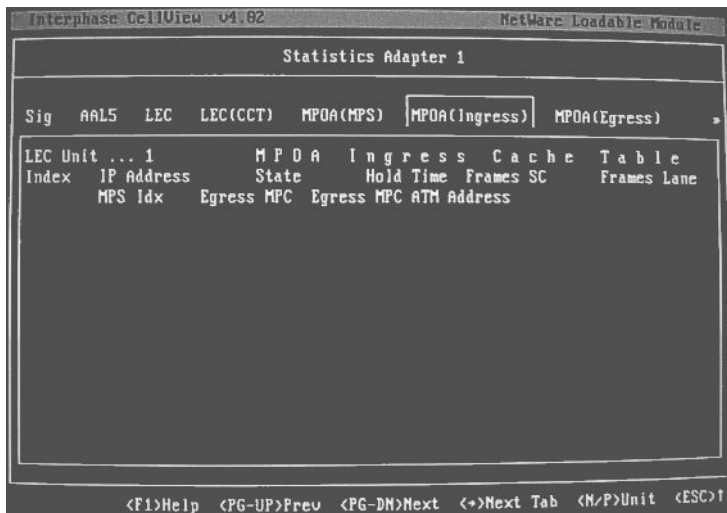

Figure 10-16. MPOA (Ingress) Statistics

2. On the MPOA (Ingress) dialog box, select the LEC (using **N** for next, or **P** for previous).

Following is detailed MPOA Ingress statistics information:

Field/Field Group	Description
LEC Unit	LEC number.

Field/Field Group	Description
MPOA Ingress Cache Table	<p>Information about the ingress cache entries for the MPC associated with the LEC:</p> <ul style="list-style-type: none"> • Index number of the ingress cache entry • Destination IP Address of the packets in the data flow • State of the ingress cache entry • Hold Time during which the entry is allowed to remain in the cache before being deleted • Frames SC—Number of frames forwarded over a shortcut to an egress MPC • Frames Lane—If a shortcut is not used, number of LANE data frames forwarded to the destination. • Index number of the ingress MPS handling the MPOA Resolution Request for shortcut • Egress MPC at the other end of the shortcut receiving packets from this MPC to forward to its local interfaces/users. • ATM address of the Egress MPC at the other end of a shortcut (used as the Called Party Address while setting up a shortcut VCC)

MPOA (Egress)

To display MPOA Egress statistics for a LEC enabled on the adapter:

1. On the main CellView dialog box, select the adapter and select **Statistics** on the pop-up menu. Then select the **MPOA Egress** tab.



Figure 10-17. MPOA (Egress) Statistics

2. On the MPOA (Egress) dialog box, select the LEC (using **N** for next, or **P** for previous).

Following is detailed MPOA Egress statistics information:

Field/Field Group	Description
LEC Unit	LEC number.
MPOA Egress Cache Table	<p>Information about egress cache entries for the MPC associated with the LEC:</p> <ul style="list-style-type: none"> • Index number of the egress cache entry • State of the egress cache entry (resolved, purge, invalid). Packets received over shortcuts are forwarded only when the entry is in resolved state. • Hold Time during which the entry is considered valid in the cache before being deleted • Index of the egress MPS sending the MPOA Cache Imposition Request to the egress MPC • Number of packets received from the ingress MPC to be forwarded to the local interface • Cache ID used as a key in combination with the requesting ingress ATM address to identify the egress cache entry. • ATM address of the ingress MPC that issued the MPOA Resolution request that resulted in imposition of this cache entry (Calling Party Address of an incoming shortcut VCC Setup Request) • DLL Header attached to the internetwork layer packet being forwarded

MPOA (VCC)

To display MPOA VCC statistics for a LEC enabled on the adapter:

1. On the main CellView dialog box, select the adapter and select **Statistics** on the pop-up menu. Then select the **MPOA VCC** tab.

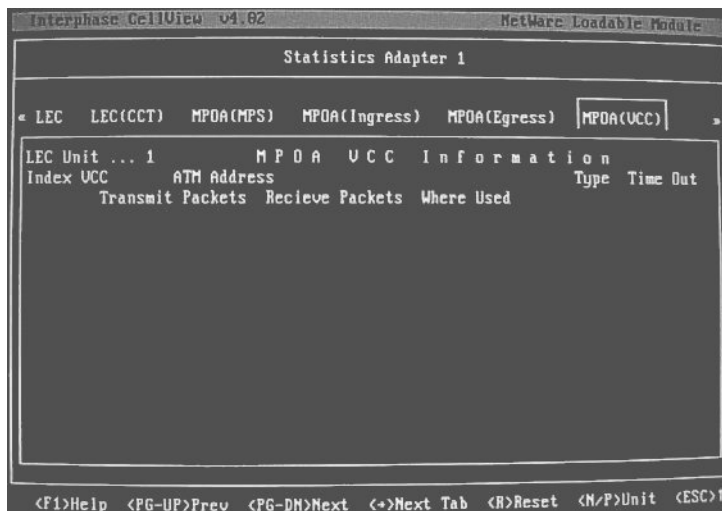

Figure 10-18. MPOA (VCC) Statistics

2. On the MPOA VCC dialog box, select the LEC (using **N** for next, or **P** for previous).

Following is detailed MPOA VCC statistics information:

Field/Field Group	Description
LEC Unit	LEC number.
MPOA VCC Information	Information about the VCCs used by the MPC associated with the LEC: <ul style="list-style-type: none"> • VCC index number • VCC used to send internetwork layer packets from the ingress MPC to the egress MPC • Destination ATM Address to which the VCC connects • Code that indicates the packet type of the traffic carried on the VCC • Time after which the VCC will idle out due to inactivity • Number of packets transmitted on the VCC • Number of packets transmitted on the VCC

MPOA Counters

To display details about MPOA counters for an adapter and for a LEC enabled on the adapter:

1. On the main CellView dialog box, select the adapter and select **Statistics** on the pop-up menu. Then select the **MPOA Cntrs** tab.

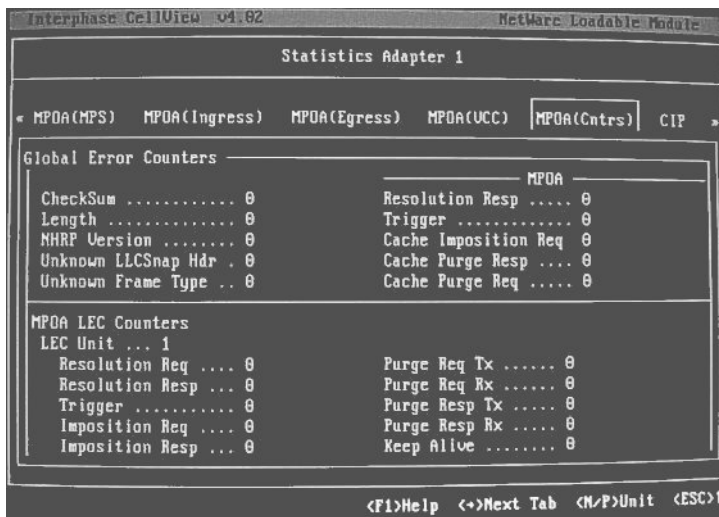

Figure 10-19. MPOA Counter Statistics

2. On the MPOA Cntrs dialog box, select the LEC unit (using **N** for next, or **P** for previous).

Following is detailed MPOA Counter statistics information:

Field/Field Group	Description
LEC Unit	LEC number.
Global Error Counters	<p>Number of the following types of packet errors for all MPCs communicating with LECs on the adapter:</p> <ul style="list-style-type: none"> • CheckSum failure • Length validity • Next Hop Resolution Protocol Version compatibility • Unknown LLC Snap (Logical Link Control/SubNetwork Attachment Point) Header • Unknown Frame Type

Field/Field Group	Description
MPOA	Number of the following types of MPOA-specific errors for all MPCs communicating with LECs on the adapter: <ul style="list-style-type: none"> • Resolution Response • Trigger (sent when an MPS determines the need for an inbound data flow shortcut, to trigger an ingress MPC into initiating an MPOA Resolution Request). • Cache Imposition Request • Cache Purge Response • Cache Purge Request
MPOA LEC Counters	Number of the following types of messages received/sent by the MPC communicating with the selected LEC: <ul style="list-style-type: none"> • MPOA Resolution Requests transmitted by the MPC (in ingress role) to MPSs • MPOA Resolution Responses received from ingress MPSs • MPOA Triggers received from ingress MPSs • MPOA Cache Imposition Requests received by the MPC (in egress role) from MPSs • MPOA Cache Imposition Responses sent by the MPC to egress MPSs • Purge Requests transmitted to MPSs • Purge Requests received from MPSs • Purge Responses transmitted to MPSs • Purge Responses received from MPSs • Keep Alive messages received from MPSs

CIP Statistics

There are two sets of CIP statistics. You can view general information about the CIP configuration and control traffic as described in the next topic, [General CIP Information](#). You can view details about client connections and communication traffic as described in [CIP Connection Table \(CT\) Information on page 162](#).

General CIP Information

To display general statistics for a CIP enabled on an adapter, on the main CellView dialog box, select the adapter. Then select **Statistics** on the pop-up menu, and select the **CIP** tab.

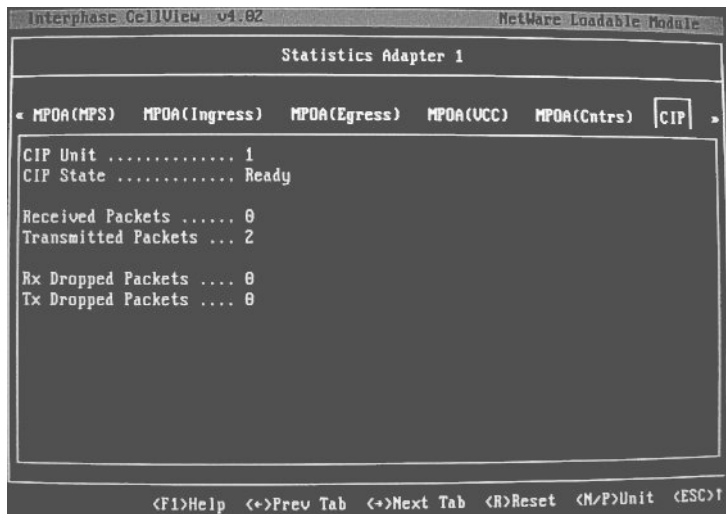

Figure 10-20. CIP Statistics

Check the following CIP indicators:

- The CIP State field should read **Ready** to indicate that the CIP client is active.
- The Received Packets and Transmitted Packets fields should indicate traffic.

If the CIP state is not ready and statistics indicate a lack of traffic, make sure that the settings on the CIP setup dialog box correspond to your switch.

Following is detailed CIP statistics information:

Indicators	Description
CIP Unit	CIP client number.
CIP State	Activity state of the CIP client.
Received and Transmitted	Number of packets received and transmitted by the CIP client.
Dropped Packets	Number of packets dropped by the CIP client during receive activity and transmission activity.

CIP Connection Table (CT) Information

To display traffic statistics for the connections of a CIP client enabled on an adapter, on the main CellView dialog box, select the adapter. Then select **Statistics** on the pop-up menu, and select the **CIP(CT)** tab.

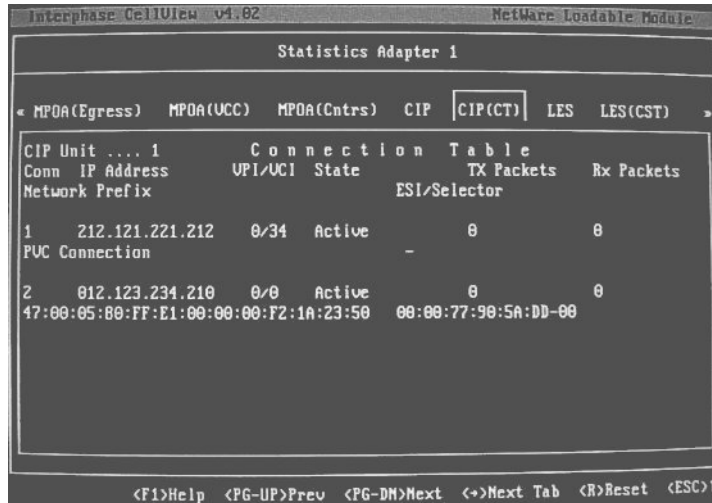

Figure 10-21. CIP (CT) Statistics

The Tx Packets and Rx Packets fields should indicate traffic.

If the State is not ready and statistics indicate a lack of traffic, make sure the settings on the CIP setup dialog box correspond to your switch.

Following is detailed CIP Connection Table statistics information:

Indicators	Description
CIP Unit	CIP client number.
Connection Table	Information about CIP client connections: <ul style="list-style-type: none"> • Connection number • IP Address of the target client • VPI and VCI of the connection • State of the connection • Number of packets transmitted on the connection • Number of packets received on the connection • Network Prefix and ESI/Selector values of the connected client's ATM address (or indication of a PVC connection)

LES Statistics

There are two sets of LES statistics. You can view general information about the LES configuration as described in the next topic, *General LES Information*. You can view details about LES connections and traffic as described in *LES Client Service Table Statistics* on page 164.

General LES Information

To display general statistics for an LES enabled on an adapter:

1. On the main CellView dialog box, select the adapter and select **Statistics** on the pop-up menu. Then select the **LES** tab.

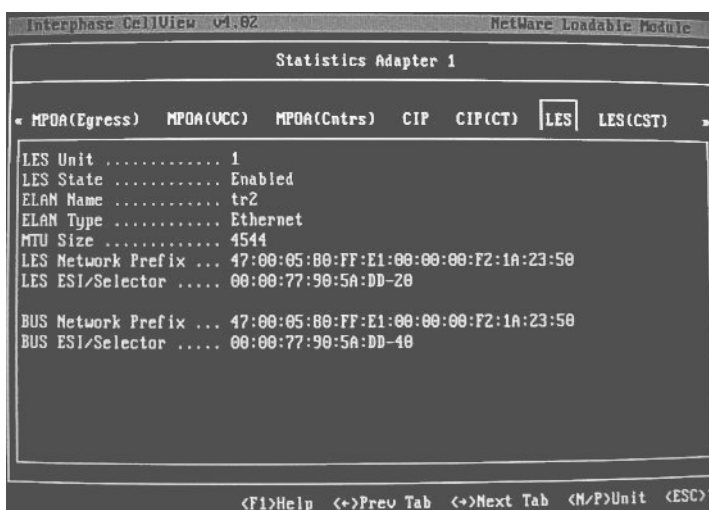

Figure 10-22. LES Statistics

2. Select an LES (using **N** for next, or **P** for previous), and check the LES State field.

If the LES State field value is not **Enabled**, make sure that the LES is enabled on the setup dialog box and that the LES settings correspond to your switch and ELAN.

Following is general LES statistics information:

Field/Field Group	Description
LES Unit	LES number.
LES	LES information: <ul style="list-style-type: none"> • LES state • Name of the ELAN served by the LES • Type of ELAN served by the LES • MTU size of the ELAN served by the LES • ATM Network Prefix and ESI/Selector address of the LES

Field/Field Group	Description
BUS ATM Address	ATM Network Prefix and ESI/Selector address of the BUS on which the LES's host adapter is installed

LES Client Service Table Statistics

To display client service traffic statistics for an LES enabled on an adapter:

1. On the main CellView dialog box, select the adapter and select **Statistics** on the pop-up menu. Then select the **LES** tab.
2. On the LES dialog box, select the LES (using **N** for next, or **P** for previous).
3. Select the **LES (CST)** tab.

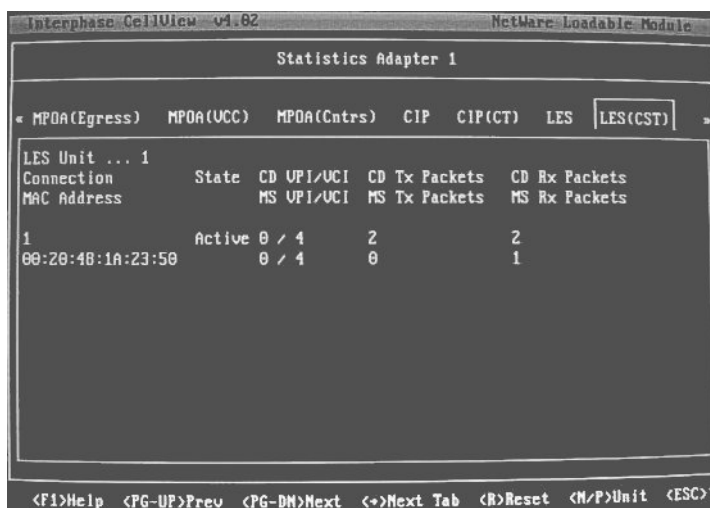

Figure 10-23. LES (CST) Statistics

The CD Tx Packets, CD Rx Packets, MS Tx Packets, and MS Rx Packets fields should indicate traffic. If the statistics indicate a lack of traffic, make sure that the settings on the setup dialog box for the LES correspond to your switch and ELAN.

Following is detailed LES Client Service Table statistics information:

Field/Field Group	Description
LES Unit	LES number.

Field/Field Group	Description
Client Service Table	<p>Information about each connection between the LES and a LEC:</p> <ul style="list-style-type: none"> • Connection number • Connection state • Virtual Path Identifier and Virtual Circuit Identifier of the Control Direct (CD) VCC used to exchange control information with the LEC • Number of Control Direct packets transmitted to the LEC • Number of Control Direct packets received from the LEC • MAC address of the connected client • Virtual Path Identifier and Virtual Circuit Identifier of the Multicast Send (MS) VCC used to exchange information with the LEC • Number of Multicast Send packets transmitted to the LEC • Number of Multicast Send packets received from the LEC

LECS Statistics

To display statistics for an LECS enabled on the adapter, on the main CellView dialog box, select the adapter and select **Statistics** on the pop-up menu. Then select the **LECS** tab to display the LECS Statistics dialog box.

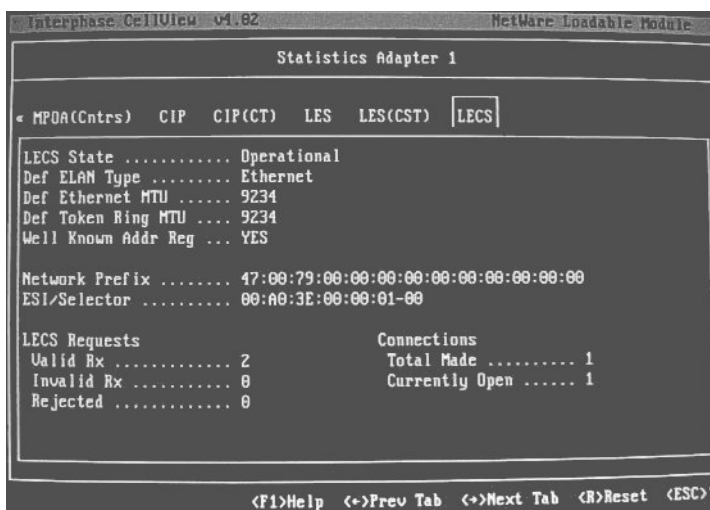

Figure 10-24. LECS Statistics

Check the following indicators:

- The LECS State field should read **Enabled**.
- The LECS Requests and Connections fields should indicate that the LECS is processing requests and making connections.

If the LECS state is not enabled, and statistics indicate a lack of activity, make sure that the settings on the LECS setup dialog box correspond to your switch and ELAN.

Following is detailed LECS statistics information:

Field/Field Group	Description
LECS	LECS information: <ul style="list-style-type: none"> • LECS state • Default ELAN type the LECS assigns to clients • Default MTU size the LECS assigns to Ethernet clients • Default MTU size the LECS assigns to Token Ring clients • Well Know Addr Reg—indication of whether the LECS is registered with the switch to use the Well Known ATM address • ATM Network Prefix and ESI/Selector address of the LECS
LECS Requests	Number of valid and invalid connection requests the LECS receives from clients. Also, number of LEC requests rejected by the LECS.
Connections	Total number of connections made between the LECS and LECs. Also, number of LEC connections that have been requested but not completed.

Overview

This chapter provides possible solutions for common problems you might encounter while installing and operating the ATM adapter. Before proceeding with the troubleshooting, make sure you have carefully followed the steps for installing the hardware and the software, and have rebooted the system. Also, check the systems log for your operating system to see what kind of errors, if any, are being recorded. This may provide some insight into the problem.

If the information in this chapter does not resolve the problem, contact Interphase Customer Support at one of the locations listed in the front of this users guide.

Interpreting LEDs

The adapter has two LEDs:

- Green Link LED
- Yellow Status LED

The following table provides information about LED states:

LED	State	Indication
Link	Off	The adapter is not receiving a signal from a switch or remote system.
Link	Solid Green	The adapter is receiving a signal from a switch or remote system.
Status	Off	The adapter does not have power.
Status	Solid Yellow	The adapter has power.
Status	Flashing Yellow	The driver is loaded and the interface has been configured.

The green Link LED indicates the condition of the physical link between the adapter and the ATM switch. When the Link LED is lit, light or electrical current is flowing between the two sets of hardware; however, data may or may not be flowing through the cable.

The yellow Status LED serves two functions. When the machine is turned on, the LED glows a solid yellow to indicate that the adapter has power. Then it begins flashing to indicate that the software driver is loaded and an adapter interface has been configured.

Problems and Possible Solutions

This section presents possible solutions for the following types of adapter problems:

- Link and status problems
- Boot problems
- Network problems

Link and Status Problems

Problems indicated by the Link and Status LEDs might be related to hardware failure, inadequate power access, or improper driver installation.

Problem	Possible Solution
<p>The Link LED is not lit.</p>	<p>A failure in the hardware is preventing the adapter from completing a physical link with the switch.</p> <ol style="list-style-type: none"> 1. Check the switch. It must be up and running for the adapter to make a link. 2. Unplug and reinstall the connectors. 3. Try a known good cable. 4. Check the transmit and receive wiring to see if they are reversed. See Connecting to the Network on page 11. 5. If a known good cable is installed, try another adapter in the PMC expansion slot. <p>If the green LED does not illuminate, the problem is probably at the switch. Confirm this by configuring the cable to another port on the switch.</p>
<p>The Status LED is not lit.</p>	<p>Power is not getting to the adapter.</p> <ol style="list-style-type: none"> 1. Do a power reset of the computer by turning the power off and then on again. 2. Make sure the adapter is seated correctly in the PMC expansion slot. Check for a bent pin or crack in the connector. 3. Try another PMC expansion slot. 4. Try another adapter known to operate correctly.

Problem	Possible Solution
The Status LED is lit, but is not flashing.	<p>The driver is not installed correctly, or the network interface is not configured.</p> <ol style="list-style-type: none"> 1. If the driver is not installed, install it. 2. If the driver is installed, check your system's error message log to see if any errors pertaining to the ATM driver were recorded during the boot process. This might provide some insight into the problem. 3. Reinstall the driver if it is not installed correctly. 4. If the driver is installed correctly, you might need to configure the network protocols, as described in the driver installation instructions for your system.

Boot Problems

Boot problems are usually hardware related. For example, the adapter is located in the wrong slot, or the bus address is incorrect or in conflict with another device. If the machine worked properly before the adapter was installed, then the problem is probably with the adapter or with hardware that was removed and replaced during adapter installation.

Problem	Possible Solution
The computer does not boot up.	<ol style="list-style-type: none"> 1. Check to see if the adapter is properly seated in the expansion slot. Reseat the adapter and restart the machine. 2. Try a different expansion slot. 3. Remove the adapter and reboot the system. 4. If the system boots up and returns to a normal state, the adapter is probably defective. Confirm this by installing an adapter known to work correctly. 5. If a defective adapter is not the problem, try reinstalling the configuration utility (if applicable). 6. Try changing the interrupt setting or removing other hardware on the bus until the conflict is located. <p>Change one setting at a time and record the settings to keep track of your changes.</p>

Problem	Possible Solution
<p>The host adapter is not found.</p>	<p>The system cannot find or does not recognize the adapter. The PCI system in your computer is supposed to automatically configure the bus address locations; therefore, an address conflict is probably not the problem. If the driver is installed correctly, a driver message should appear in the message log when the computer boots up.</p> <ol style="list-style-type: none"> 1. If this is your first boot process since installing the adapter, the adapter hardware interrupt or configuration registers might not match what the system expects. Instead of rebooting the system, turn the power off and then on again to reset all components to an initial state. 2. The adapter might be installed in the wrong slot. Make sure the adapter is in the slot for which the driver is configured. See your system manual(s) for the location of the proper expansion slots. 3. Make sure the adapter is seated correctly in the slot. 4. Try another expansion slot, if available. 5. Try another adapter known to operate correctly. 6. Check connection of the network cable to the adapter card. Verify the cable is properly connected at both ends. Ping the failed system from another host on the network. 7. Check the error message log on your system to see if any errors pertaining to the ATM adapter or driver were recorded while booting. This might provide some insight into the problem.

Network Problems

The procedures in this section assume the following have occurred:

- The host workstation is up and running.
- The driver is loaded. (The yellow Status LED is flashing.)
- The adapter has formed a physical link with the switch. (The green Link LED is lit.)

If this is not the case, see the procedures in [Link and Status Problems on page 168](#) and [Boot Problems on page 169](#).

In all cases of network problems, check the error message log on your system to see if the clients are being rejected by the LECS or the LES. For the client to have any form of communication with a server, the following must have occurred:

- The switch must be configured correctly.
- signaling must be up and running.

- The adapter must be assigned a network prefix.
- At least one client must be enabled.
- At least one LES must be present on the network.

The GUI version of the CellView utility provides debugging options as a tool for troubleshooting adapter and network-related problems. With debugging enabled, various modules log messages to assist in isolating the problem. (Be sure to disable the options when debugging is complete so that debugging output does not continue to output to the screen.) See [Producing Debugging Messages on page 104](#) for additional information about CellView debugging options.

Problem	Possible Solution
The adapter cannot communicate with other hosts on the network.	<ol style="list-style-type: none">1. Make sure the network cable is correctly installed.2. Try to ping other end stations on the network from your host computer.3. Try to ping the host computer from another end station on the network.

Problem	Possible Solution
The driver loads at boot, but network clients are not connecting (GUI systems).	<ol style="list-style-type: none"><li data-bbox="609 304 1161 787">1. Start CellView; then check the signaling state, as follows:<ol style="list-style-type: none"><li data-bbox="641 378 1161 472">a. From the CellView dialog box, select the adapter and click Stats; then check indicators on the signaling dialog box.<li data-bbox="641 483 1161 609">b. If the graphical LEDs for signaling are green, then signaling is up and running. See the problem, <i>signaling is running, but network clients are not connecting</i> on page 174.<li data-bbox="641 619 1161 714">c. If the graphical LEDs are red, exit to the main dialog box and click Setup; then select the signaling tab.<li data-bbox="641 724 1161 787">d. Make sure the setting in the UNI Revision field corresponds to the UNI setting of your switch.<li data-bbox="609 798 1161 1008">2. Use CellView to check the hardware status.<ol style="list-style-type: none"><li data-bbox="641 840 1161 903">a. From the CellView dialog box, click Stats; then select the AAL5 tab.<li data-bbox="641 913 1161 1008">b. If any of the graphical LEDs in the SONET box is red, a failure occurred somewhere in the cable or connectors.<li data-bbox="609 1018 1161 1375">3. Use CellView to track communications between the adapter and the ATM switch.<ol style="list-style-type: none"><li data-bbox="641 1092 1161 1155">a. From the CellView dialog box, click Global; then select the Debugging tab.<li data-bbox="641 1165 1161 1375">b. Enable the signaling and ILMI options.<p data-bbox="641 1218 1161 1375">CellView tracks communications between the adapter and signaling in the switch, as well as the protocols used to monitor all other traffic. Check the error message log on your system for error messages about these communications.</p> <p data-bbox="609 1375 1161 1472">When network debugging is complete, disable CellView Debugging options to stop further debugging output to the screen.</p>

Problem	Possible Solution
The driver loads at boot, but network clients are not connecting (NetWare systems).	<ol style="list-style-type: none"> 1. Start CellView; then check the signaling state, as follows: <ol style="list-style-type: none"> a. From the CellView dialog box, select the adapter. Then select Statistics, and check the signaling State fields on the signaling dialog box. b. If ILMI and QSAAL read up and signaling reads init, then signaling is up and running. See the problem, <i>signaling is running, but network clients are not connecting</i> on page 174. c. If signaling State fields indicate that signaling is not up, open the boot configuration file (as described in <i>Editing the Boot Configuration File</i> on page 116). d. Make sure the UNI parameter value in each client's LOAD command corresponds to the UNI setting of your switch. 2. Use CellView to check the hardware status. <ol style="list-style-type: none"> a. From the CellView dialog box, select the adapter. Then select Statistics, and select the AAL5 tab. b. On the AAL5 dialog box, if any of the SONET fields do not read as ok, a failure occurred somewhere in the cable or connectors.

Problem	Possible Solution
<p>signaling is running, but network clients are not connecting (GUI systems).</p>	<p>Start CellView and check the signaling setup for the adapter, as follows:</p> <ol style="list-style-type: none"> 1. From the CellView dialog box, select the adapter and click Stats. 2. On the signaling statistics dialog box, check for a 13-byte address in the Network Prefix field. If the address is not present, the switch is configured incorrectly or the signaling setup for the adapter is in error. 3. Make sure that signaling settings correspond to the capabilities of your LAN Emulation services. <ol style="list-style-type: none"> a. Exit to the CellView dialog box, select the adapter, and click Setup; then select the signaling tab. b. Make sure the settings for Enable Address Registration, ILMI Port Change Detection, and Register Nonstandard Prefixes are appropriate. c. If automatic address assignment is not supported by the switch, disable ILMI Address Registration, and enter the adapter's 13-byte Network Prefix in the Network Prefix field. <p>See Setting Up UNI signaling on page 62 for additional information.</p>
<p>signaling is running, but network clients are not connecting (NetWare systems).</p>	<p>Start CellView and check the signaling setup for the adapter, as follows:</p> <ol style="list-style-type: none"> 1. From the CellView dialog box, select the adapter. Then select Statistics. 2. Check the signaling statistics dialog box for a 13-byte address in the Network Prefix field. If the address is not present, the switch is configured incorrectly or the signaling setup for the adapter is in error.

Problem	Possible Solution
signaling and Address Registration are working, but network clients are not connecting (GUI and NetWare Systems).	<p>Start CellView and check settings for each client:</p> <ol style="list-style-type: none">1. Access the LEC dialog box, as follows:<ul style="list-style-type: none">– For GUI systems, from the CellView dialog box, select the adapter and click Setup; then select the LEC tab and the appropriate LEC# tab.– For NetWare systems, from the CellView dialog box, select the adapter. Then select Setup, select the LEC tab, and move to the appropriate LEC number.2. Make sure the LECS/LES parameters are specified correctly. These settings must correspond to the capabilities of your switch.3. The ELAN MTU size must be equal to or greater than the setting for an LES. For example, if only one LES is enabled with an MTU of 9K, and the client attempts to join with an MTU of 1516, the client will be rejected. <p>Make sure the other settings in the dialog box correspond to at least one of the enabled LESs.</p>

Problem	Possible Solution
A network application no longer works (GUI and NetWare systems).	<p>If the application worked before adapter installation, a hardware conflict probably occurred. Some programs that access the hardware can cause a conflict at some point. This typically happens with hardware such as printers and modems.</p> <ol style="list-style-type: none">1. Check your system's PCI configuration.2. Check the Application Program Interface (API) functions.<ul style="list-style-type: none">– For GUI systems, start CellView. Then from the CellView dialog box, select Global. Select the Debugging tab, and enable the API option. CellView tracks the lower-level functions of the API. These are the routines used by application software to manage or obtain system resources. Check your system's message log. If no messages are being recorded, reboot the machine, run the application again, and check the log again. When network debugging is complete, disable CellView Debugging options to stop further debugging output from printing to the screen.– For NetWare systems, press CTRL + ESC to display the system console. Then select ASIG_Process and press Enter to view API functions.

Specifications

Item	Specification
Memory	128K, 512K, or 1M buffer 1K serial EEPROM Optional Expansion ROM 128K Control SRAM
Host Bus Interface	CompactPCI Bus Revision 1.0 32-bit 0 wait state Master 132 Mbyte/s burst DMA rate 32-bit Slave 128-byte burst 256-byte FIFOs
Network Interface	155 Mbps SONET OC-3c fiber 155 Mbps SDH STM-1 fiber 155 Mbps SONET UTP
Standards Compliance:	
IEEE:	IEEE 1496
ATM Layer:	CCITT I.361, ANSI T1S1/92-002R3
ATM Adaptation Layer:	AAL 5
Signaling:	UNI 3.0/3.1/4.0
PVC Encapsulation	Full RFC 1483
SVC Encapsulation:	ATM Forum LAN Emulation (Version 1 and Version 2), IETF RFC 1577 Classical IP over ATM, and support for ATM Forum MPOA and IETF RFC 2225 Classical IP over ATM
Operating Power	1.11A @ 5.25V DC
Interrupts	Interrupt Pin: INTA#
Diagnostics	LEDs: Green "Live incoming link" Yellow "Status"
PCI Slave	Memory and Configuration cycles Write posting

Item	Specification
PCI Master	Zero wait states Memory cycles only Burst size selections: 64, 32, 16, 8, 4 (Tx) 64, 48, 32, 16, 8, 4 (Rx, On-board) 48, 32, 16, 8, 4 (Rx, CELL-FIFO) Memory Read Line support Memory Read Multiple support Memory Write and Invalidate
Mechanical	Length: 160.00 mm; Height: 100.00 mm
Operating Environment:	
Temperature	32–131° F/0–55° C
Relative Humidity	10–95% noncondensing
Altitude	0–15,000 feet
Storage Environment:	
Temperature	-4–185° F/-20–85° C
Relative Humidity	10–95% noncondensing
Altitude	0–50,000 feet
Network Connections:	
SC Duplex (155 Mbps)	Single Mode Fiber (8.5/125) Maximum cable length: 50,000 ft/15 km Minimum cable length: 9.8 ft/3 m
SC Duplex (155 Mbps)	Multimode Fiber (62.5/125) Maximum cable length: 1.2 miles/2 km Minimum cable length: 9.8 ft/3 m
RJ-45 (155 Mbps)	Category 5 UTP Copper Maximum cable length: 328 ft/100 m

Straight-Through Cable

To connect an adapter to an ATM switch, use a straight-through cable.

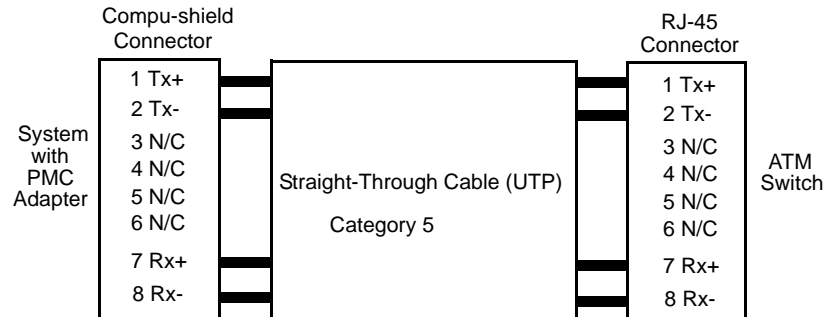

Crossover Cable

To connect two end stations back-to-back, use a crossover cable.



CAUTION

For straight-through and crossover cabling to meet EMI specifications, the unused pairs must be connected at both ends of the cable to the Compu-shield and/or RJ-45 connectors.

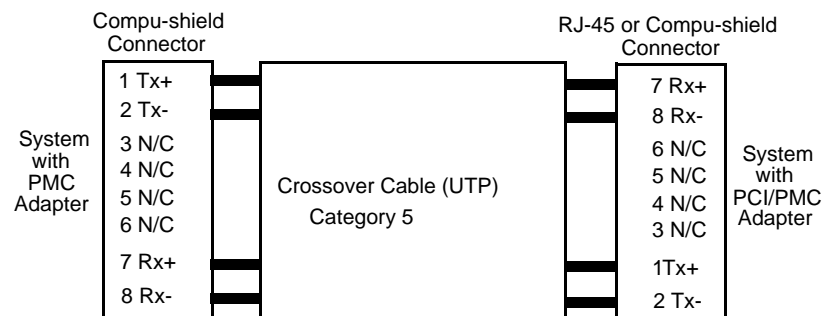

FCC

6575 ATM Adapter

FCC Part 15 Regulatory Compliance

This equipment has been tested and found to comply with the limits for a Class A digital device, pursuant to part 15 of the FCC Rules. These limits are designed to provide reasonable protection against harmful interference when the equipment is operated in a commercial environment. This equipment generates, uses, and can radiate radio frequency energy and, if not installed and used in accordance with the instruction manual, may cause harmful interference to radio communications. Operation of this equipment in a residential area is likely to cause harmful interference in which case the user will be required to correct the interference at his own expense.

This equipment complies with Part 15 of the FCC Rules. Operation is subject to the following two conditions:

- (1) This equipment may not cause harmful interference, and
- (2) This equipment must accept any interference received, including interference that may cause undesired operation.

Canadian

Tested to Comply with Canadian Standards

This Class A digital apparatus complies with Canadian ICES-003.

Cet appareil numérique de la classe A est conforme à la norme NMB-003 du Canada.

European

Regulatory Information for Europe

This equipment displays the CE mark to show that it has been found to be in full compliance with the requirements of the EMC and Low Voltage Directives (89/336/EEC and 72/23/EEC, as amended by Directive 93/68/EEC).



WARNING

This is a class A product. In a domestic environment this product may cause radio interference in which case the user may be required to take adequate measures.

EN60950–IEC950 Safety Standard

This equipment complies with the EN60950–IEC950 safety standard.

Fiber Products' Compliance, LASER

6575-008, -009, -011 Single Mode CompactPCI ATM Adapters

These Interphase fiber products contain a Class 1 laser device. They comply with IEC825-1, IEC825-2, and FDA 21 CFR 1040.10 and 1040.11. These products must be operated under recommended operating conditions.

Ce produit Interphase comporte une interface pour fibre optique utilisant un dispositif laser de classe 1. Il est conforme aux normes CEI 825-1 et 825-2, et FDA 21 CFR 1040,10 et 1040,11. Cet appareil doit être utilisé conformément aux conditions de fonctionnement recommandées.

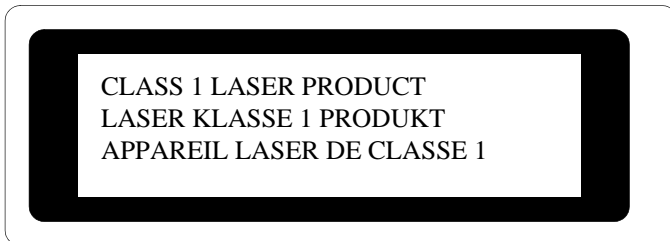

Usage Restrictions

The optical ports of these devices shall be terminated with an optical connector or with a dust plug.

Restrictions d'utilisation

Les branchements optiques de cet appareil doivent toujours être raccordés à un connecteur optique ou porter un bouchon de protection.

Fiber Products' Compliance, LED

6575-002, -003, -010 Multi Mode CompactPCI ATM Adapters

These Interphase fiber products use an LED and comply with IEC825-1, IEC825-2, and FDA 21 CFR 1040.10 and 1040.11.

AAL ♦ **ATM Adaptation Layer** Service-dependent sublayer of the data link layer. The AAL accepts data from different applications and presents it to the *ATM* layer in the form of 48-byte ATM payload segments. AALs consist of two sublayers: *CS* and *SAR*. AALs differ on the basis of the source-destination timing used, whether they use *CBR* or *VBR*, and whether they are used for connection-oriented or connectionless mode data transfer. At present, the four types of AAL recommended by the ITU-T are *AAL1*, *AAL2*, *AAL3/4*, and *AAL5*.

AAL1 ♦ **ATM Adaptation Layer 1** One of four *AALs* recommended by the ITU-T. AAL1 is used for connection-oriented, delay-sensitive services requiring constant bit rates, such as uncompressed video and other isochronous traffic.

AAL2 ♦ **ATM Adaptation Layer 2** One of four AALs recommended by the ITU-T. AAL2 is used for connection-oriented services that support a variable bit rate, such as some isochronous video and voice traffic.

AAL3/4 ♦ **ATM Adaptation Layer 3/4** One of four AALs (merged from two initially distinct adaptation layers) recommended by the ITU-T. AAL3/4 supports both connectionless and connection-oriented links, but is primarily used for the transmission of *SMDS* packets over *ATM* networks.

AAL5 ♦ **ATM Adaptation Layer 5** One of four AALs recommended by the ITU-T. AAL5 supports connection-oriented *VBR* services and is used predominantly for the transfer of classical *IP* over *ATM* and *LANE* traffic. AAL5 uses *SEAL* and is the least complex of the current AAL recommendations. It offers low bandwidth overhead and simpler processing requirements in exchange for reduced bandwidth capacity and error-recovery capability.

ABR ♦ **Available Bit Rate** *QoS* class defined by the ATM Forum for ATM networks. ABR is used for connections that do not require timing relationships between source and destination. ABR provides no guarantees in terms of cell loss or delay, providing only best-effort service. Traffic sources adjust their transmission rate in response to information they receive describing the status of the network and its capability to successfully deliver data. Compare with *CBR*, *UBR*, and *VBR*.

AIN ♦ **Advanced Intelligent Network** In *SS7*, an expanded set of network services made available to the user, and under user control, that requires improvement in network switch architecture, signaling capabilities, and peripherals.

AMI ♦ **Alternate Mark Inversion** Line-code type used on *TI* and *E1* circuits. In AMI, zeros are represented by 01 during each bit cell, and ones are represented by 11 or 00, alternately, during each bit cell. AMI requires that the sending device maintain ones density. Ones density is not maintained independently of the data stream. Sometimes called binary coded alternate mark inversion.

API ♦ **Application Programming Interface** (1) The interface to a library of language-specific subroutines (such as a graphics library) that implement higher-level functions. (2) A set of calling conventions defining how a service is invoked through a software package.

Apple Talk ♦ Series of communications protocols designed by Apple Computer consisting of two phases. Phase 1, the earlier version, supports a single physical network that can have only one network number and be in one zone. Phase 2, supports multiple logical networks on a single physical network and allows networks to be in more than one zone.

ASCII ♦ **American Standard Code for Information Interchange** The standard binary encoding of alphabetical characters, numbers, and other keyboard symbols.

ATM ♦ **Asynchronous Transfer Mode** International standard for cell relay in which multiple service types (such as voice, video, or data) are conveyed in fixed-length (53-byte) cells. Fixed-length cells allow cell processing to occur in hardware, thereby reducing transit delays. ATM is designed to take advantage of high-speed transmission media such as *E3*, *SONET*, and *T3*.

B8ZS ♦ **Binary 8-Zero Substitution** Line-code type, used on *TI* and *E1* circuits, in which a special code is substituted whenever 8 consecutive zeros are sent over the link. This code is then interpreted at the remote end of the connection. This technique guarantees ones density independent of the data stream. Sometimes called bipolar 8-zero substitution.

B Channel ♦ **Bearer Channel** In ISDN, a full-duplex, 64-kbps channel used to send user data.

BIOS ♦ **Basic Input/Output System** The built-in program that controls the basic functions of communications between the processor and the Input/Output (I/O) devices of a computer.

BISDN ♦ **Broadband ISDN** *ITU-T* communication standards designed to handle high-bandwidth applications such as video. BISDN currently uses *ATM* technology over *SONET*-based transmission circuits to provide data rates from 155 to 622 Mbps and beyond.

bootROM ♦ **boot Read-Only Memory** Chip mounted on the printed circuit board used to provide executable boot instructions to a computer device.

BRI ♦ **Basic Rate Interface** *ISDN* interface composed of two *B Channels* and one *D Channel* for circuit-switched communication of voice, video, and data.

BSP ♦ **Board Support Package** A board support package consists of documentation and software used to configure and install a specific operating system on a specific product.

BUS ♦ **Broadcast and Unknown Server** Multicast server used in *ELANs* that is used to flood traffic addressed to an unknown destination and to forward multicast and broadcast traffic to the appropriate clients.

CAM ♦ **Content Addressable Memory** Memory that is accessed based on its contents, not on its memory address.

CBR ♦ **Constant Bit Rate** *QoS* class defined by the *ATM* Forum for ATM networks. CBR is used for connections that depend on precise clocking to ensure undistorted delivery.

CCS ♦ **Common Channel Signaling** Signaling system used in telephone networks that separates signaling information from user data. A specified channel is exclusively designated to carry signaling information for all other channels in the system.

COM ♦ **Communication or Communications**

CompactPCI ♦ CompactPCI is an adaptation of the Peripheral Component Interconnect (*PCI*) Specification for industrial and/or embedded applications requiring a more robust mechanical form factor than desktop PCI. CompactPCI uses industry standard mechanical components and high performance connector technologies to provide an optimized system intended for rugged applications. CompactPCI provides a system that is electrically compatible with the PCI Specification, allowing low cost PCI components to be utilized in a mechanical form factor suited for rugged environments. CompactPCI is an open specification supported by the PICMG (PCI Industrial Computer Manufacturers Group), which is a consortium of companies involved in utilizing PCI for embedded applications.

CPCS ♦ **Common Part Convergence Sublayer** An abstract *ATM* protocol *API* defined by the *ATM* Forum. It forms the boundary interface between the purely software implemented higher layer ATM protocols and the segmentation and reassembly process controlled by hardware.

CPM ♦ **Communication Processing Module**

CRC4 ♦ **Cyclic Redundancy Check**. Error-checking technique in which the frame recipient calculates a remainder by dividing frame contents by a prime binary divisor and compares the calculated remainder to a value stored in the frame by the sending node.

CS ♦ **Convergence Sublayer** One of the two sublayers of the *AAL CPCS*, which is responsible for padding and error checking. *PDU*s passed from the *SSCS* are appended with an 8-byte trailer (for error checking and other control information) and padded, if necessary, so that the length of the resulting PDU is divisible by 48. These PDUs are then passed to the *SAR* sublayer of the CPCS for further processing.

CSU ♦ **Channel Service Unit** A component that terminates a digital circuit, such as *TI*. A CSU assures compliance to FCC regulations and performs some line-conditioning functions.

D Channel ♦ **Data Channel** Full-duplex, 16-kbps (*BRI*) or 64-kbps (*PRI*) *ISDN* channel.

DCE ♦ 1. **Data Communications Equipment** (EIA expansion). 2. **Data Circuit-terminating Equipment** (ITU-T expansion). Devices and connections of a communications network that comprise the network end of the user-to-network interface. The DCE provides a physical connection to the network, forwards traffic, and provides a clocking signal used to synchronize data transmission between DCE and DTE devices. Modems and interface cards are examples of DCE.

DLCI ♦ **Data-Link Connection Identifier** Value that specifies a *PVC* or *SVC* in a *Frame Relay* network. In the basic Frame Relay specification, DLCIs are locally significant (connected devices might use different values to specify the same connection). In the *LMI* extended specification, DLCIs are globally significant (DLCIs specify individual end devices).

DMA ♦ **Direct Memory Access** The transfer of data directly into memory without supervision of the processor. The data is passed on the bus directly between the memory and another device.

DPRAM ♦ **Dual Port Random Access Memory**

DS1 ♦ **Digital Signal level 1** Framing specification used in transmitting digital signals at 1.544-Mbps on a *TI* facility (in the United States) or at 2.108-Mbps on an *E1* facility (in Europe).

DS3 ♦ **Digital Signal level 3** Framing specification used for transmitting digital signals at 44.736 Mbps on a *T3* facility.

DSX1 ♦ Cross-connection point for *DS1* signals.

DTE ♦ **Data Terminal Equipment** Device at the user end of a user-network interface that serves as a data source, destination, or both. DTE connects to a data network through a *DCE* device (for example, a modem) and typically uses clocking signals generated by the DCE. DTE includes such devices as computers, protocol translators, and multiplexers.

E1 ♦ Wide-area digital transmission scheme used predominantly in Europe that carries data at a rate of 2.048 Mbps. E1 lines can be leased for private use from common carriers.

E3 ♦ Wide-area digital transmission scheme used predominantly in Europe that carries data at a rate of 34.368 Mbps. E3 lines can be leased for private use from common carriers.

EEPROM ♦ **Electrically Erasable Programmable Read-Only Memory** A nonvolatile *PROM* that can be written as well as read form. Usually used to hold information about the current system configuration, alternate boot paths, etc.

ELAN ♦ **Emulated LAN** *ATM* network in which an Ethernet or Token Ring *LAN* is emulated using a client-server model. ELANs are composed of an *LEC*, an *LES*, a *BUS*, and an *LECS*. Multiple ELANs can exist simultaneously on a single *ATM* network. ELANs are defined by the *LANE* specification.

END ♦ **Enhanced Network Driver**

EPLD ♦ **Electrically Programmable Logic Device**

ES ♦ **End System** Generally, an end-user device on a network.

ESF ♦ **Extended Superframe Format** Framing type used on *TI* circuits that consists of 24 frames of 192 bits each, with the 193rd bit providing timing and other functions.

Ethernet ♦ Baseband *LAN* specification invented by Xerox Corporation and developed jointly by Xerox, Intel, and Digital Equipment Corporation.

FCC ♦ **Federal Communications Commission** The Government agency responsible for regulating telecommunications in the United States.

FCC ♦ **Fast serial Communication Controllers** Used to control the fast Ethernet port.

FDDI ♦ **Fiber Distributed Data Interface** *LAN* standard, defined by ANSI X3T9.5, specifying a 100-Mbps token-passing network using fiber-optic cable, with transmission distances of up to 2 km. FDDI uses a dual-ring architecture to provide redundancy.

Flash ♦ Nonvolatile storage that can be electrically erased and reprogrammed so that software images can be stored, booted, and rewritten as necessary.

Frame Relay ♦ Industry-standard, switched data link layer protocol that handles multiple virtual circuits using *HDLC* encapsulation between connected devices. Frame Relay is more efficient than *X.25*, the protocol for which it is generally considered a replacement.

FTP ♦ **File Transfer Protocol** Application protocol, part of the *TCP/IP* protocol stack, used for transferring files between network nodes.

GB ♦ **GigaBytes** 10^9 bytes per second.

Gbps ♦ **Gigabits per second** 10^9 bits per second.

HDLC ♦ **High-Level Data Link Control** Bit-oriented synchronous data link layer protocol developed by *ISO*. Derived from *SDLC*, *HDLC* specifies a data encapsulation method on synchronous serial links using frame characters and checksums.

IMA ♦ **Inverse Multiplexing over ATM** Standard protocol defined by the ATM Forum in 1997.

IMMR ♦ **Internal Memory Map Register**

IP ♦ **Internet Protocol** Network layer protocol in the *TCP/IP* stack offering a connectionless internet-network service. IP provides features for addressing, type-of-service specification, fragmentation and reassembly, and security.

IPv6 ♦ **IP version 6** Replacement for the current version of IP (version 4). IPv6 includes support for flow ID in the packet header, which can be used to identify flows. Formerly called IPng (next generation).

IPX ♦ **Internetwork Packet Exchange** NetWare network layer (Layer 3) protocol used for transferring data from servers to workstations. IPX is similar to *IP* and *XNS*.

ISDN ♦ **Integrated Services Digital Network** Communication protocol, offered by telephone companies, that permits telephone networks to carry data, voice, and other source traffic.

ISO ♦ **International Organization for Standardization** International organization that is responsible for a wide range of standards, including those relevant to networking. ISO developed the *OSI* reference model, a popular networking reference model.

ITU-T ♦ **International Telecommunication Union Telecommunication Standardization Sector** International body that develops worldwide standards for telecommunications technologies. The ITU-T carries out the functions of the former CCITT.

J1 ♦ Japanese transmission standard

LAN ♦ **Local-Area Network** High-speed, low-error data network covering a relatively small geographic area (up to a few thousand meters). LANs connect workstations, peripherals, terminals, and other devices in a single building or other geographically limited area. LAN standards specify cabling and signaling at the physical and data link layers of the *OSI* model. *Ethernet*, *FDDI*, and *Token Ring* are widely used LAN technologies.

LANE ♦ **LAN Emulation** Technology that allows an *ATM* network to function as a *LAN* backbone. The *ATM* network must provide multicast and broadcast support, address mapping (*MAC Address*-to-*ATM*), *SVC* management, and a usable packet format. LANE also defines *Ethernet* and *Token Ring ELANs*.

LAPB ♦ **Link Access Procedure, Balanced**. Data link layer protocol in the *X.25* protocol stack. LAPB is a bit-oriented protocol derived from *HDLC*.

LEC ♦ **LAN Emulation Client** Entity in an end system that performs data forwarding, address resolution, and other control functions for a single *ES* within a single *ELAN*. An LEC also provides a standard *LAN* service interface to any higher-layer entity that interfaces to the LEC. Each LEC is identified by a unique *ATM* address, and is associated with one or more *MAC Addresses* reachable through that *ATM* address.

LECS ♦ **LAN Emulation Configuration Server** Entity that assigns individual *LANE* clients to particular *ELANs* by directing them to the *LES* that corresponds to the *ELAN*. There is logically one LECS per administrative domain, and this serves all *ELANs* within that domain.

LED ♦ **Light Emitting Diode** A semiconductor device used to provide visual indications, used in place of an incandescent light. Also a semiconductor device used to transmit light into a fiber.

LES ♦ **LAN Emulation Server** Entity that implements the control function for a particular *ELAN*. There is only one logical LES per *ELAN*, and it is identified by a unique *ATM* address.

LMI ♦ **Local Management Interface** Set of enhancements to the basic *Frame Relay* specification. LMI includes support for a keepalive mechanism, which verifies that data is flowing; a multicast mechanism, which provides the network server with its local *DLCI* and the multicast *DLCI*; global addressing, which gives *DLCIs* global rather than local significance in *Frame Relay* networks; and a status mechanism, which provides an on-going status report on the *DLCIs* known to the switch. Known as LMT in ANSI terminology.

MAC Address ♦ Standardized data link layer address that is required for every port or device that connects to a *LAN*. Other devices in the network use these addresses to locate specific ports in the network and to create and update routing tables and data structures. *MAC* addresses are 6 bytes long and are controlled by the IEEE. Also known as a hardware address, *MAC*-layer address, and physical address.

MCC ♦ **Multichannel Communication Controller**

MiniDIN ♦ Miniature multi-pin connector.

MPOA ♦ **Multiprotocol over ATM** *ATM* Forum standardization effort specifying how existing and future network-layer protocols such as *IP*, *IPv6*, *Apple Talk*, and *IPX* run over an *ATM* network with directly attached hosts, routers, and multilayer *LAN* switches.

MUX ♦ **Multiplexer** Combines multiple signals for transmission over a single line. The signals are demultiplexed, or separated, at the receiving end

NT1 ♦ **Network Termination 1** A device that provides the interface between customer premises equipment and central office switching equipment.

NVRAM ♦ **Nonvolatile RAM** *RAM* that retains its contents when a unit is powered off.

OC3 ♦ **Optical Carrier 3** Physical protocol defined for *SONET* optical signal transmissions. OC3 signal levels put *STS* frames onto multimode fiber-optic line at 155.52 Mbps.

OSI ♦ **Open System Interconnection** International standardization program created by *ISO* and *ITU-T* to develop standards for data networking that facilitate multivendor equipment interoperability.

PARC ♦ **Palo Alto Research Center** Research and development center operated by XEROX. A number of widely-used technologies were originally conceived at PARC, including the first personal computers and *LANs*.

PCI ♦ **Peripheral Component Interconnect** A high-performance multiplexed address and data bus. Supporting 32-bit with optional 64-bit data transfers, the PCI bus is intended to be an interconnect between peripheral controllers, peripheral add-in boards, and processor/memory systems. The PCI bus operates at up to 33 MHz, providing burst transfer rates up to 132 MBps 32 bits wide, or up to 264 MBps 64 bits wide.

PDN ♦ **Public Data Network** Network operated either by a government (as in Europe) or by a private concern to provide computer communications to the public, usually for a fee. PDNs enable small organizations to create a *WAN* without all the equipment costs of long-distance circuits.

PDU ♦ **Protocol Data Unit** A message of a given protocol comprising payload and protocol-specific control information, typically contained in a header.

PLP ♦ **Packet Level Protocol** Network layer protocol in the *X.25* protocol stack. Sometimes called X.25 Level 3 and X.25 Protocol.

PMC ♦ **PCI Mezzanine Card** *PCI* “daughter” card designed to mount on a “mother card”.

POST ♦ **Power-On-Self-Test** Test that automatically runs whenever the power is applied to the card.

PRI ♦ **Primary Rate Interface** *ISDN* interface to primary rate access. Primary rate access consists of a single 64-Kbps *D Channel* plus 23 (*TI*) or 30 (*E1*) *B Channels* for voice or data.

PROM ♦ **Programmable Read-Only Memory** *ROM* that can be programmed using special equipment. PROMs can be programmed only once.

PVC ♦ **Permanent Virtual Circuit or Connection** Virtual circuit that is permanently established. PVCs save bandwidth associated with circuit establishment and tear down in situations where certain virtual circuits must exist all the time. In *ATM* terminology, called a permanent virtual connection.

QoS ♦ **Quality of Service** Measure of performance for a transmission system that reflects its transmission quality and service availability.

RAM ♦ **Random-Access Memory** Volatile memory that can be read and written by a microprocessor.

RISC ♦ **Reduced Instruction Set Computing**

ROM ♦ **Read-Only Memory** Nonvolatile memory that can be read, but not written, by the microprocessor.

RTM ♦ **Rear Transition Module** A module that provides network connections from the rear of a system.

Rx ♦ **Receive or Receiver**

SAR ♦ **Segmentation And Reassembly** One of the two sublayers of the *AAL CPCS*, responsible for dividing (at the source) and reassembling (at the destination) the *PDU*s passed from the *CS*. The SAR sublayer takes the *PDU*s processed by the *CS* and, after dividing them into 48-byte pieces of payload data, passes them to the *ATM* layer for further processing.

SCC ♦ **Serial Communication Controller**

SDH ♦ **Synchronous Digital Hierarchy** European standard that defines a set of rate and format standards that are transmitted using optical signals over fiber. SDH is similar to *SONET*, with a basic SDH rate of 155.52 Mbps, designated at *STM-1*.

SDLC ♦ **Synchronous Data Link Control** *SNA* data link layer communications protocol. SDLC is a bit-oriented, full-duplex serial protocol that has spawned numerous similar protocols, including *HDLC* and *LAPB*.

SDU ♦ **Service Data Unit** A unit of interface information whose identity is preserved from one end of a layer connection to the other.

SDRAM ♦ **Synchronous Digital Random Access Memory**

SEAL ♦ **Simple And Efficient AAL** Scheme used by *AAL5* in which the *SAR* sublayer segments *CS PDU*s without adding additional fields.

-
- SIU** ♦ **Serial Interface Unit**
- SMC** ♦ **Serial Management Controller**
- SMDS** ♦ **Switched Multimegabit Data Service** High-speed, packet-switched, datagram-based [WAN](#) networking technology offered by the telephone companies.
- SNA** ♦ **Systems Network Architecture** Large, complex, feature-rich network architecture developed in the 1970s by IBM.
- SONET** ♦ **Synchronous Optical Network** High-speed (up to 2.5 Gbps) synchronous network specification developed by Bellcore and designed to run on optical fiber. [STS1](#) is the basic building block of SONET. Approved as an international standard in 1988.
- SS7** ♦ **Signaling System 7** Standard [CCS](#) system used with [BISDN](#) and [ISDN](#).
- SSCS** ♦ **Service Specific Convergence Sublayer** One of the two sublayers of any [AAL](#). SSCS, which is service dependent, offers assured data transmission. The SSCS can be null as well, in classical [IP](#) over [ATM](#) or [LAN](#) emulation implementations.
- STM-1** ♦ **Synchronous Transport Module level 1** One of a number of [SDH](#) formats that specifies the frame structure for the 155.52-Mbps lines used to carry [ATM](#) cells.
- STS** ♦ **Synchronous Transport Signal**
- STS1** ♦ **Synchronous Transport Signal level 1** Basic building block signal of [SONET](#), operating at 51.84 Mbps. Faster SONET rates are defined as STS-n, where n is a multiple of 51.84 Mbps.
- SVC** ♦ **Switched Virtual Circuit** Virtual circuit that is dynamically established on demand and is torn down when transmission is complete. SVCs are used in situations where data transmission is sporadic. Called a switched virtual connection in [ATM](#) terminology.
- T1** ♦ T1 transmits [DS1](#)-formatted data at 1.544 Mbps through the telephone-switching network, using [AMI](#) or [B8ZS](#) coding.
- T3** ♦ Digital [WAN](#) carrier facility. T3 transmits [DS3](#)-formatted data at 44.736 Mbps through the telephone switching network.
- TCP** ♦ **Transmission Control Protocol** Connection-oriented transport layer protocol that provides reliable full-duplex data transmission. TCP is part of the [TCP/IP](#) protocol stack.
- TCP/IP** ♦ **Transmission Control Protocol/Internet Protocol** Common name for the suite of protocols developed by the U.S. DoD in the 1970s to support the construction of worldwide internetworks. [TCP](#) and [IP](#) are the two best-known protocols in the suite.
- TFTP** ♦ **Trivial File Transfer Protocol** Simplified version of [FTP](#) that allows files to be transferred from one computer to another over a network.
- Token Ring** ♦ Token-passing [LAN](#) developed and supported by IBM. Token Ring runs at 4 or 16 Mbps over a ring topology. Similar to IEEE 802.5.
- TTY** ♦ **Teletypewriter** General term for an input device.
- Tx** ♦ **Transmit or Transmitter**
- UBR** ♦ **Unspecified Bit Rate** [QoS](#) class defined by the ATM Forum for ATM networks. UBR allows any amount of data up to a specified maximum to be sent across the network, but there are no guarantees in terms of cell loss rate and delay. Compare with [ABR](#), [CBR](#), and [VBR](#).
- USRBUF** ♦ A driver structure describing the use of a specific buffer containing payload data to be transferred using [ATM](#). They can be linked together to allow non-contiguous areas of memory to be sent as one unit.
- X.25** ♦ [ITU-T](#) standard that defines how connections between [DTE](#) and [DCE](#) are maintained for remote terminal access and computer communications in [PDNs](#). X.25 specifies [LAPB](#), a data link layer protocol, and [PLP](#), a network layer protocol. [Frame Relay](#) has to some degree superseded X.25.
- XNS** ♦ **Xerox Network Systems** Protocol suite originally designed by [PARC](#). Many PC networking companies, such as 3Com, Banyan, Novell, and UB Networks used or currently use a variation of XNS as their primary transport protocol.
- VBR** ♦ **Variable Bit Rate** [QoS](#) class defined by the [ATM](#) Forum for ATM networks. VBR is subdivided into a Real Time (RT) class and Non-Real Time (NRT) class. VBR (RT) is used for connections in which there is a fixed timing relationship between samples. VBR (NRT) is used for connections in which there is no fixed timing relationship between samples, but that still need a guaranteed [QoS](#).

VCC ♦ **Virtual Channel Connection** Can be a Permanent Virtual Connection (*PVC*) or a Switched Virtual Connection (*SVC*). Any *ATM* connection between two nodes.

VCI ♦ **Virtual Channel Identifier** 16-bit field in the header of an *ATM* cell. The VCI, together with the *VPI*, is used to identify the next destination of a cell as it passes through a series of ATM switches on its way to its destination. ATM switches use the VPI/VCI fields to identify the next network VCL that a cell needs to transit on its way to its final destination. The function of the VCI is similar to that of the *DLCI* in *Frame Relay*.

VCL ♦ **Virtual Channel Link** Connection between two *ATM* devices. A *VCC* is made up of one or more VCLs.

VPI ♦ **Virtual Path Identifier** 8-bit field in the header of an *ATM* cell. The VPI, together with the *VCI*, is used to identify the next destination of a cell as it passes through a series of ATM switches on its way to its destination. ATM switches use the VPI/VCI fields to identify the next VCL that a cell needs to transit on its way to its final destination. The function of the VPI is similar to that of the *DLCI* in *Frame Relay*.

WAN ♦ **Wide-Area Network** Data communications network that serves users across a broad geographic area and often uses transmission devices provided by common carriers. *Frame Relay*, *SMDS*, and *X.25* are examples of WANs.

When using this index, keep in mind that a page number indicates only where referenced material begins. It may extend to the page or pages following the page referenced.

Numerics

- 1577 clients. *See* CIP clients
- 3U expansion slot..... 5
- 4K VCs..... 2
- 6U CompactPCI expansion slot..... 5

A

- AAL5 statistics 86, 148
- AAL5 Statistics dialog
 - GUI..... 86
 - NetWare 148
- ABR configuration..... 69
- ABR service 72, 83, 137, 144
- ABR support 2
- Activating an adapter..... 59
- adapter
 - CPCI network connections 11
 - driver installation
 - HP-UX 41
 - NetWare 107
 - Solaris 31
 - Windows NT 21
 - troubleshooting..... 167
- adapter configuration..... 53, 121
- adapter configuration requirements 54, 122
- adapter features..... 1
- Adapter field 57, 125
- adapter specifications 177
- Adapters dialog box 23, 25
- Add ELAN Clients dialog 76
- adding clients after driver install
 - HP-UX 46
 - NetWare 117
 - NT 28
 - Solaris 37
- address registration 64
- ADTF field..... 70, 73, 137
- API field 104
- Application dialog..... 102
- application settings for CellView 102
- ARP server..... 79, 141
- ARP Server Enable field..... 81, 142
- ARP Server IP Address field 81, 142
- Arrow keys in NetWare 126
- ATM Address field 55
- ATM address, defined 54, 123
- ATM prefix 64
- ATM switch requirements..... 21, 31, 41, 107
- AToM MIB 32, 34

- AUTOEXEC.NCF file 116
- Automatic Switch Back to Primary field 130
- Automatically Switch Back to Primary field..... 62

B

- backup adapter 22, 31, 42, 55, 62, 108, 123, 129
- Backup Adapter No. field 62, 130
- Board Type field..... 62, 129
- boot configuration file, NetWare 116
- boot problems..... 169
- Broadcast field 72, 136
- Bus interface specification 177

C

- cable specification 178
- caution
 - cvconf file 37, 46
 - do not bind IPX for CIP 115
 - electrostatic discharge..... 7
 - load CIP only once 115
 - mixing frame types, NetWare 111
 - wiring connectors 179
 - See also* warnings
- CDF field..... 70, 73, 137
- CellView 3, 53, 121
 - AAL5 statistics 86, 148
 - AAL5 Statistics dialog
 - GUI 86
 - NetWare..... 148
 - Activate option..... 59
 - Add ELAN Clients dialog 76
 - Application dialog 102
 - application settings 102
 - backup adapters..... 55, 123
 - CellView dialog
 - GUI 57
 - NetWare..... 125
 - CellView dialog buttons..... 58
 - CIP CT statistics..... 101, 162
 - CIP CT Statistics dialog 162
 - CIP dialog
 - GUI 80
 - NetWare..... 141
 - CIP PVC Table dialog, NetWare..... 143
 - CIP setup 79, 141
 - CIP statistics 100, 160
 - CIP Statistics dialog
 - GUI 100
 - NetWare..... 161
 - Close option..... 59

Connections dialog.....	103	Physical Setup dialog	
De-Activate option.....	59	GUI.....	60
Debugging dialog.....	104	NetWare	128
debugging messages.....	104, 171	preliminary tasks	54, 122
default SVC settings for LECs.....	69	producing debugging messages	104
displaying signalling settings.....	103	PVC setup for CIP	
features	53, 121	GUI.....	82
Global option.....	59	NetWare	144
Global routines	102	Setup option	127
Insert ELAN Client(s) dialog.....	77	setup routines	59, 127
LEC CCT statistics.....	89, 151	Signalling dialog.....	63
LEC CCT Statistics dialog, NetWare	152	signalling setup.....	62
LEC Default Settings dialog.....	69	Signalling statistics	84, 146
LEC setup	65, 130	Signalling Statistics dialog	
LEC Setup dialog		GUI.....	84
GUI.....	65	NetWare	146
NetWare	130	startup.....	56, 124
LEC statistics	87, 149	Statistics option	58, 59, 127
LEC Statistics dialog		Statistics routines.....	83, 145
GUI.....	88	CellView dialog	
NetWare	150	GUI.....	57
LECS setup	77, 139	NetWare	124
LECS Setup dialog		CellView LECS functions.....	56
GUI.....	78	Change MAC Address field	62
NetWare	140	CIP clients	
LECS statistics	97, 165	ARP server.....	81, 142
LECS Statistics dialog		CIP dialog	
GUI.....	98	GUI.....	80
NetWare	165	NetWare	141
LES CST statistics	97, 164	CIP PVC Table dialog, NetWare	143
LES CST Statistics dialog, NetWare	164	HP-UX	44
LES functions.....	56	NetWare	112, 114, 115
LES setup.....	73, 138	NT.....	24
LES Setup dialog		PVC rate	83, 144
GUI.....	74	PVC setup.....	81, 142
NetWare	138	GUI.....	82
LES statistics.....	95, 163	NetWare	144
LES Statistics dialog		setup.....	79, 141
GUI.....	96	Solaris	35
NetWare	163	CIP Connection Table	101, 162
main dialog		CIP CT statistics	101, 162
GUI.....	57	CIP CT Statistics dialog.....	162
NetWare	124	CIP dialog	80, 141
MPOA Counter statistics	93, 159	CIP PVC Table	
MPOA Counter Statistics dialog		GUI.....	81
GUI.....	94	NetWare	143
NetWare	159	CIP statistics.....	100, 160
MPOA Egress Statistics dialog, NetWare	156	CIP Statistics dialog	
MPOA Ingres Statistics dialog, NetWare.....	155	GUI.....	100
MPOA MPS Statistics dialog, NetWare.....	154	NetWare	161
MPOA statistics		Cisco SSRP support	2
GUI.....	90	Client Connection Table statistics.....	89, 151
NetWare	153	client mappings.....	75
MPOA Statistics dialog, GUI	91	Client Service Table for LES.....	97, 164
MPOA VCC Statistics dialog, NetWare	158	Commit command in NetWare	126
NetWare keyboard commands.....	126	configuration requirements.....	54, 122
physical setup	60, 128	configuring backup adapters.....	55, 123

configuring network physical properties.....	60, 128
configuring network protocols.....	26, 33, 44, 112
configuring network services.....	59, 127
CIP clients	79, 141
LEC	65, 130
LECS	77, 139
LES.....	73, 138
PVCs for CIP	81, 142
PVCs for LEC	70, 134
SVC defaults for LECs.....	69
configuring network UNI signalling.....	62
Connection Table for CIP	101, 162
Connections dialog.....	103
connector	
SC Duplex	12
UTP	13
connectors and cables	
CPCI	11
UTP wiring diagrams.....	179
connectors specification.....	178
CPCI adapter connections	11
CPCI cabinet	7
expansion plate.....	7
expansion slot	7
CPCI cabinet extension bracket.....	8
CPCI expansion slot.....	8
Current MAC Address field	62
cvconf.file	37, 46

D

Data Link field.....	57, 125
data rates.....	1
deactivating an adapter	59
Debugging dialog.....	104
debugging messages.....	104, 171
Default ELAN Type field	79, 140
Default MTU Sizes field.....	79, 140
Default PVC field	72, 137
default SVC traffic rate.....	69, 132
driver	
compatible operating systems	1
configuring	53, 121
enabling SNMP trap generation.....	35
features.....	1
4K VCs	2
ABR support.....	2
CIP	2
framing standards	2
ILMI Service Registry	2
IP-over-ATM.....	2
LECS	2
number of LESs	2
PVCs	2
redundant link support	2
SNMP support	2
SVCs	2
UNI autoconfiguration	2

VPI configuration.....	2
installation	
HP-UX.....	41
NetWare.....	107
Solaris.....	31
Windows NT	21
removing	
HP-UX.....	47
NetWare.....	117
NT	28
Solaris.....	37
requirements	3
setup	59, 127
Driver Version field	58

E

Edit command in NetWare.....	126
Egress statistics	92, 156
ELAN client mappings for LES	75
ELAN Client Mappings Table.....	75
ELAN MTU Size field	67, 75, 133, 139
ELAN Name field.....	67, 74, 132, 139
ELAN services	56, 73, 77, 124, 138, 139
ELAN Type field.....	67, 75, 133, 139, 140
electromagnetic energy warning.....	6
electrostatic discharge precautions.....	7
EMI protection	6
Enable Advanced Settings field.....	103
Enable ILMI Address Registration field.....	64
Enable IP-over-ATM field.....	80, 141
Enable LEC field	66, 131
Enable LECS field	78, 140
Enable LES field	74, 138
Enable MPOA field	66, 132
Enable UNI Auto-Configuration field	64
encapsulation	72, 83, 136, 144
Encapsulation field	72, 83, 136, 144
End Pts on a Pt-Mpt field.....	103
end station ATM address	54, 123
end station identifier (ESI).....	55, 123
Enhanced VC field.....	67, 132
ENTER key in NetWare	126
error tracking.....	32, 35
errors, troubleshooting	167
ESC key in NetWare	126
ESI Selector field.....	79, 140
ESI/Selector field.....	68, 81, 134, 142
ESI/Selector value	55, 123
Ethernet MTU Size field.....	140
ETHERTSM.NLM file.....	108, 116
Exit command in NetWare.....	126
explosive atmosphere warning	6
extension bracket for CPCI cabinet.....	8

F

F1 key in NetWare.....	126
F10 key in NetWare	126
F2 key in NetWare.....	126

Factory MAC Address field.....	62	initializing backup adapter	22, 31, 42, 108
fail-over.....	55, 123	initializing clients.....	22, 32, 42, 109
features.....	1	Insert ELAN Client(s) dialog.....	77
CellView.....	53, 121	installation	
driver	1	CompactPCI adapter	5
LAN Emulation	2	electrical warning	7
MIBs	32	network connections for CPCI adapter.....	11
SNMP management	32	installing the driver	
trap generation.....	32	HP-UX	41
Framing field	61, 129	adding clients after install.....	46
framing standards.....	2	CIP clients	44
FRTT field.....	70, 72, 137	completing installation.....	46
G		LECs.....	44
gathering IP address information.....	21	network protocols.....	44
global CellView settings	102	prerequisites.....	41
grounding the instrument.....	6	redundancy support.....	42
H		starting	42
hardware		verifying	45
requirements.....	3	NetWare	107
hardware installation		adding clients after install.....	117
CmpactPCI adapter installation.....	5	backup adapter	113
electrical warning.....	7	CIP clients	112, 114, 115
grounding the instrument	6	client channels.....	113
live circuit warning	6	completing.....	117
network connections for CPCI adapter	11	ELAN type	113
safety precautions	5	Integrated driver	109
Help command in NetWare	126	IP interface	112
host adapter not found.....	170	LECs.....	112
Host Bus interface specification.....	177	LES/LECS.....	114
HP-UX		loading the driver	114
adding clients after install	46	network protocols.....	112
CellView	53	Novell Support Pack	108
configuring clients manually	45	ODI driver	118
configuring network protocols.....	44	redundancy support.....	108
driver features.....	1	starting	110
driver installation	41	system MTU	116
driver removal	47	NT	
message logging	46	adding clients after install.....	28
system requirements	3	CIP clients	24
verifying driver install	45	LECs.....	24
I		SNMP	24
ICR field	70, 72, 137	Solaris	31
ID 2.0 driver	1	adding clients after install.....	37
ifconfig command	45	backup adapter	34
ifStackTable MIB.....	32, 34	CIP clients	35
ILMI	62	completing installation.....	36
ILMI address registration	64	IP interface	35
ILMI auto-configuration	64	LECs.....	35
ILMI field.....	104	MIBs.....	34
ILMI polling	64	network protocols.....	33
ILMI Port Change Detection field.....	64	number of adapters	33
ILMI Service Registry	2	number of primary adapters.....	34
INETCFG.NCF file	116	prerequisites.....	31
Ingress cache	92, 155	redundancy support.....	31
Ingress statistics	92, 155	SNMP	34
		starting	32
		trap generation	35

Windows NT.....	21	LECS Setup dialog	
completing installation.....	27	GUI.....	78
IP interface.....	26	NetWare.....	140
network protocols.....	26	setup.....	77, 139
prerequisites.....	21, 107	well known address.....	78, 140
redundancy support.....	22	LECS functions.....	56, 124
starting.....	23	LECS statistics.....	97, 165
Integrated Driver.....	1	LECS Statistics dialog	
Integrated Local Management Interface.....	62	GUI.....	98
Interphase ATM Setup.....	24	NetWare.....	165
Interrupt Level field.....	62	LECS/LES ATM Address field.....	68, 133, 134
interrupt pin.....	177	LED	
IP address		description.....	167
HP-UX.....	44	interpreting.....	167
Hp-UX.....	44	specification.....	177
NetWare.....	112	state and function.....	167
NT.....	26	ledbg command.....	45
IP Address field.....	80, 81, 82, 141, 142, 144	Left Arrow key in NetWare.....	126
IP interface for NetWare.....	112	LES	
IP interface for Solaris CIP clients.....	35	client mappings.....	75
IP interface for Solaris LECS.....	35	LES Setup dialog	
IP interface formula.....	35	GUI.....	74
IP-over-ATM clients. <i>See</i> CIP clients		NetWare.....	138
IPX binding.....	115	setup.....	73, 138
K		LES Client Service Table.....	97, 164
keyboard commands for NetWare.....	126	LES connection.....	68, 133
L		LES CST statistics.....	97, 164
L3MTU size field.....	68	LES CST Statistics dialog, NetWare.....	164
LAN Emulation		LES functions.....	56, 124
features.....	2	LES statistics.....	95, 163
LAN Emulation Client. <i>See</i> LEC		LES Statistics dialog	
LAN Emulation Configuration Server. <i>See</i> LECS		GUI.....	96
LAN Emulation Server. <i>See</i> LES		NetWare.....	163
LANE V2 Capable field.....	66, 132	link failure.....	55, 123
LEC.....	2	Link LED.....	167, 177
HP-UX.....	44	live circuit warning.....	6
LEC Default Settings dialog.....	69	LLC_Snap encapsulation.....	72, 83, 136, 144
NetWare.....	112	LOAD CELLVIEW command.....	124
NT.....	24	load install command.....	110, 117
PVC rate.....	72, 137	load nwconfig command.....	110, 117
PVC setup.....	70, 134	M	
setup.....	65, 130	MAC Address Change field.....	62
Solaris.....	35	MAC Address Current field.....	62
SVC traffic rate.....	69, 132	MAC Address field.....	58, 125
LEC CCT statistics.....	89, 151	LEC.....	66, 131
LEC CCT Statistics dialog, NetWare.....	152	PVC table.....	71, 136
LEC MIB.....	32, 34	MAC address of adapter.....	55, 123
LEC Setup dialog		MAC Address Use factory field.....	62
GUI.....	65	main CellView dialog	
NetWare.....	130	GUI.....	57
LEC statistics.....	87, 149	NetWare.....	124
LEC Statistics dialog		Management Information Bases <i>See</i> MIBS	
GUI.....	88	MCR field.....	70, 72, 137
NetWare.....	150	mechanical specification.....	178
LEC Unit field.....	131	Memory specification.....	177
LECS.....	2	message logging in HP-UX.....	46

MIBs.....	34	network configuration.....	53, 121
minimum system requirements	3	network connection	1
modifying equipment.....	6	network connections	
Move command in NetWare.....	126	CPCI adapter.....	11
MPOA Counter statistics.....	93, 159	network interface	
MPOA Counter Statistics dialog		Hp_UX.....	44
GUI.....	94	NetWare	112
NetWare.....	159	NT.....	26
MPOA Egress statistics.....	92, 156	Solaris	35
MPOA Egress Statistics dialog, NetWare	156	network interface specification	177
MPOA field.....	66, 132	network prefix	55, 123
MPOA Ingres Statistics dialog, NetWare	155	Network Prefix & ESI/Selector.....	68, 81, 134, 142
MPOA Ingress statistics.....	92, 155	Network Prefix field.....	64, 79, 140
MPOA MPS statistics	91, 153	network problems.....	170
MPOA MPS Statistics dialog, NetWare.....	154	network protocols for HP-UX.....	44
MPOA statistics	90, 153	network protocols for NetWare.....	112
MPOA Statistics dialog, GUI.....	91	network protocols for NT.....	26
MPOA VCC statistics.....	93, 158	network protocols for Solaris.....	33
MPOA VCC Statistics dialog, NetWare.....	158	Next command in NetWare	126
MPS statistics	91, 153	Novell Support Pack.....	108
MSM.NLM file.....	108, 116	NRM field.....	70, 72, 137
MTU size	67, 68, 133	Null encapsulation.....	72, 83, 136, 144
default ELAN	79, 140		
for ELAN served by LES.....	75, 139	O	
MTU Size field.....	75	OC-3c signal.....	61, 129
strict	75, 139	operating environment.....	178
MTU Size field	67, 68, 133		
MTU system configuration for NetWare.....	116	P	
multiple adapters		P key in NetWare	126
HP-UX.....	44	PCI master specification	178
NetWare.....	113	PCI slave specification	177
NT.....	25	permanent ELAN clients.....	75
Solaris.....	33	Permanent Virtual Circuits. <i>See</i> PVCs	
multiplexing standard	61, 129	physical setup	60, 128
N		Physical Setup dialog	
N key in NetWare.....	126	GUI.....	60
NDIS ATM driver	2	NetWare	128
netstat command	45	pin assignments.....	179
NetWare		pkgadd command.....	32
adding clients after install	117	pkginfo command	32
boot configuration file	116	pkgrm command	37
CellView.....	121	power requirements	177
CellView keyboard commands.....	126	precautions when installing hardware.....	5
configuring network protocols.....	112	Previous command in NetWare	126
driver features.....	1	primary adapter.....	55, 123
driver installation	107	problems and solutions	167
driver names.....	111	product features	1
driver removal	117	Pt-to-Mpt field.....	103
Integrated Driver.....	109	Pt-to-Pt field.....	103
LOAD CELLVIEW command	124	PVC broadcast setting	136
network IPX binding	115	PVC Only field	66, 80, 131, 141
ODI Driver.....	118	PVC Rate field.....	72, 83, 137, 144
protocols and parameters dialog.....	112	PVC Settings dialog	
system requirements	4	GUI.....	71
NetWare Support Pack.....	108	NetWare	136
network address, defined.....	54, 123	PVC setup	
		CIP.....	81, 142
		adding PVCs.....	82, 143

deleting PVCs	83, 145
modifying PVCs.....	82, 143
LEC	70, 134
adding PVCs.....	71, 135
deleting PVCs.....	73, 137
modifying PVCs.....	71, 135
PVC Settings dialog	71, 136
PVC Table	
CIP client.....	143
CIP clients	81
LEC	70, 134
PVC Table Setup dialog, NetWare.....	135
R	
Rate field	69, 132
CIP.....	83, 144
LEC	72, 137
RDF field	70, 73, 137
reboot command	37
redundancy..	22, 31, 42, 55, 62, 108, 123, 129, 130
redundant link support.....	2, 62, 129
Register LECS field	140
Register Nonstandard Prefixes field.....	64
removing driver	
HP-UX	47
NetWare	117
Solaris	37
Windows NT.....	28
requirements	
configuration.....	54, 122
system	3
restart_signald command	64
restarting signalling.....	64
RFC 1215.....	32
RFC 1577 clients. <i>See</i> CIP clients	
RIF field	70, 73, 137
Right Arrow key in NetWare.....	126
RJ-45 connections.....	11
running CellView.....	56, 124
S	
safety precautions	5
SC Duplex connections.....	11, 12
SDH framing	61, 129
secondary adapter	22, 31, 42, 55, 108, 123
Sel field	125
Select command in NetWare	126
selector value.....	55, 123
Service field (UBR or ABR)	
CIP PVC.....	83, 144
LEC PVC	72, 137
Service Registry MIB	2
Set Table Font field.....	103
setting up LEC.....	65, 130
setting up LECS.....	77, 139
setting up LES	73, 138
setting up network services	59, 127
setting up physical properties	60, 128
setting up PVCs for CIP	81, 142
setting up PVCs for LEC	70, 134
setting up UNI signalling.....	62
shutdown command	36, 37
signald command.....	45
signald.log file.....	46
signalling	
connection settings	103
setup	62
Signalling dialog.....	63
Signalling field.....	104
signalling restart	64
Signalling statistics	84, 146
Signalling Statistics dialog	
GUI.....	84
NetWare	146
Simple Management Network Protocol <i>See</i> SNMP management	
SNMP management	32, 34
SNMP support.....	2, 24
SNMP trap generation	32, 35
software driver. <i>See</i> driver	
Solaris	
adding clients after install.....	37
CellView	53
driver features	1
driver installation	31
driver removal.....	37
rebooting the machine.....	36
system requirements	3
SONET framing	61, 129
SONET MIB	32, 34
specifications	177
standards compliance	177
start command.....	46
starting CellView.....	56, 124
Stat Refresh Rate field.....	102
Static Network Prefix field	64
statistics for drivers.....	83, 145
Status field (adapter status).....	58, 125
Status LED.....	167, 177
STM-1 signal	61, 129
stop command	46
storage environment.....	178
Strict	
ELAN Name field	75, 139
MTU Size field	75, 139
subnet mask	
Hp-UX	44
NetWare	112
Subnet Mask field.....	80, 141
substituting parts.....	6
SUNI Framing.....	61
SUNI Framing field	129
Support Pack for NetWare.....	108
SVC Default Rate field.....	69, 132
SVC default setting setup	69

SVC Range field	63
SVC Rate field, CIP.....	81, 142
swinstall command	43
Switch Config field.....	58, 126
switch requirements.....	21, 31, 41, 107
swlist command	43
swremove command	47
system requirements	3
T	
TAB key in NetWare	126
TBE field.....	70, 72, 137
TCP/IP	
NetWare Server	112
Windows NT	26
TCP/IP on the server.....	107
temporary ELAN clients	76
Token Ring MTU Size field	140
trap generation	32, 35
TRM field.....	70, 73, 137
troubleshooting	
boot problems	169
clients not connecting (GUI)	172, 174, 175
clients not connecting (NetWare).....	173, 174, 175
computer does not boot.....	169
link problems.....	168
network application not working.....	176
network problems	170
no communication with other hosts.....	171
no host adapter found	170
status problems	168, 169
TX/RX	
UTP connectors	179
Type field (adapter type).....	57, 125
U	
UBR service	72, 83, 137, 144
UNI autoconfiguration	2, 64
UNI Revision field	63
UNI revision support	64
UNI signalling setup.....	62
UNI switch support.....	21, 31, 41, 107
unshielded twisted pair connector	13
Use 'Well Known Address' field	78, 140
UTP connections	13
wiring diagrams	179
V	
V2 Capable field	66, 132
VCC statistics	93, 158
VCI field	63, 72, 83, 136, 144
verifying driver installation for HP-UX	45
virtual circuit identifier	63
VPI configuration.....	2, 61, 129
VPI field.....	61, 63, 129
W	
warning	
electrical shock	7
electromagnetic energy.....	6
explosive atmosphere	6
grounding the instrument	6
live circuits	6
modifying equipment	6
substituting parts.....	6
well-known address.....	64
Windows 2000.....	2
Windows NT	
adding clients after install	28
CellView.....	53
configuring network protocols.....	26
driver features	1
driver installation	21
driver removal	28
system requirements.....	3