

4815/4825/4875 EISA ATM Adapter Users Guide

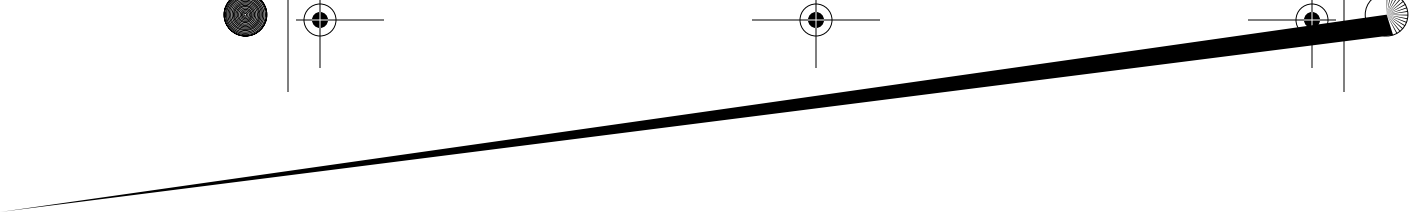

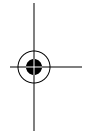

4815/4825/4875 EISA ATM Adapter Users Guide



Document No. UG04875-000, REVA

Print Date: October 15, 1997

Preliminary



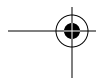
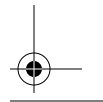
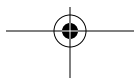
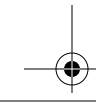
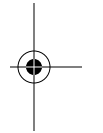
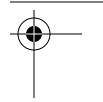
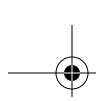
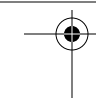

Copyright Notice

© 1997 by Interphase Corporation. All rights reserved.

Printed in the United States of America, 1997.

This manual is licensed by Interphase to the user for internal use only and is protected by copyright. The user is authorized to download and print a copy of this manual if the user has purchased one or more of the Interphase adapters described herein. All copies of this manual shall include the copyright notice contained herein. No part of this manual, whether modified or not, may be incorporated into user's documentation without prior written approval of

Interphase Corporation
13800 Senlac
Dallas, Texas 75234
Phone: (214) 654-5000
Fax: (214) 654-5500

Disclaimer

Information in this manual supersedes any preliminary specifications, preliminary data sheets, and prior versions of this manual. While every effort has been made to ensure the accuracy of this manual, Interphase Corporation assumes no liability resulting from omissions, or from the use of information obtained from this manual. Interphase Corporation reserves the right to revise this manual without obligation to notify any person of such revision. Information available after the printing of this manual will be in one or more Read Me First documents. Each product shipment includes all current Read Me First documents. All current Read Me First documents are also available on our web site.

THIS MANUAL IS PROVIDED "AS IS." INTERPHASE DISCLAIMS ALL WARRANTIES, EXPRESS OR IMPLIED, INCLUDING THOSE OF MERCHANTABILITY AND FITNESS FOR A PARTICULAR PURPOSE OR ARISING FROM A COURSE OF DEALING, USAGE, OR TRADE PRACTICE.

IN NO EVENT SHALL INTERPHASE BE LIABLE FOR ANY INDIRECT, SPECIAL, CONSEQUENTIAL, OR INCIDENTAL DAMAGES, INCLUDING, WITHOUT LIMITATION, LOST PROFITS OR LOSS OR DAMAGE TO DATA ARISING OUT OF THE USE OR INABILITY TO USE THIS MANUAL, EVEN IF ADVISED OF THE POSSIBILITY OF SUCH DAMAGES.

Trademark Acknowledgments

Interphase® and Syncard® are registered trademarks and CellView™, (i)chip™, ADSLWatch™, ADSLEye™, SynWatch™, SynEye™, FibreView™, and the Interphase logo are trademarks of Interphase Corporation.

Microsoft®, MS-DOS®, Windows®, and Windows NT® are registered trademarks of Microsoft Corp.

Novell® and NetWare® are registered trademarks of Novell, Inc.

Solaris® and NFS® are registered trademarks and SunOS™ and ONC™ are trademarks of Sun Microsystems, Inc. Sun is a trademark or registered trademark of Sun Microsystems, Inc.

SPARC® is a registered trademark of SPARC International, Inc. SPARCstation™ and UltraSPARC™ are trademarks of SPARC International, Inc., licensed exclusively to Sun Microsystems, Inc.

LattisCell™, EtherCell™, Bay Networks™, and SAHI™ are trademarks of Bay Networks, Inc.

UNIX® is a registered trademark in the United States and other countries, licensed exclusively through X/Open Company Ltd.

IBM® and OS/2® are registered trademarks and AIX™ and PowerPC™ are trademarks of International Business Machines Corporation.

HP-UX® is a registered trademark and Tachyon™ and Precision Bus™ are trademarks of Hewlett-Packard Company.

Intel® and Pentium® are registered trademarks of Intel Corporation.

TI® is a registered trademark of Texas Instruments.

Compu-shield® is a registered trademark of Stewart Connectors Systems, Inc.

Tundra® is a registered trademark and Universe™ is a trademark of Tundra Semiconductor Corporation.

Ethernet® is a registered trademark of Xerox Corporation.

DG/UX® and AViiON® are registered trademarks of Data General Corporation.

Apple® and Power Macintosh® are registered trademarks and Macintosh™, MacOS™, Mac™, AppleTalk™, and Open Transport™ are trademarks of Apple Computer, Inc.

NCR® is a registered trademark of NCR Corporation.

Silicon Graphics® is a registered trademark and SGI™, Indigo™, Indy™, Indigo²™, IRIX™, IRIS™, IRIS Indigo™, Challenge™, and Challenge M™ are trademarks of Silicon Graphics, Inc.

ALPHA™ is a trademark of Digital Equipment Corporation.

Gadzoox™ is a trademark of Gadzoox Microsystems, Inc.

Seagate™ and Barracuda™ are trademarks of Seagate Technology, Inc.

ST® is a registered trademark of AT&T.

SCO, The Santa Cruz Operation, SCO OpenServer, and UnixWare are trademarks or registered trademarks of The Santa Cruz Operation, Inc.

SUPERNET™ is a trademark of Advanced Micro Devices, Inc.

Cisco® is a registered trademark and Cisco Systems™ is a trademark of Cisco Systems, Inc.

Adobe® and Acrobat® are registered trademarks of Adobe Systems Incorporated.

CompactPCI® and PICMG® are registered trademarks of the PCI Industrial Computer Manufacturers Group.

Assistance

Product Purchased from Reseller

Contact the reseller or distributor if

- You need ordering, service or any technical assistance.
- You received a damaged, incomplete or incorrect product.

Product Purchased Directly from Interphase Corporation

Contact Interphase Corporation directly for assistance with this, or any other Interphase Corporation product. Please have your purchase order and serial numbers ready.

Customer Support

United States:	Telephone: (214) 654-5555
	Fax: (214) 654-5500
	E-Mail: intouch@iphase.com
United Kingdom:	Telephone: + 44 (0) 1869-321222
	Fax: + 44 (0) 1869-247720
France:	Telephone: + 33 (0) 1 41 15 44 00
	Fax: + 33 (0) 1 41 15 12 13
Asia/Pacific Rim:	Telephone: + 81 35423 6513
	Fax: + 81 3 5423 6511

World Wide Web

<http://www.iphase.com>

Anonymous FTP Server

<ftp://iphase.com>

Safety Precautions

The following general safety precautions must be observed during all phases of operation of this equipment. Failure to comply with these precautions or with specific warnings elsewhere in this manual violates safety standards of design, manufacture, and intended use of the equipment. Interphase Corporation assumes no liability for the user's failure to comply with these requirements. You, as the user of the product, must observe all stated warnings and safety precautions in order to safely operate the equipment in your environment.

Do Not Substitute Parts or Modify Equipment

Because of the danger of introducing additional hazards, do not install substitute parts or perform any unauthorized modification of the equipment. Contact your local Interphase representative for service and repair to ensure that safety features are maintained.

Ground the Instrument

To minimize shock hazard, the equipment chassis and enclosure must be connected to an electrical ground. The power cable must either be plugged into an approved three-contact electrical outlet or used with a three-contact to two-contact adapter, with the grounding wire (green) firmly connected to an electrical ground (safety ground) at the power outlet.

Do Not Operate in an Explosive Atmosphere

Do not operate the equipment in the presence of flammable gases or fumes. Operation of any electrical equipment in such an environment constitutes a definite safety hazard.

Keep away from Live Circuits

Do not install or replace the component with power cable connected. Under certain conditions, dangerous voltages may exist even with the power cable removed. To avoid injuries, always disconnect power and discharge circuits before touching them.

Observe Dangerous Procedure Warnings

Warnings precede potentially dangerous procedures throughout this manual. Instructions contained in the warnings must be followed. You should also employ all other safety precautions which you deem

necessary for the operation of the equipment in your operating environment.



WARNING

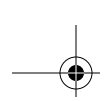

CLASS A FCC Regulatory Compliance

The 4815 adapter from Interphase has been tested and found to comply with the limits for a Class A digital device, pursuant to part 15 of the FCC Rules. These limits are designed to provide reasonable protection against harmful interference when the equipment is operated in a commercial environment. This equipment generates, uses, and can radiate radio frequency energy and, if not installed and used in accordance with the instruction manual, may cause harmful interference to radio communications. Operation of this equipment in a residential area is likely to cause harmful interference in which case the user will be required to correct the interference at his own expense.

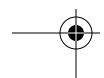

CLASS B FCC Regulatory Compliance

Tested To Comply With FCC Standards

The 4815 adapter from Interphase complies with Part 15 of the FCC Rules. Operation is subject to the following two conditions:

- This device may not cause harmful interference.
- This device must accept any interference received, including interference that may cause undesired operation.

Radio Frequency Interference Statement

This equipment has been tested and found to comply with the limits for a Class B digital device, pursuant to Part 15, Subpart B of the FCC Rules. This equipment generates, uses, and can radiate radio frequency energy. If not installed and used in accordance with the instructions, it may cause interference to radio communications.

The limits are designed to provide reasonable protection against such interference in a residential situation. However, there is no guarantee that interference will not occur in a particular installation. If this equipment does cause interference to radio or television reception, which can be determined by turning the equipment on and off, the user is encouraged

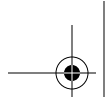

Interphase Fiber Products' Compliance

All Interphase fiber products comply with IEC regulations 825-1 and 825-2 for Class 1 laser devices.

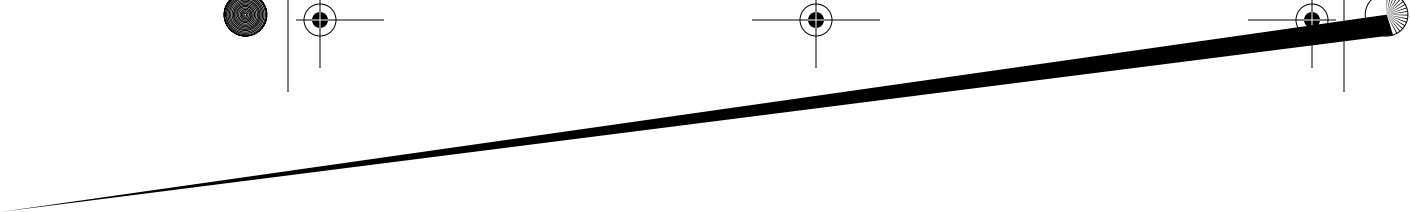
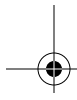
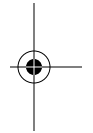

Declaration of Conformity

(according to ISO/IEC Guide 22 and EN 45014)

Manufacturer's Name: Interphase Corporation
**Manufacturer's Address and
Phone Number:** 13800 Senlac
Dallas, Texas 75234
U.S.A.
214/654-5000

declares, that the product:

Product Name: EISA ATM IChip FIBER

Model Number: 4815

conforms to the following Standards:

Safety: EN 60950:1988 + A1, A2
IEC 825 -1 & -2 1993

EMC: EN 55022:1988 class B
EN 50082-1 Part 1 1992

Supplementary Information:

This product complies with the requirements of the **Low Voltage Directive 73/23/EEC** and the **EMC directive 89/336/EEC**.

Dallas, June 18, 1996

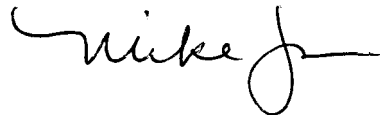

Mike Jobe, Quality Manager

European Contact:

Interphase International
Astral House, Granville Way, Bicester, Oxon, England OX6 0JT
Phone: +44 (0) 1869-321222; Fax:+44 (0) 1869-247720

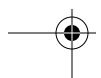
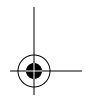
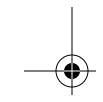
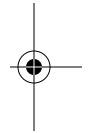
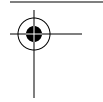
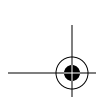
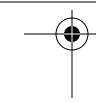

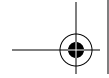

Contents

List of Figures	vii
Preface	ix
Audience	ix
Icon Conventions	ix
Text Conventions	x
CHAPTER 1 Introduction	
Overview	1
Software Drivers	2
ATM Switch	4
ATM Address	4
CHAPTER 2 Hardware Installation	
Overview	6
Inspecting the Adapter	6
Installing the Hardware	7
Running the EISA Configuration Utility	9
Connecting the Adapter to the Network	11
CHAPTER 3 Quick Driver Installation Guides	
Overview	13
Windows NT	14
IRIX	15
HP-UX 9.05/9.07	16
HP-UX 10.10	17
NetWare Server	18



Contents

CHAPTER 4 Windows NT Driver Installation

Overview 19
Driver Requirements..... 20
Installing the Driver..... 21
Configuring the Protocols..... 23
Removing a Driver..... 25

CHAPTER 5 IRIX Driver Installation

Overview 27
Driver Requirements..... 28
Configuring the Network Interface..... 29
Installing the Driver..... 31
Automating Startup and Shutdown 35
Setting the European STM-1 mode..... 38

CHAPTER 6 HP-UX Driver Installation

Overview 39
Driver Requirements..... 40
Installing the Driver for HP-UX 9.05/9.07 41
 Configuring the Network Interface..... 44
 Removing a Driver from HP-UX 9.05/9.07 47
Installing the Driver for HP-UX 10.10 48
 Configuring the Network Interface..... 51
 Removing a Driver from HP-UX 10.10..... 54

CHAPTER 7 CellView Utility

Overview 57
Getting Started..... 59
Setup 62
 UNI Signalling..... 63
 LAN Emulation Clients..... 65

Contents

IP over ATM Client and Server	70
ELAN Services	73
LAN Emulation Configuration Server	74
LAN Emulation Servers.....	76
Statistics	81
Global Settings.....	82
Application	82
Connections	83
Debugging.....	84

CHAPTER 8 NetWare Server Driver Installation

Overview.....	87
Driver Requirements.....	88
Installing the Driver	88
Configuring Protocols and Parameters.....	91
Editing AUTOEXEC.NCF.....	95
Changing a LEC to an IP over ATM Client	96
Configuring Multiple Adapters	97
Configuring the Adapter to the Network	101
Removing a Driver	102

CHAPTER 9 CellView Utility for NetWare Servers

Overview.....	103
Getting Started	104
Statistics Option.....	106
Setup Option.....	106
Setup.....	107
Confirming Edits.....	107
LAN Emulation Clients	108
LEC PVC Table	111
IP over ATM Client and Server	115
IP over ATM PVC Table.....	117
ELAN Services	121

Contents

LAN Emulation Configuration Server	121
LAN Emulation Servers	123
Statistics.....	126

CHAPTER 10 Troubleshooting

Verifying Driver Installation.....	127
LED State and Function.....	129
Bootup Problems.....	131
Network Problems	133

APPENDIX A Specifications

Adapter	137
Operating Environment.....	138
Storage Environment	138
Network Connections	139

APPENDIX B UTP Cabling

Straight-through Cable	141
Crossover Cable	141
RJ-45 Connector Pinouts	142

APPENDIX C ATM Technology Overview

Introduction to ATM.....	143
Virtual Circuits	144
Virtual Circuit Connections	144
Permanent Virtual Circuits.....	145
Switched Virtual Circuits	146
Fixed-Length Cells	147
Scalability.....	148
ATM Layers	148
Physical Layer	149
ATM Layer	150

Contents

ATM Adaptation Layer	150
SONET/SDH.....	153
Integrated Local Management Interface	153
LAN Emulation	154
LAN Emulation Services.....	157
LAN Emulation Configuration Server	157
LAN Emulation Server	158
Broadcast and Unknown Server	159
LAN Emulation Protocol.....	159
1. Initialization	159
2. Configuration	160
3. Joining	160
4. Registration and BUS Initialization.....	160
5. Data Movement	160
LAN Applications	161
For More Information	161
Glossary	163
Index	179

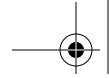

Contents



Preface

Audience

The terminology and structure of this users guide is directed to system administrators or those with equivalent technical experience, and assumes that its audience has a general understanding of computing and networking terminology. There is a general glossary of terms in the back of this users guide as well as an introductory tutorial for ATM networking. If you need more information, see the following web sites:

- **ATM Networking**

<http://www.atmforum.com>

- **Networking Glossary**

<http://www.ctcnet.com/tips/glossary.htm>

- **Computing Dictionary**

<http://wfn-shop.Princeton.EDU/foldoc/>

Icon Conventions

Icons draw your attention to especially important information:



NOTE

The Note icon indicates important points of interest related to the current subject.

Text Conventions

**CAUTION**

The Caution icon brings to your attention those items or steps that, if not properly followed, could cause problems in your machine's configuration or operating system.

**WARNING**

The Warning icon alerts you to steps or procedures that could be hazardous to your health, cause permanent damage to the equipment, or impose unpredictable results on the surrounding environment.

Text Conventions

The following conventions are used in this manual. Computer-generated text is shown in typewriter font. Examples of computer-generated text are: program output (such as the screen display during the software installation procedure), commands, directory names, file names, variables, prompts, and sections of program code.

Computer-generated text example

Commands to be entered by the user are printed in **bold Courier** type. For example:

```
cd /usr/tmp
```

Pressing the return key (↵ **Return**) at the end of the command line entry is assumed, when not explicitly shown. For example:

/bin/su

is the same as:

/bin/su ↵ **Return**

Required user input, when mixed with program output, is printed in **bold Courier** type. References to UNIX programs and manual page entries follow the standard UNIX conventions.

When a user command, system prompt, or system response is too long to fit on a single line, it will be shown as

```
Do you want the new kernel moved into
\ vmunix?[y]
```

with a backslash at either the beginning of the continued line or at the end of the previous line.

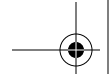

Text Conventions

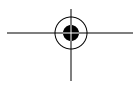

Introduction

1

Adapter Overview

There are three types of EISA ATM adapters from Interphase, the 4815, the 4825, and the 4875. The 4815 and the 4875 support a data rate of 155 Mbps over fiber and copper. The 4825 adapter supports a data rate of 25 Mbps over copper only. All adapters provide a full range of ATM network communications. The 4875 has the (i)chip+™ which includes hardware-based ABR in compliance with the ATM Forum Traffic Management 4.0 specification.

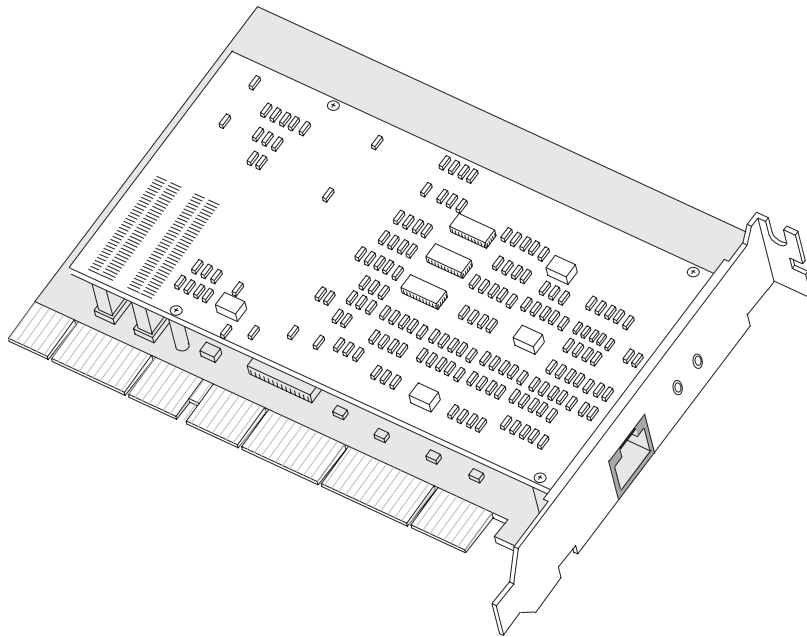

Figure 1-1. EISA ATM Adapter

Software Drivers

The adapters are a single-slot board based on the Interphase (i)chip™ SAR (segmentation and reassembly) technology which converts upper layer PDUs (protocol data units) to and from ATM cells for optimal performance. Packet-to-cell fragmentation and cell-to-packet reassembly functions take place in the hardware using Interphase's custom DMA ASIC which integrates the EISA bus transfers with on-board SAR activity.

Most of the examples and diagrams in this manual refer to the 4875 adapter. This information applies equally to the 4815 and the 4825 except where noted. The network connections available for the boards are shown in the table below.

	Data Rate	Interface	Connections
4815	155 Mbps	SONET OC-3c Fiber SONET OC-3c Fiber SONET UTP	SC Duplex, Single-mode SC Duplex, Multimode RJ-45, UTP Cat 5
4825	25.6 Mbps	AF-PHY-0040.00 UTP	RJ-45, UTP Cat 3, 4, or 5
4875	155 Mbps	SONET OC-3c Fiber SONET UTP	SC Duplex, Multimode RJ-45, UTP Cat 5

Software Drivers

Detail instructions for installing the drivers are located in their respective chapters in this users guide. Brief installation guides for all the drivers are located in Chapter 3 beginning on page 13. The drivers available for the EISA ATM adapters include,

- Windows NT version 3.51 or 4.0
- NetWare Server version 3.12 and 4.1
- IRIX™ version 5.3 and 6.2
- HP-UX™ version 9.07 and 10.10

The drivers provide standards-based LAN Emulation and IP-ATM connectivity to an ATM network using Switched Virtual Circuit (SVC) communications. Except where noted, up to eight adapters can be installed per machine with up to four LAN Emulation Clients (LECs) and one IP-ATM (RFC-1577) Client per adapter. A LAN Emulation Configuration Server (LECS), up to eight LAN Emulation Servers (LESs) with Broadcast and Unknown frame Server (BUS), and an IP-ATM server can be enabled per adapter. Dialogs are included for setting up Permanent Virtual Circuits (PVCs) with other endstations based on RFC-1483 standards. Basic features for the drivers are as follows:

- LAN Emulation Clients
 - Ethernet[®]
 - Token Ring
- LAN Emulation services (LES, BUS and LECS)
 - Ethernet
 - Token Ring
- IP-ATM (RFC-1577) Client
- IP-ATM (RFC-1577) Server
- PVC configuration tables

The installation package also includes CellView[™] ID1.x, a cross-platform, graphical utility for configuring the adapters to the network. It can also be used to display pertinent statistics about the adapters and various system services.

Host Requirements

Host Requirements

The adapters must be installed in a host system that meets the following minimum requirements:

Item	Minimum
Type of Computer	EISA with at least 1 available 32-bit slot
Minimum CPU	386
Speed of Processor	25 MHz
RAM	See software driver installation chapters

ATM Switch

Your ATM switch must be capable of supporting the UNI 3.0/3.1 signalling standard for SVCs. Some switch vendors allow the mixing of the two standards and some require that all ports be set to either UNI 3.0 or UNI 3.1. Check your switch documentation for the proper settings. The default setting for the adapter is UNI 3.0.

ATM Address

The unique network address for an endstation is composed of a 13-byte network prefix and a 6-byte endstation identifier (ESI) appended with a 1-byte selector value, as shown in the upper box of Figure 1-2. The lower boxes show the ATM address broken down in its two most common configurations, the Network Prefix and the ESI/Selector value. The MAC address and ESI values for Token Ring are displayed and entered in non-canonical format.

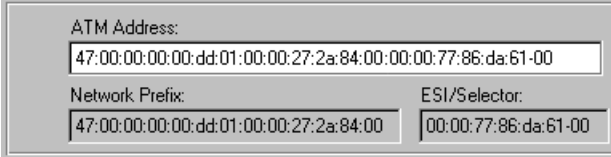

ATM Address:
47:00:00:00:00:dd:01:00:00:27:2a:84:00:00:00:77:86:da:61-00

Network Prefix: 47:00:00:00:00:dd:01:00:00:27:2a:84:00 ESI/Selector: 00:00:77:86:da:61-00

Figure 1-2. Breakdown of the ATM Address

The Network Prefix is the link address for the adapter as set by the ATM switch. The ESI value represents the MAC address of the adapter and the Selector value is a pointer to clients and services located within the endstation. The Selector value for the endstation itself is always 00. The Selector values for the clients and services located within an endstation are shown in the table below:

Item Number	Range of Selector Values
LEC1 – LEC4	0 – 3
LES1 – LES8	20 – 27
BUS1 – BUS8	40 – 47

Hardware Installation

2

Overview

These adapters can be installed in any EISA expansion slot on the motherboard. This chapter describes the procedures for physically installing the adapter and include

- Inspecting the adapter
- Installing the adapter in a host expansion slot
- Connecting the adapter to the network

The only tools required are a grounding strap and a #1 Phillips screwdriver.

For adapter specifications, see *Adapter Specifications* on page 121.

Inspecting the Adapter

Before installing the adapter in your computer, you need to visually inspect it for damage that might have occurred during shipment from the factory. The adapter is packed in an antistatic bag to protect it during shipment. Keep the adapter in its protective antistatic bag until you are ready to install it in the host computer.



CAUTION

To prevent damage to the adapter due to electrostatic discharge, wear a grounding strap and handle the adapter only by its edges. Do not touch its components or any metal parts other than the faceplate.

1. Open the shipping container and carefully remove its contents.
2. Inspect each item for damage. If you find any omissions or damage, contact your network supplier and the carrier (for example, UPS or Federal Express) that delivered the package.

Installing the Hardware



WARNING

Your computer operates at voltages that can be lethal. Before you remove the computer cover, carefully review the following procedures and observe all cautions and warnings to protect yourself and to prevent damage to the system. Use only insulated or nonconductive tools.

1. Turn off the computer's power switch and unplug the unit from its power source.
2. Remove the computer's cover according to the manufacturer's instructions.

Continue the installation with the steps in the next section.

Connecting the Adapter to the Network

With the adapter installed as discussed in the previous section, you are now ready to connect the adapter to the network. The cables and connectors required for each adapter are:

Adapter	Connector	Medium	Configuration
4815	SC Duplex	Single-mode fiber	82.5/125 micron
	SC Duplex	Multimode fiber	62.5/125 micron
	RJ-45	Cat 5 copper	UTP
4825	RJ-45	Cat 3, 4 or 5 copper	UTP
4875	SC Duplex	Multimode fiber	62.5/125 micron
	RJ-45	Cat 5 copper	UTP

To connect the adapter to the network, do the following:

1. Attach the appropriate connector to the adapter, as shown in one of the illustrations in Figure 2-2 on page 10.
2. Reconnect the power cable and turn on the machine.
3. The state of the LEDs should be as shown in the table below.

LED	State	Function
Status	Solid Yellow	The board has power.
Link	Off	Driver not installed.

Connecting the Adapter to the Network

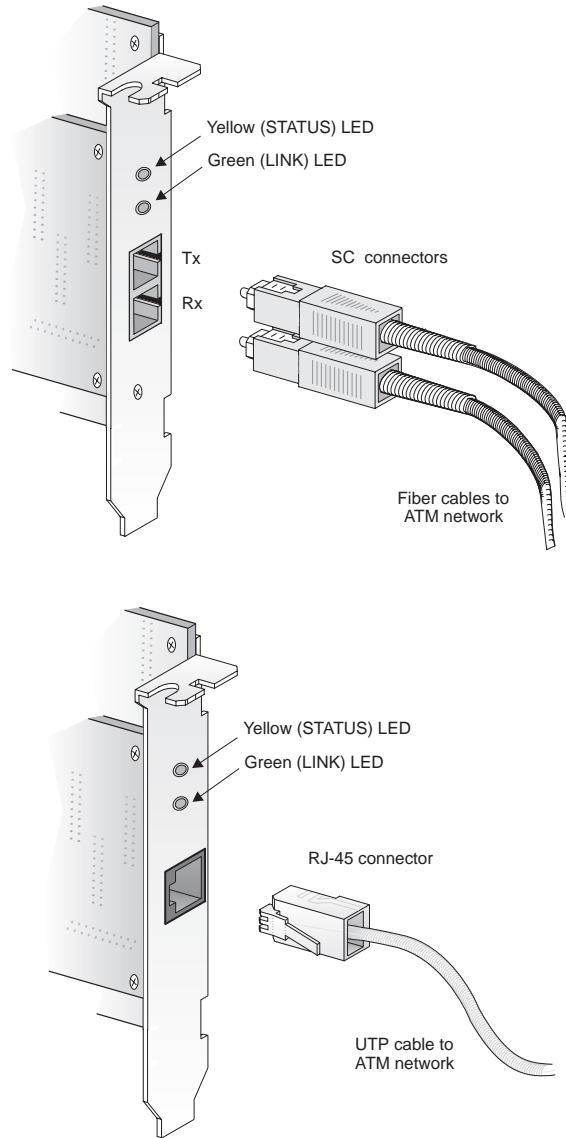
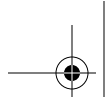
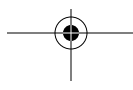
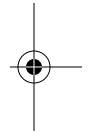

Figure 2-2. Network Connections



Installation of the hardware for EISA ATM adapter is complete.

Next, you need to install the appropriate adapter driver. Both quick installation guides and expanded procedures are available in this users guide.



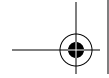

Connecting the Adapter to the Network

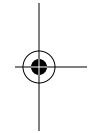

Quick Driver Installation Guides

3

Overview

This chapter contains a brief, one-page installation guide for each driver that supports the EISA ATM adapters. Expanded discussions for Windows NT and NetWare are presented in their respective chapters.

A directory to the guides is as follows:

Driver	Page
Windows NT	14
NetWare Server	18
IRIX	15
HP-UX 9.05/9.07	16
HP-UX 10.10	17

Windows NT

With Windows NT version 3.51 or 4.0 up and running:

1. From the Main Group, open the Program Manager, open the Control Panel, select the **Network** icon.
2. From the Network Settings dialog, select **Add Adapter**.
3. Select **<Other> Requires disk from manufacturer** from the list box in the Add Network Adapter dialog, and select **Continue**.
4. Insert the installation CD-ROM and change the path to **<drv>:\x86_WinNT** where **<drv>** is the drive letter of the CD-ROM.
5. When the Select OEM Option dialog appears, select **OK** to confirm the name of the driver.
The installation may take several minutes.
6. When the Network Settings dialog appears, select **OK**.
7. If TCP/IP is installed on your computer, the TCP/IP Configuration dialog appears.
Enter the IP address, net mask, and so forth for each client which will be enabled with the CellView utility.
8. Select **Don't Restart Now** in the Network Settings Change dialog.
9. See *CellView Utility* on page 57 to configure the clients and services to the network.
10. Restart the machine.

The installation of the driver is complete.

IRIX

1. Configure the IRIX network interface:
 - a. For each client being initialized, add the IP Name and IP Address to the hostname file **/etc/hosts**.
 - b. Add the interface(s) to the kernel by editing the file **/etc/config/netif.options**.
 - c. Create the configuration file for each client.
2. Log in as **root**.
3. Determine whether you need to change the defaults for the installation script, **inatm**.
4. Insert the CD-ROM in the local drive and enter the appropriate command for your operating system.:

```
cd /CDROM/IRIX_5_3
cd /CDROM/IRIX_6_2
```
5. Run the installation script to install the driver.

```
./inatm [option(s)]
```

where **[options(s)]** is the command line options, if needed, as determined in a step 3. If the options are correct, answer **Yes** to the prompt. The installation script runs to completion without additional attention. When complete, answer **Yes** to reboot the system.
6. See *CellView Utility* on page 57 to enable and configure the clients to the network.
7. Automate the signalling for boot-time by adding the appropriate startup and shutdown commands to the **/etc/init.d/network** file.

Installation of the driver for IRIX complete.

HP-UX 9.05/9.07

1. Log in as **root**.
2. Insert the CD-ROM and mount it with the command:

```
mount -F <fstype> <special> <directory>
```
3. As superuser, copy the ATM configuration file to your EISA directory with the command:

```
cp <path>/!INP5000.CFG /etc/eisa
```

where `<path> = cd/cdrom/HP_UX_9_X`.
4. Run the EISA configuration utility by entering the command `add INP5000 <slotnum>` for each Interphase adapter, then reboot the computer.
5. As superuser, install the driver using the command:

```
update -r -s /<path>/INPHID1.tar ""
```

where `<path> = cd/cdrom/HP_UX_9_X`.
The installation may take several minutes. An automatic reboot occurs after the driver is loaded successfully.
6. Configure the network interface for each client by editing the startup script file `/etc/inphid1rc`.
 - a. Look for a set of commented lines relating to the **li** interface similar to:

```
#/etc/ifconfig li0 <netaddr> netmask <netmask> up
```
 - b. Remove the `#` from each line that is going to be configured, and enter the IP address and net mask.
7. Execute the startup script `/etc/inphid1rc`.

See *CellView Utility* on page 57 to enable and configure the clients.

HP-UX 10.10

1. Log in as **root**, insert the CD-ROM and mount it with the command:

```
mount -F <fstype> <special> <directory>
```

2. As superuser, copy the ATM configuration file using,

```
cp <path>/INP5000.CFG \  
  \sbin/lib/eisa/!INP5000.CFG'
```

where <path> = cd/cdrom/HP_UX_10_X.

3. Run the EISA configuration `add INP5000 <slotnum>` for each Interphase adapter, then reboot the computer.

4. As superuser, install the driver using the command:

```
swinstall -x autoreboot=true -s \  
  /cd/cdrom/HP_UX_10_X/INPHID1.tar \*
```

The installation may take several minutes.

5. Configure the network interface for each client by editing the file `/etc/rc.config.d/liconf`.

- a. Look for a set of commented lines similar to:

```
;;INTERFACE_NAME[<x>]=li<x>  
;;IP_ADDRESS[<x>]=  
;;SUBNET_MASK[<x>]=
```

where <x> represents the IP interface number.

- b. Remove the semicolon from each line in the set, and enter the IP address and net mask.

- c. Repeat step **a** and step **b** for all clients being enabled.

6. Execute the startup script `/sbin/init.d/inphid1 start`.

See *CellView Utility* on page 57 to enable and configure the clients.

NetWare Server

With NetWare 3.12, 4.10 or 4.11 up and running on the file server, run the Netware **install** utility and do the following:

1. Select **Driver Options**, select **Configure network drivers**, select **Select an additional driver**, then press **Insert** to install an unlisted driver.
2. Insert the installation CD-ROM and change the path (F3 key) to **<drv>:\Netware** where **<drv>** is the drive letter of the CD-ROM.
3. Select a driver that matches the speed and type of framing for your network.
4. Select **Select/Modify driver parameters & protocols**.
 - a. If you need to add TCP/IP or AppleTalk, select the protocol you wish to enable. If you are installing an Ethernet driver, you can change the frame type from 802.2 by pressing **F3**.
 - b. Edit the value of **Channel** to match the increment number in the box titles.
 - c. Select **Save parameters and load driver** and press **Enter** to accept the random network number.
5. Select **No** to exit the configuration, or select **Yes** to configure another client. If **Yes**, select the same driver for the client and repeat step 4.
6. Add the **load asig** and **load cvconf** commands after the last BIND command in the **autoexec.ncf** file. Restart the server.

See *CellView Utility for NetWare Servers* on page 103 to configure the clients to the network.

Windows NT Driver Installation

4

Overview

This chapter describes the procedures for installing the driver for up to eight adapters in an endstation running Microsoft Windows NT. During installation, four LECs and one IP over ATM client are initialized. One LEC (Client 0) is enabled by default. All remaining clients and LAN services are disabled and can be configured to the network with the CellView utility on 7-57. The driver supports the following features:

- LAN Emulation clients (SVC)
 - Ethernet
 - Token Ring
- LAN Emulation services (LES, BUS and LECS)
 - Ethernet
 - Token Ring
- IP over ATM client (SVC)
- IP over ATM server
- PVC option for each client based on RFC-1483



CAUTION

Your ATM switch must be capable of supporting the UNI 3.0/3.1 signalling standard for SVCs. Some switch vendors allow the mixing of the two standards. Some vendors require that all ports be set to either UNI 3.0 or

Driver Requirements

UNI 3.1. Check your switch documentation for the proper settings. The default setting for the EISA ATM adapter is UNI 3.0.

If any *Read Me First* documentation is in your installation kit, review it before installing the driver. It contains any changes and updates to this users guide since the printing date. Also, check for a **readme** file in the **x86_WinNT** directory of the installation CD-ROM. If you are not thoroughly familiar with ATM networking, read the tutorial *ATM Technology Overview* on page 143.

The basic procedures for installing the ATM driver are:

- Verify driver requirements
- Install the driver
- Configure the IP interface

Driver Requirements

The Windows NT workstation must meet the following minimum requirements:

- Intel x86 CPU running Microsoft Windows NT version 3.51 or 4.0
- CD-ROM drive
- 5 MB of free space on the hard disk
- System memory
 - 20 MB minimum
 - up to 32 MB with the LAN services enabled
- TCP/IP interface (if applicable)

- IP addresses for four LECs and the IP over ATM client
- Subnet mask for each client

Installing the Driver

The driver can be installed prior to installing the adapter(s). Where feasible, however, it is recommended the adapter(s) be installed first.



CAUTION

If an earlier version of a driver is installed on the endstation, you must remove it before proceeding with the new driver. See the section *Removing a Driver* on page 25 for instructions.

To install the driver for Windows NT, do the following:

1. Boot your system under Windows NT.
2. Log in to your Windows NT administrator account.
3. From the Main Group, open the Program Manager, open the Control Panel, and select the Network icon.
4. In the Network Settings dialog, select **Add Adapter**.
5. In the Add Network Adapter dialog, select **<Other> Requires disk from manufacturer** and select **Continue**.
6. Insert the installation CD-ROM.
7. Run the installation script as follows:

Installing the Driver

- a. Change the path to
`<drv>:\x86_WinNT`
 where `<drv>` is the drive letter of the CD-ROM.
- b. When the Select OEM Option dialog appears, select **OK** to confirm the name of the driver.

If you are installing multiple adapters and repeating the installation steps, a message appears advising that a driver of this type is already installed. Select **OK** to continue loading the driver.

The installation may take several minutes. When copying is complete, the dialog in Figure 4-1 appears.

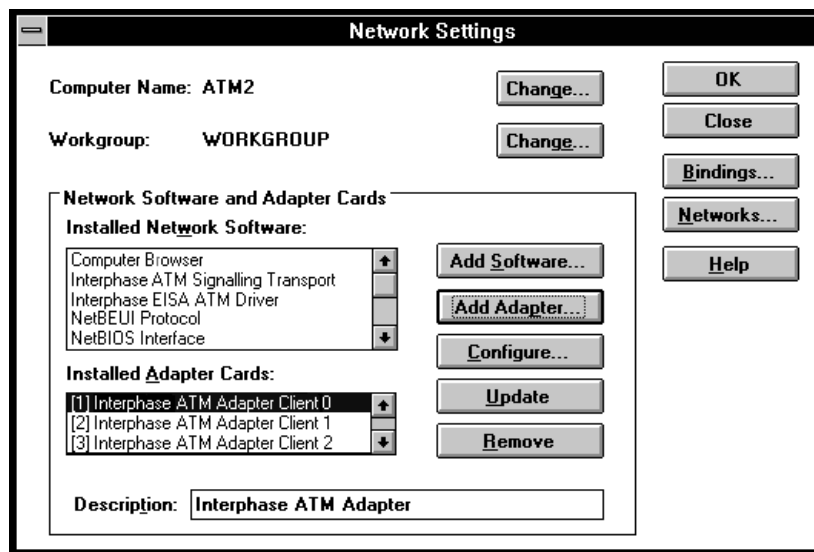

Figure 4-1. Completed Network Settings

Five clients, Client 0 through Client 4, are added to the Installed Adapter Cards list. When repeating the installation for multiple adapters, five more clients of the same name are added to the list. For example, if you

load the driver three times there are three listings for **Interphase ATM Adapter Client 0**, and so forth.

8. Select **OK** in the Network Settings dialog.

Continue the installation with the procedures in the next section.

Configuring the Protocols

When exiting the Network Settings dialog and TCP/IP is installed on your computer, the TCP/IP Configuration dialog appears as shown in Figure 4-2. You must enter an IP address and net mask for all clients before exiting the dialog. If needed, you can enter dummy numbers for those clients which will not be enabled.

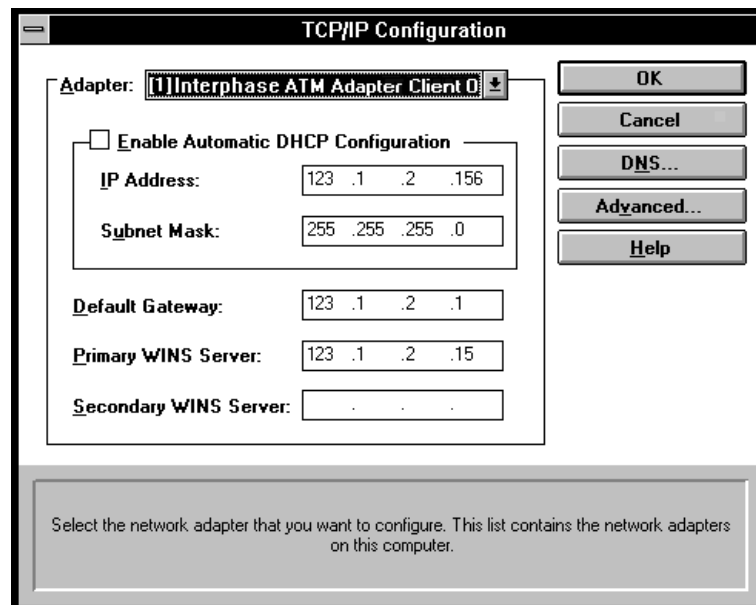

Figure 4-2. TCP/IP Configuration

Configuring the Protocols



NOTE

The IP addresses shown in Figure 4-2 are sample entries only. Use the IP addresses for your network when editing the TCP/IP parameters.

To edit the TCP/IP Configuration dialog, do the following:

1. Select a client to configure in the Adapter list box.

You can configure the clients in any order; however, it is recommended that you work with Client 0 first.

2. Enter the IP Address.

This is the Internet address for the host client. The format is dotted decimal notation in the form *xxx.xxx.xxx.xxx*, where *xxx* ranges from 0 to 254.

3. Enter the Subnet Mask.

This mask is used to partition the IP address into subnets at the local company level.

4. Enter the Default Gateway.

This is normally in the form of an IP address identifying your network's leg from a router or other network device.

5. Enter the IP address of the Primary WINS Server.

This is the address of the primary name server used for looking up the host names of local and connected networks.

6. Enter the IP address of the Secondary WINS Server.

The secondary server (if available) is a backup to the primary name server.

7. Select **OK** when all the clients are configured.
8. Select **Don't Restart Now** in the Network Settings Change dialog.
9. If you have multiple adapters in the machine, go to the Network Settings dialog and repeat the steps in the previous two sections beginning with step 4 on page 21. Up to eight EISA ATM adapters can be installed in the host machine.
10. When all the drivers are loaded, see *CellView Utility* on page 57 to configure the clients to the network.
11. If you wish to verify that the driver is installed and operational, see *Verifying Driver Installation* on page 127.

The installation of the EISA ATM driver is complete.

Removing a Driver

To remove a driver from Windows NT, do the following:

1. From the Main Group, open the Program Manager, open the Control Panel, and select the Network icon.
2. In the Network Settings dialog, Select **Interphase ATM Adapter Client 0** in the Installed Adapter Cards list box.

The NT operating system does not allow you to remove any of the drivers individually. You must select Client 0.

3. Select **Remove**.

Removing a Driver

You are prompted to confirm removal of the adapter.

4. Select **Yes** to remove all the clients and associated drivers.



NOTE

Do not attempt to reinstall the drivers before restarting the computer.

5. Select **OK** in the Network Settings dialog.
6. Select **Restart Now** in the reboot prompt.
7. Exit Windows NT and reboot the computer.

IRIX Driver Installation

5

Overview

This chapter contains the procedures for installing the LAN Emulation (LANE) driver for IRIX version 5.3 or 6.2. The driver is for Switched Virtual Circuits using the User-Network Interface 3.0/3.1 signaling specification. The communication links between nodes are set up and torn down dynamically for each transmission of data.

The driver complies with the ATM Forum LAN Emulation specification version 1.0 which provides broadcast/multicast addressing, allowing you to run legacy LAN (Ethernet, Token Ring, and FDDI) applications and protocols over an ATM network. The driver also supports multiple Emulated LANs (ELANs). A single board can have up to four different MAC addresses and belong to four different ELANs simultaneously.

The Interphase software supports the following:

- Up to eight EISA ATM adapters per system
- Up to four LECs (LAN Emulation Clients) per adapter using both SVC and PVC communications
- One IP over ATM client per adapter using both SVC and PVC communications
- Optional Network Services
 - Up to eight LESs (LAN Emulation Servers) on the same adapter as the LECS
 - One LECS (LAN Emulation Configuration Server) on the same adapter as the LESs
 - One IP over ATM server per adapter

Driver Requirements

During installation of the driver, four LECs (0 – 3) and one IP over ATM client (total of five clients) are assigned to each adapter. At least one client must be fully configured and enabled before running any applications on the network. You are not required to use the other clients.

Driver Requirements

Installing this driver requires a system with the following:

- IRIX 5.3 or 6.2 operating system
- Root password
- 1.0 MB space in `/ (root)` file system
- 6.0 MB space in `/usr` file system
- CD-ROM drive
- IP address, IP name, broadcast address, net mask, for each client to be enabled (maximum of five clients)

In addition, the following information must exist:

- Major device number for the **ia** hardware driver. The default setting is 60.
- Major device number for the **li** software driver. The default setting is 61.

If any Read Me First documentation is in your installation kit, review it before installing the driver. Also, check for a **readme** file in the **IRIX_5_3** or the **IRIX_6_2** directory of the installation CD-ROM. If you are not thoroughly familiar with ATM networking, read the tutorial *ATM Technology Overview* on page 143.

Configuring the Network Interface

It is recommended that the IRIX network interface be configured prior to running the Interphase install script. The configuration procedures in this section are specific to the IRIX operating system and not to the Interphase driver. The instructions are generic in nature, and your particular setup may vary slightly. This users guide assumes the person installing the driver is somewhat familiar with the administration of IRIX networking.

All five clients on each adapter do not have to be activated. You only need to configure the actual clients which are going to be used on the network. Additional clients, if needed, can be configured at a later date without reinstalling the driver. For example, if you are going to use one LEC and the IP over ATM client, only two clients need to be activated at this time.

To configure the IRIX network interface for the clients, do the following:

1. For each client being activated (four LANE and one IP over ATM maximum per adapter), add the <IP name> and <IP address> to the hostname database file **/etc/hosts**.

For example, a client with an IP address of *123.456.789.321* and an associated hostname of *irix-atm* is entered in the file as follows:

```
123.456.789.321 irix-atm
```

2. Add the interface(s) to the kernel by editing the file **/etc/config/netif.options**.

Follow the directions provided in the file.

The mappings used by the ATM driver are as follows:

LECs:

Configuring the Network Interface

*IP interface = (adapter number * 4) + client number*

IP over ATM clients:

IP interface = adapter number + 32

For example,

li0 = adapter 0, LEC 0

li1 = adapter 0, LEC 1

li2 = adapter 0, LEC 2

li3 = adapter 0, LEC 3

li4 = adapter 1, LEC 0

li5 = adapter 1, LEC 1

...

li31 = adapter 7, LEC 3

li32 = adapter 0, IP over ATM client

li33 = adapter 1, IP over ATM client

...

li39 = adapter 7, IP over ATM client

Each client represents an individual entity which must be added to the system. For example, when editing the **/etc/config/netif.options** file, look for blank *if<number>* variables such as:

```
:if<X>name=
:if<X>addr=
```

where *<X>* is the next available interface number.

Set the variables to their network interface values, then uncomment the lines by removing the colon, as shown in the following example:

```
if1name=li0
if1addr=irix-atm
```

where *li0* is from the above list of interface names for clients, and the *irix-atm* name is mapped to an IP address in the **/etc/hosts** file, edited in step 1.

3. Create the interface configuration file.

The system boot procedure performs an **ifconfig** on all network interfaces specified in the **/etc/config/netif.options** file. This config uses command line options contained in the file **/etc/config/ifconfig-<X>.options** where **<X>** is the interface number used in step 2.

For example, to create an ifconfig file for *if1* from the previous step, the file name is **/etc/config/ifconfig-1.options** with the content your network requires, such as:

```
broadcast 123.456.789.0 netmask \
0xffffffff00 up
```

4. Repeat step 1 through step 3 for each network interface to be supported by the LAN emulation driver.

When the network interface is complete for all the clients you want to configure, continue with the next section.

Installing the Driver

The CD-ROM included with the adapter contains all of the files required to install the driver. With the network interface completed as explained in the previous section, install the driver as follows:

1. Log in as **root**.

You must know the current password.

2. Check the available disk space by entering

```
df -k
```

There must be at least 1.0 MB of free space in the **/root** file system, and at least 6.0 MB of free space in the **/usr** partition.

*Installing the Driver***3.** Insert the CD-ROM in the local drive.

There are two, separate software packages for the EISA ATM adapter. One package is for the IRIX 5.3 operating system, and the other package is for IRIX version 6.2. The packages are located in their respective directories, **IRIX_5_3** and **IRIX_6_2**, on the CD-ROM. If you are not sure which operating system is installed on your machine, enter the command,

```
uname -sr
```

4. Determine whether you need to change the defaults for the installation script, **inatm**. The variables are as follows:

Variable	Command	Description	Default
BINDIR	-b (<i>path</i>)	Directory for binaries	<i>/usr/sbin</i>
CFGDIR	-c (<i>path</i>)	Directory for config files	<i>/etc/config</i>
MANDIR	-m (<i>path</i>)	Directory for man pages	<i>/usr/share/catman/a_man/cat1</i>
IAMAJ	-i (<i>num</i>)	Major device number for ia hardware driver	60
LIMAG	-l (<i>num</i>)	Major device number for li software driver	61
IUSR	-u usr	Install 'user'	root
IGRP	-g grp	Install 'group'	sys

You can change the defaults in either of two ways:

- Permanently change the value of a variable by editing the **inatm** installation script
- Temporarily override the default for one or more variables by using command line options

For example, if you want to change the install script permanently to place the binary utility files in **/bin** instead of the default **/usr/sbin**, you have to edit the **BINDIR** variable in the install script to read:

```
BINDIR = /bin
```

To override the same default as a one-time substitution during the current installation, use the command line option

```
inatm -b /bin
```

Additional options are separated with a space. For example, if a value of 80 is needed for the **IAMAJ** variable, in addition to the **BINDIR** setting above, the multiple commands would be

```
inatm -b /bin -i 80
```

5. Insert the CD-ROM in the local drive and enter one of the following:

If IRIX version 5.3 is installed on your machine, enter

```
cd /CDROM/IRIX_5_3
```

If IRIX version 6.2 is installed on your machine, enter

```
cd /CDROM/IRIX_6_2
```

6. Run the installation script to install the driver.

```
./inatm [option(s)]
```

where **[options(s)]** is the command line options, if needed, as explained in a step 4.

You are prompted with the message:

Installing the Driver

OK to use parameters: yes/no

7. Answer **yes** to the prompt. Otherwise, enter **no** and repeat this procedure beginning with step 4 on 32.

If a EISA ATM driver is already installed on your machine, the installation script detects it, and prompts you to remove it. The installation script executes, and displays messages as it begins and completes its tasks.

When the installation is complete, the script displays the following:

```
The driver has now been installed and
the kernel reconfigured. However, no
ATM clients or services have been
enabled yet. After rebooting the new
kernel, use
CellView(/usr/sbin/cellview) to
fully configure, maintain, and
monitor your ATM environment.
```

```
You must reboot to use the new
driver/kernel
```

```
Reboot now (yes/no)?
```

8. Enter **yes**.
9. Use the Interphase CellView utility (*CellView Utility* on page 57) to enable and configure the clients. If the LECS and the LESs are to be on this workstation, you must enable their dialogs with the **Global** option from the main CellView dialog.

When all items are enabled and configured, exit the CellView utility and continue the installation with the procedures in the next section.



CAUTION

All configuration data for CellView is stored in the file `/etc/atm/cvconf` for which an on-line man page is available. You are strongly encouraged to use the CellView utility to modify the parameters instead of editing them manually. If the parameters get out of sync, the driver may not work properly.

If for some reason the CellView utility will not run on your system, there are command-line utilities (such as `lec`, `les`, and `lecs`) which can modify the software currently running. However, these commands do not change the permanent settings in the `cvconf` file. The effects of these commands are lost when the machine is turned off or restarted. Whatever the case, do not mix the running of command-line and CellView utilities. Use one method consistently or unpredictable results may occur.

Automating Startup and Shutdown

The UNI signalling application must be started after the hardware device drivers have been loaded by the kernel. The application can be started manually after bootup, or the start procedure can be automated using the startup script provided with the installation software. You can add both startup and shutdown commands to the `/etc/init.d/network` file.



NOTE

The paths to the `lec`, `sigd_start`, and `iadump` files in the following sections must match the paths specified during the driver installation (the `-b` command line option). The paths to `lec`, `signald`, and `iadump`, if

changed from the install script's default (/usr/sbin/), must be changed in the following examples, and also in the scripts: sigd_start and sigd_stop.

To automate the startup and shutdown, edit the **/etc/init.d/network** file as follows:

1. Set the LANE client startup by adding the following script ahead of the double semicolon (;) that terminates the case **start** statement:

```
# ATM/LEC startup
if $IS_ON atmcv && test -x /usr/sbin/cvconf;then
/usr/sbin/cvconf
fi
```

The **inatm** install script creates the **/etc/config/atmcv** file with the contents: **on**. This file is used by the **\$IS_ON** test created above. To disable configuration of the LANE clients at boot time, change the contents of the file to **off**. This change mandates that you configure each client manually after every boot or reboot.

2. Set the Signald startup by adding the following command lines at the end of the case **start** statement:

```
# ATM/SIGD startup
if $IS_ON atmsigd && test -x /usr/sbin/sigd_start; then
/usr/sbin/sigd_start
fi
```

The **inatm** install script creates the **/etc/config/atmsigd** file with the contents: **on**. This file is used by the **\$IS_ON** test created above. To disable startup of the signaling application at boot time, change the contents of the file to **off**. This change mandates that you start the signald application manually after every boot or reboot.

3. Shut down the system.

Most systems do not provide a hardware reset during a reboot. If the hardware is not reset during a reboot, the board remains active, and the kernel PANICs upon receipt of the first receive packet.

You can provide this much-needed hardware reset by adding the following script ahead of the double semicolon (;;) that terminates the case **stop** statement:

```
# ATM/LANE shutdown
if $IS_ON atmdown && test -x /usr/sbin/iadump; then
  /usr/sbin/iadump shutdown
fi
```



CAUTION

If you do not add a shutdown command and the *Kernel Panic* occurs, the only way to bring the workstation back up is to turn the power off, and then back on again.

The lane install script creates the `/etc/config/atmdown` file with the contents: **on**. This file is used by the `$IS_ON` test created above. To disable this hardware reset during shutdown, change the contents of the file to **off**. This change mandates that you reset the hardware manually prior to a reboot (or requires a power cycle before booting).

4. Reboot the system.

A reboot is required to install, configure, and activate the adapter and driver. To reboot the system, do the following:

- a. Click the desktop manager's System Restart function, or enter

Setting the European STM-1 mode

/etc/reboot

- b.** Watch the console for messages and/or errors starting with IASG.
 - c.** Notification and error messages related to the EISA ATM adapter display beginning with the string IASG as the system reboots. These messages are copied to the system log file **/var/adm/SYSLOG**, where you can access them if you need to.
- 5.** If you wish to verify that the driver is installed and operational, see *Verifying Driver Installation* on page 127.

The installation and configuration of the IRIX driver for the EISA ATM adapter is complete.

Setting the European STM-1 mode

To configure the adapter for European STM-1 mode edit the **/var/sysgen/master.d/li** file as follows:

- 1.** Locate the line

```
int ia_stm = 0;
```

- 2.** Set the *ia_stm* variable to 1 instead of zero:

```
int ia_stm = 1;
```

- 3.** Run the command,

```
/etc/autoconfig
```

- 4.** Reboot the system.

HP-UX Driver Installation

6

Overview

This chapter explains how to install the driver for up to eight EISA ATM adapters in an endstation running HP-UX[®] version 9.05, 9.07 or 10.10. During installation of the driver, up to four LECs and one IP over ATM client can be initialized per adapter.

The driver supports the following features:

- LAN Emulation clients (SVC)
 - Ethernet[®]
 - Token Ring
- LAN Emulation services (LES, BUS and LECS)
 - Ethernet
 - Token Ring
- IP over ATM client (SVC)
- IP over ATM server
- PVC option for each client based on RFC-1483



CAUTION

Your ATM switch must be capable of supporting the UNI 3.0/3.1 signalling standard for SVCs. Some switch vendors allow the mixing of the two standards. Some vendors require that all ports be set to either UNI 3.0 or UNI 3.1. Check your switch documentation for the proper settings. The default setting for the EISA ATM adapter is UNI 3.0.

Driver Requirements

There are two drivers for HP-UX on the Interphase installation CD-ROM. A common driver and all utility files for versions 9.05 and 9.07 are located in the **HP_UX_9_X** directory. The files for version 10.10 are located in the **HP_UX_10_X** directory. The two drivers are not cross-compatible and must be installed to the appropriate operating system. If you are not sure which operating system is installed on your machine, enter the command,

```
uname -a
```

If any *Read Me First* documentation is in your installation kit, review it before installing the driver. It contains any changes and updates to this users guide since the printing date. Also, check for a **readme** file for the driver being installed in the **HP_UX_9_X** or the **HP_UX_10_X** directory on the installation CD-ROM. If you are not thoroughly familiar with ATM networking, read the tutorial *ATM Technology Overview* on page 143.

Driver Requirements

The endstation must meet the following minimum requirements:

- HP[®] 9000-725 PA-RISC[®] workstation
- HP-UX operating system version 9.05, 9.07, or 10.10
- System memory:
 - 16 MB minimum
 - 24 MB minimum with multiple clients and servers enabled
- CD-ROM drive
- A hard disk with free space consisting of:
 - 5MB in the **/root** partition

- 1MB in the **/usr** partition
- Superuser login
- IP address, broadcast address, net mask, and **ifconfig** options for each client being initialized

The driver can be installed prior to installing the adapter(s). Where feasible, however, it is recommended the adapter(s) be installed first.

Do one of the following:

- If you are installing the driver for version 10.10, see *Installing the Driver for HP-UX 10.10* on page 48.
- Otherwise, begin the installation of the driver for version 9.05 or 9.07 with the procedures in the next section.

Installing the Driver for HP-UX 9.05/9.07

The driver and all utility files are located in the **HP_UX_9_X** directory on the Interphase installation CD-ROM. You can extract the files to a temporary directory on your hard disk, or you may install the driver and utilities direct from the CD. In either case, the original files are not altered during the installation process. The procedures in this section explain how to install the software direct from the CD-ROM.

To install the EISA ATM driver for HP-UX version 9.05 or 9.07, do the following:

1. Log in as **root**.
2. Check the available disk space by entering:
df
3. If needed, check for an existing installation of the driver by entering:

Installing the Driver for HP-UX 9.05/9.07

netstat -i

All active and inactive **li** interfaces appear on the screen. If any Interphase ATM drivers are in the list, remove them as explained in *Removing a Driver from HP-UX 9.05/9.07* on page 47.

4. Insert the CD-ROM in the local drive and mount it with the command:

```
mount -F <fstype> <special> <directory>
```

For example,

```
mount -F cdfs /dev/dsk/c201d2s0 /cdrom
```

5. As superuser, copy the ATM configuration file to your EISA directory with the command [all on one line including the backslash and exclamation point (!)] as shown below:

```
cp cdrom/HP_UX_9_X/INP5000.CFG (space)
   /etc/eisa/\\!INP5000.CFG
```

6. Run the EISA configuration utility as follows:

The EISA configuration procedures are specific to the HP-UX operating system and not to the Interphase driver. The instructions are generic in nature, and your particular setup may vary slightly.

- a. Enter the command:

```
show
```

to see if any boards are currently installed. The output should be similar to the example in Figure 6-1.

Slot	CFG File	Contents
2		** Empty**
3	!INP5000	Interphase 4800 EISA-PCI Bridge

Figure 6-1. Slot Numbers for Adapters

This example shows one Interphase EISA ATM adapter installed in slot #3.

b. Enter the command:

```
add INP5000 <slotnum>
```

for each Interphase adapter where *<slotnum>* represents the number of the physical slot which contains, or will contain, the adapter.

See the HP documentation for a description of slot numbers. Use the `?` command if you have any questions about the `eisa_config` utility.

c. Reboot the computer.

7. As superuser, install the Interphase ATM driver using the command:

```
update -r -s /<path>/INPHID1.tar ""
```

where *<path>* = `/cdrom/HP_UX_9_X`.

The installation may take several minutes, and should run to completion without any further attention. An automatic reboot occurs after the driver is loaded successfully.

Continue the installation of the driver with the steps in the next section.

Configuring the Network Interface

There are five clients (four LECs and one IP over ATM client) associated with each EISA ATM adapter. All five clients do not have to be activated. You only need to configure the actual clients which are going to be used on the network. Additional clients, if needed, can be configured at a later date without reinstalling the driver. For example, if you are going to use only one LEC and the IP over ATM client for an adapter, only two clients need to be activated for that adapter at this time.

You will need the following information to activate each client.

- Network IP address
- Net mask



CAUTION

When other IP nodes reside on the host system (Ethernet for example), the IP address used for each ATM client must be a totally separate network segment. If the same segment is used, then routing and broadcast problems will occur as the network layer will assume that both devices are physically on the same segment. Also, do not assign more than one ATM client for an adapter to the same network segment.

The data to automatically configure the driver at boot time is stored in the script file `/etc/inphid1rc`. You must edit this file and add the correct `li` interface for each client being activated.

1. Use your favorite text editor and open the file `/etc/inphid1rc`.

2. Look for a set of commented lines relating to the li<x> interface similar to:

```
#/etc/ifconfig li0 <netaddr> netmask <netmask> up  
#/etc/ifconfig li1 <netaddr> netmask <netmask> up  
#/etc/ifconfig li2 <netaddr> netmask <netmask> up  
#/etc/ifconfig li3 <netaddr> netmask <netmask> up
```

where <x> represents the IP interface number for a client, which ranges from 0 – 31 for the LECs and 32 – 39 for the IP over ATM clients. The mappings used by the ATM driver are as follows:

LECs:

$$IP\ interface = (adapter\ number * 4) + client\ number$$

IP over ATM clients:

$$IP\ interface = adapter\ number + 32$$

For example,

li0 = adapter 0, LEC 0

li1 = adapter 0, LEC 1

li2 = adapter 0, LEC 2

li3 = adapter 0, LEC 3

li4 = adapter 1, LEC 0

li5 = adapter 1, LEC 1

...

li31 = adapter 7, LEC 3

li32 = adapter 0, IP over ATM client

li33 = adapter 1, IP over ATM client

...

li39 = adapter 7, IP over ATM client

- a. Remove the comment character (#) from each line that is going to be configured.
- b. Enter the IP address and net mask for each client.

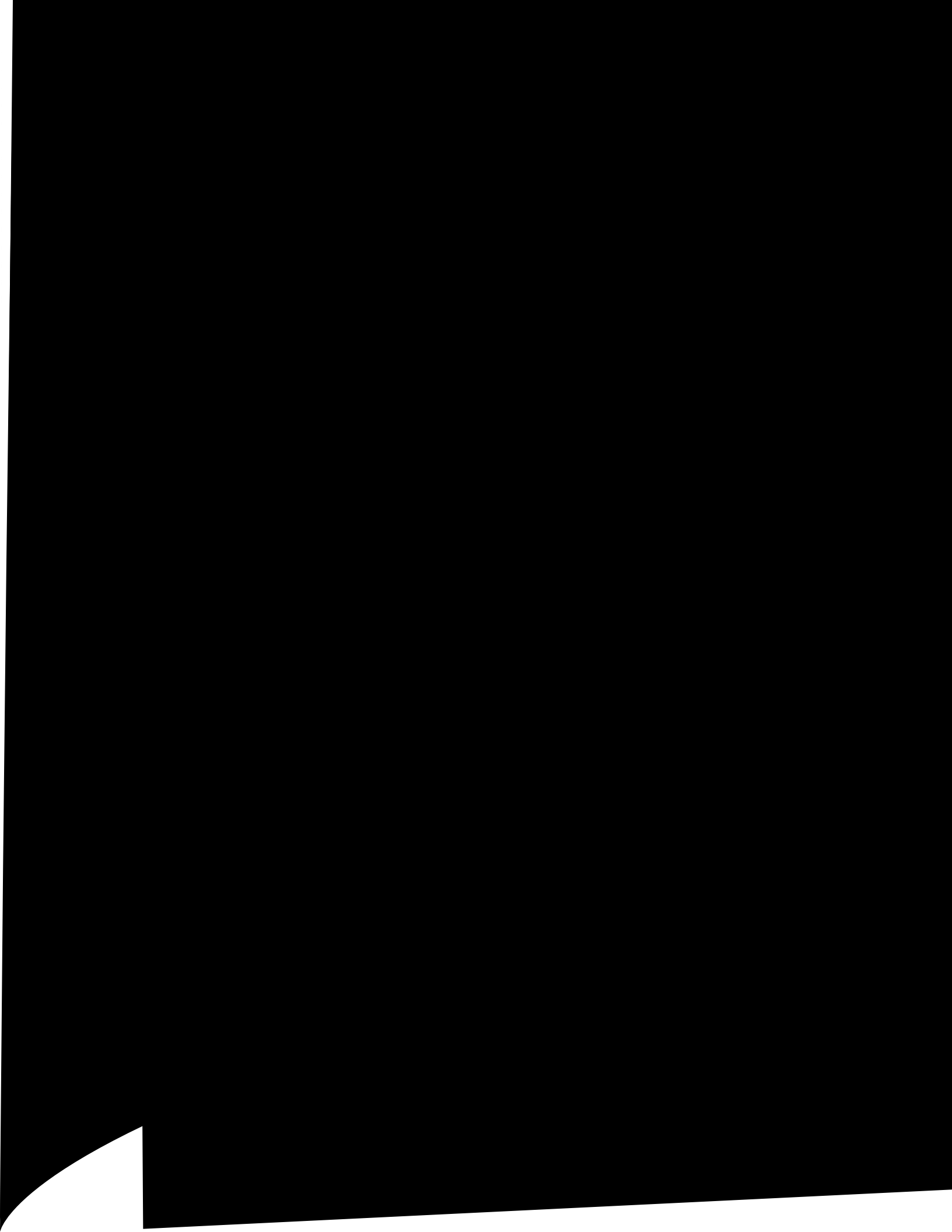

restarted. Whatever the case, do not mix the running of command-line and CellView utilities. Use one method consistently or unpredictable results may occur.

5. When complete, reboot the machine.
6. If you wish to verify that the driver is installed and operational, see *Verifying Driver Installation* on page 127.

The installation and configuration of the driver for HP-UX version 9.05 or 9.07 is complete.

Removing a Driver from HP-UX 9.05/9.07

To remove an Interphase EISA ATM driver,

1. Disable the LANE and IP over ATM clients with the *CellView Utility* on page 57.
2. Run the shutdown script:

```
/etc/shutdown.d/inphid1stop
```

to disconnect the interfaces (li0, li1, and so forth).
3. Remove the software filesets with the commands:

```
rmfn -1 INPHID1-RUN  
rmfn -1 INPHID1-MAN
```
4. Remove the EISA ATM driver from the kernel and rebuild it as follows:
 - a. Run **SAM**
 - b. Select **Kernel Configuration**
 - c. Select **Drivers**

Installing the Driver for HP-UX 10.10

- d. Select **Actions**
 - e. Select **Create a New Kernel**
 - f. Select **Move Kernel into place and continue shutdown**
5. If removing the Interphase adapter(s) from the machine,
- a. Run the EISA utility with the command:

```
eisa_config
```
 - b. Enter the command:

```
remove <slotnum>
```

for each Interphase adapter where *<slotnum>* represents the number of the physical slot which contains the adapter.

If needed, see the HP documentation for a description of slot numbers. Use the **?** command if you have any questions about the **eisa_config** utility.

The EISA ATM driver is now removed.

Installing the Driver for HP-UX 10.10

The driver and all utility files are located in the **HP_UX_10_X** directory on the Interphase installation CD-ROM. You can extract the files to a temporary directory on your hard disk, or you may install the driver and utilities direct from the CD. In either case, the original files are not altered during the installation process. The procedures in this section explain how to install the software direct from the CD-ROM.

To install the EISA ATM driver for HP-UX version 10.10, do the following:

1. Log in as **root**.

2. Check the available disk space by entering:

```
df
```

3. If needed, check for an existing installation of the driver by entering:

```
netstat -i
```

All active and inactive **li** interfaces appear on the screen. If any Interphase ATM drivers are in the list, remove them as explained in *Removing a Driver from HP-UX 10.10* on page 54.

4. Insert the CD-ROM in the local drive and mount it with the command:

```
mount -F <fstype> <special> <directory>
```

For example,

```
mount -F cdfs /dev/dsk/c0t4d0 /cdrom
```

5. As superuser, copy the ATM configuration file to your EISA directory with the command [all on one line including the adjacent backslash and exclamation point (!)] as shown below:

```
cp cdrom/HP_UX_10_X/INP5000.CFG (space)
  /sbin/lib/eisa/!\INP5000.CFG
```

6. Run the EISA configuration utility as follows:

The EISA configuration procedures are specific to the HP-UX operating system and not to the Interphase driver. The instructions are generic in nature, and your particular setup may vary slightly.

- a. Enter the command,

```
show
```

Installing the Driver for HP-UX 10.10

to see if any boards are currently installed. The output should be similar to the example in Figure 6-2.

Slot	CFG File	Contents
2		** Empty **
3	!INP5000	Interphase 4800 EISA-PCI Bridge

Figure 6-2. Slot Numbers for Adapters

This example shows one Interphase EISA ATM adapter installed in slot #3.

b. Enter the command:

```
add INP5000 <slotnum>
```

for each Interphase adapter where *<slotnum>* represents the number of the physical slot which contains, or will contain, the adapter.

See the HP documentation for a description of slot numbers. Use the `?` command if you have any questions about the `eisa_config` utility.

c. Reboot the computer.

7. As superuser, install the Interphase ATM driver using the command (all on one line ending with `*`):

```
swinstall -x autoreboot=true -s (space)
\ /cdrom/HP_UX_10_X/INPHID1.tar \*
```

The installation may take several minutes, and should run to completion without any further attention. An automatic reboot occurs after the driver is loaded successfully.

Continue the installation of the driver with the steps in the next section.

Configuring the Network Interface

There are five clients (four LECs and one IP over ATM client) associated with each EISA ATM adapter. All five clients do not have to be activated. You only need to configure the actual clients which are going to be used on the network. Additional clients, if needed, can be configured at a later date without reinstalling the driver. For example, if you are going to use only one LEC and the IP over ATM client for an adapter, only two clients need to be activated for that adapter at this time.

You will need the following information to activate each client.

- Network IP address
- Net mask



CAUTION

When other IP nodes reside on the host system (Ethernet for example), the IP address used for each ATM client must be a totally separate network segment. If the same segment is used, then routing and broadcast problems will occur as the network layer will assume that both devices are physically on the same segment. Also, do not assign more than one ATM client for an adapter to the same network segment.

The data to automatically configure the driver at boot time is stored in the file **liconf**. You must edit this file and add the correct **li** interface for each client being activated as follows:

Installing the Driver for HP-UX 10.10

1. Use your favorite text editor and open the file **/etc/rc.config.d/liconf**.
2. Look for a set of commented lines (with leading semicolon) relating to the interface similar to:

```
;INTERFACE_NAME[ <x> ] =li<x>
;IP_ADDRESS[ <x> ] =
;SUBNET_MASK[ <x> ]=
```

where <x> represents the IP interface number for a client which ranges from 0 – 31 for the LECs and 32 – 39 for the IP over ATM clients. The mappings used by the ATM driver are as follows:

LECs:

*IP interface = (adapter number * 4) + client number*

IP over ATM clients:

IP interface = adapter number + 32

For example,

```
li0 = adapter 0, LEC 0
li1 = adapter 0, LEC 1
li2 = adapter 0, LEC 2
li3 = adapter 0, LEC 3
li4 = adapter 1, LEC 0
li5 = adapter 1, LEC 1
...
li31 = adapter 7, LEC 3
li32 = adapter 0, IP over ATM client
li33 = adapter 1, IP over ATM client
...
li39 = adapter 7, IP over ATM client
```

- a. Remove the semicolon from each line in the set.
- b. Enter the IP address and net mask for the client.

For example if you are activating the first two LECs and a IP over ATM client on Adapter 0, the entries should be similar to:

```
INTERFACE_NAME[0] =li0
IP_ADDRESS[0] = 123.234.100.55
SUBNET_MASK[0]= 255.255.255.0

INTERFACE_NAME[1] =li1
IP_ADDRESS[1] = 123.235.100.55
SUBNET_MASK[1]= 255.255.255.0

INTERFACE_NAME[32] =li32
IP_ADDRESS[32] = 123.236.100.55
SUBNET_MASK[32]= 255.255.255.0
```

c. Save the changes and close the file.

3. Execute the startup script with the command:

```
/sbin/init.d/inphid1 start
```

4. Use the Interphase *CellView Utility* on page 57 to enable and configure the clients. If the LECs and the LESs are to be on this workstation, you must enable their dialogs with the **Global** option from the main CellView dialog.



CAUTION

All configuration data for CellView is stored in the file */etc/atm/cvconf* for which an on-line man page is available. You are strongly encouraged to use the CellView utility to modify the parameters instead of editing them manually. If the parameters get out of sync, the driver may not work properly.

If for some reason the CellView utility will not run on your system, there are command-line utilities (such as *lec*, *les*, and *lecs*) which can modify the software currently

Installing the Driver for HP-UX 10.10

running. However, these commands do not change the permanent settings in the *cvconf* file. The effects of these commands are lost when the machine is turned off or restarted. Whatever the case, do not mix the running of command-line and CellView utilities. Use one method consistently or unpredictable results may occur.

5. When complete, reboot the machine.
6. If you wish to verify that the driver is installed and operational, see *Verifying Driver Installation* on page 127.

The installation and configuration of the driver for HP-UX version 10.10 is complete.

Removing a Driver from HP-UX 10.10

To remove an Interphase EISA ATM driver from HP-UX version 10.10:

1. Log in as **root**.
2. Disable all LANE and IP over ATM interfaces (clients and servers) with the *CellView Utility* on page 57.
3. Stop signalling with the command:

```
/sbin/init.d/inphid1 stop
```
4. Remove the EISA ATM driver from the kernel and rebuild it as follows:
 - a. Run **SAM**
 - b. Select **Kernel Configuration**
 - c. Select **Drivers**

- d. Select the **li** driver
- e. Select **Actions**
- f. Select **Remove Driver from Kernel**
- g. Select **Actions**
- h. Select **Create a new Kernel**
- i. Select **Move Kernel into place and continue shutdown**

Do not become alarmed when, at boot time, there is an error when starting the Interphase software. This error will be resolved in the next step.

5. Execute the command:

```
swremove INPHID1
```

This removes the Interphase EISA ATM driver.

6. If removing the Interphase adapter(s) from the machine,

- a. Run the EISA utility with the command:

```
eisa_config
```

- b. Enter the command:

```
remove <slotnum>
```

for each Interphase adapter where *<slotnum>* represents the number of the physical slot which contains the adapter.

If needed, see the HP documentation for a description of slot numbers. Use the **?** command if you have any questions about the **eisa_config** utility.

7. To remove the config file for the Interphase adapter(s), execute the command (with single quotes and the exclamation point as shown):

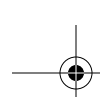

Installing the Driver for HP-UX 10.10

```
rm ` /sbin/lib/eisa/!INP5000.CFG`
```

8. Reboot the computer.

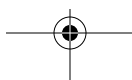

CellView Utility

7

Overview

CellView is a cross-platform, GUI utility which is used to configure the clients and services to the network. The example dialogs presented in this chapter may vary slightly from what actually appears on your screen. However, the options and capabilities within each dialog remain the same. For example, you may have a button to enable a particular feature when the example is showing a check box.

CellView provides the following features:

- Configure signalling parameters
- Enable, disable, and configure up to four LECs and one IP over ATM client per adapter
- Set up PVC communications with other endstations
- Enable, disable, and configure up to eight LESs and one IP over ATM ARP server per adapter
- Enable, disable, and configure one LECS per adapter
- Display operating statistics for
 - SONET, signalling, and cell level activity
 - ATM Adaptation Layer 5 (AAL5) activity
 - LEC membership and activity
 - IP over ATM activity
 - LECS and LES activity
- Set CellView parameters for displaying and updating the dialogs.

the features disabled.
CellView and make the changes to your network. At minimum, the network must be up and fully configured before job. Do not forget to configure your ATM switch for communications (SVC, PVC, or b

The edits made with CellView are stored on your hard disk. The changes do not take effect until the device reads this file and reconfigures itself. When running in a Windows-based operating systems, for example, you must exit the utility and restart the machine in order for the device to recognize the changes. In UNIX-based systems, the changes are dynamic upon exiting the Setup routines, except for signalling which can be restarted from the command line.



NOTE

The dialogs in the Statistics group are included in the CellView utility to assist you and Interphase personnel in the event a problem occurs with the adapter or with your ATM network. Detail interpretation of the statistics is beyond the scope of this manual. However, limited procedures for using the dialogs are included in the troubleshooting sections of this Users Guide.

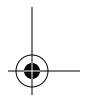
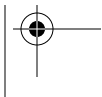

Getting Started

The procedures in this chapter assume that at least one adapter is installed in the endstation, the driver is installed for your operating system, and the machine has been rebooted prior to running the CellView utility. If not, see the appropriate chapter in this users guide or the appropriate addendum and install the necessary hardware or software.

The start-up sequence or command for the CellView utility depends upon the operating system in use. For example the Windows format from Microsoft requires a sequence of commands for selecting a CellView icon. The UNIX-based systems require a single command only. The start-up sequence or command for each operating system is shown in Table 7-1 on page 60. Upon launching CellView, the main dialog appears, as shown in Figure 7-1. The exception to the contents of this dialog is for Windows NT when configuring PCI ATM adapters. In this case, the main dialog contains an additional selection box for changing the PCI Interrupt value.

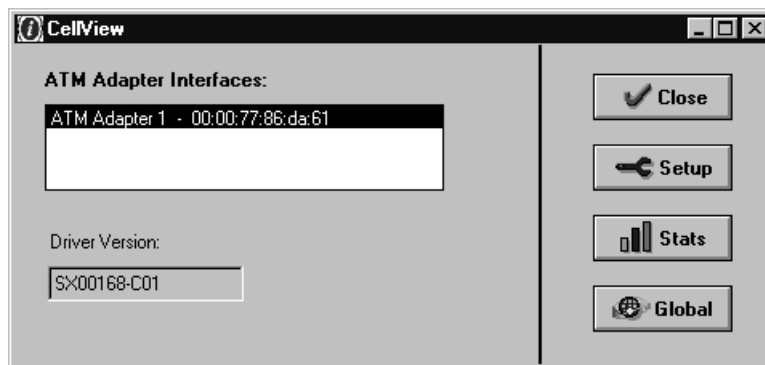

Figure 7-1. Main CellView Dialog

*Getting Started***Table 7-1. Start-up Sequence or Commands for CellView**

Operating System	Version	Sequence or Command
AIX	4.1.2 or 4.1.4	Enter the command <code>cellview</code>
HP-UX	9.07 or 10.10	Enter the command <code>cellview</code>
IRIX	5.3, 6.2, 6.3, or 6.4	Add to your path <code>/usr/sbin/</code> Enter the command <code>cellview</code>
SCO	OpenServer 5.0 or later	Add to your path <code>/etc/atm/bin</code> Enter the command <code>cellview</code>
Solaris	2.5 or later	Enter the command <code>cellview</code>
UnixWare	2.01, 2.1, or 2.1.1	Enter the command <code>cellview</code>
Windows 95	All	Select Start Select Settings Select Control Panel Select the CellView icon
Windows NT	3.51	Go to the Main Group Open the Program Manager Open the Control Panel Select the CellView icon
	4.0	Select Start Select Settings Select Control Panel Select the CellView icon

The main CellView dialog lists the adapter(s) installed in your computer and contains the buttons for navigating the utility. All subsequent dialogs are *child* dialogs which can be displayed in multiple configurations on your computer screen. The contents of each dialog are tied to the adapter being highlighted in the ATM Adapter Interfaces box.

Selections from the main CellView dialog are:

Selection	Description
Interrupt	(Windows NT only) Contains the PCI interrupt value for the adapter being highlighted in the ATM Adapter Interfaces box. A default setting of AutoDetect is recommended. If you do not want the operating system to pick an interrupt level automatically, you have the option to set a specific interrupt level. If the driver fails to recognize the adapter with the AutoDetect setting, you may need to select an interrupt level that coincides with your system BIOS.
Close	Exits the CellView utility.
Setup	Contains tabbed dialogs to configure: Signalling LECs (4 maximum per adapter) LESSs (8 maximum on same adapter as LECS) LECS (on same adapter as the LESSs) IP over ATM client and ARP server
Stats	Contains tabbed dialogs to display the status of: Signalling AAL5 LECs LESSs LECS IP over ATM client and server
Global	Contains tabbed dialogs to configure: Parameters to control Setup and Stats dialogs Connection limits for endstations (display only) Debug tools for tracking of API, Signalling, and ILMI

Setup

One setting that affects the dialogs in the Setup and Stats routines is **Enable Advanced Settings** (see *Application* on page 82). This setting controls whether or not the LECS and LES tabs appear for editing and viewing. If Enable Advanced Settings is set to **OFF** (default), the tabs do not appear.

Setup

Up to four LECs and one IP over ATM client can be enabled per adapter. Dialogs are also provided for enabling an LECS and up to eight LESs for the ATM network. No particular order is required for configuring the clients and services. If you are going to enable the LECS and the LESs, you should configure these first before configuring the clients.

In UNIX-based systems the machine does not have to be restarted for the edits to take effect. Any change to the Setup dialogs, except UNI Signalling, are dynamic upon exiting Setup. In IRIX operating systems, signalling can be restarted with the command `sigd_start`. Otherwise, use the command `restart_sigald`.

A directory for the tabbed dialogs under Setup is as follows:

Dialog	Page
UNI Signalling	63
LAN Emulation Clients	65
IP over ATM Client and Server	70
ELAN Services	73
LAN Emulation Configuration Server	74
LAN Emulation Servers	76

UNI Signalling

The drivers are designed to operate with the UNI 3.0/3.1 signalling specification using SVC communications. Changes to the Signalling dialog do not take effect until the machine is rebooted, or restarted from the command line in UNIX-based systems.

Path

From the main CellView dialog select **Setup**. The dialog for Signalling appears, as shown in Figure 7-2.

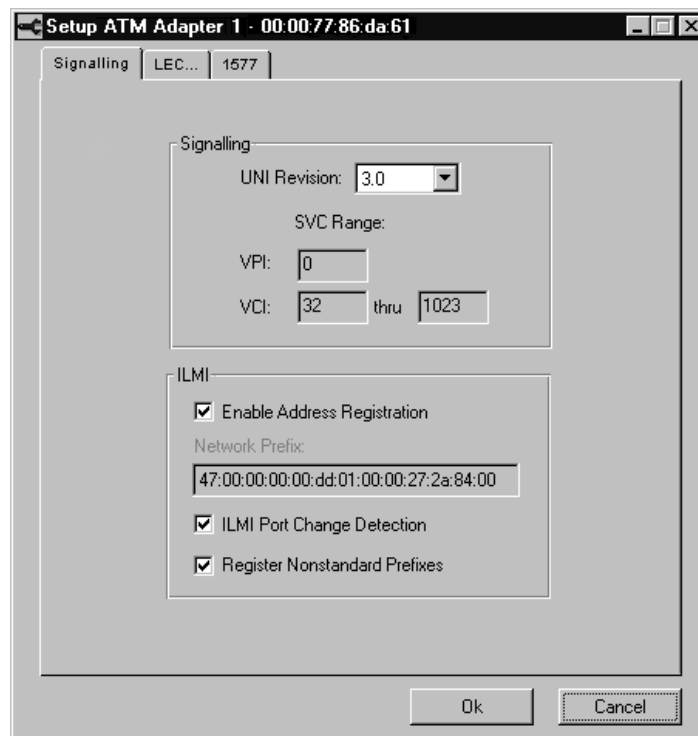

Figure 7-2. CellView Signalling Setup

Setup

UNI Revision

Some switch vendors allow the mixing of signalling versions on the same switch and some vendors do not. If the signalling cannot be mixed, all ports must be set to either UNI 3.0 or UNI 3.1. Check your switch documentation for the proper setting.

VPI (Virtual Path Identifier)

(Display Only) A one-byte field in the ATM cell header which, when combined with the VCI (see below), makes up an ATM address. At present, only VPI 0 is supported.

VCI (Virtual Circuit Identifier)

(Display Only) The range of VCIs available to the driver is shown in the VCI fields. In the sample dialog of Figure 7-2 on page 63, circuits 0 – 31 are reserved for system communications. Circuits 32 – 1023 are available for station-to-station traffic.

Enable Address Registration

When enabled, the adapter acquires its network prefix at bootup from the switch. The feature should be disabled if your switch does not support address registration. You will have to obtain the 13-byte prefix from the switch and enter the address manually in the Network Prefix field.

ILMI Port Change Detection

When enabled, the adapter polls the ATM switch every 30 seconds, advising that it is up and running. At bootup, the switch adds the host station to the active list. If the host station is turned off, polling stops and the switch removes the host from its active stations list. Disable this setting if your switch does not support ILMI polling.

Register Nonstandard Prefixes

When enabled, the ATM Forum's well-known address for the LECS is registered with the switch by the ILMI. The prefix in the well-known address is usually different than the ATM prefix for the adapter. Some switches may not support the registration of different prefixes through a single port. Disable this setting if your switch does not support mixed prefixes.

LAN Emulation Clients

The driver allows up to five clients to be enabled at a time per adapter. You must have at least one LEC or an IP over ATM client enabled and fully configured before running any applications on the network. The other clients are optional and can be enabled at anytime. Each client has a tabbed dialog for their configuration. It contains the parameters to establish communications with an LECS at bootup, or can be set to contact an LES directly. Controls are also available to set up PVC links with other endstations.

Path

From the main CellView dialog select **Setup**, then select the **LEC** tab. The configuration dialog appears, as shown in Figure 7-3 on page 66.

Enable

When disabled, all settings in the dialog are ignored by the driver. If using PVCs only, the client must be enabled in order for the driver to recognize the client.

PVC Only

Use this feature to set up PVC communications without enabling the LEC activity. You need only to configure the L3MTU Size and the PVC Table as described in later sections.

Setup

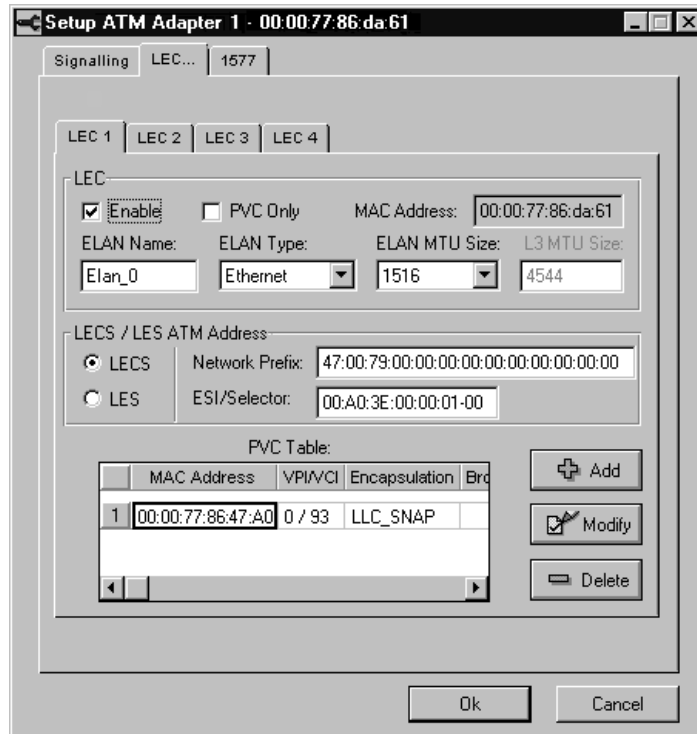

Figure 7-3. CellView LEC Setup

MAC Address

(Display Only) The text field contains the MAC address of the client. Client 1 is assigned the base address for the adapter. The remaining clients use an increment of the base for their MAC address.



NOTE

In Token Ring applications, the MAC Address is displayed in non-canonical format.

ELAN Name

This is the network name of the emulated LAN that you prefer the client to join. Some configuration servers require a name while others do not. The Interphase LECS and LESs do not require a name unless Strict ELAN Name is enabled on the LES, or you need to differentiate between two or more LESs with the same MTU size and ELAN type. Refer to your server documentation for the exact requirements. The setup of the Interphase servers begins on page 74.

ELAN Type

All nodes on the same logical subnet must use the same frame type. If an edge device to a legacy LAN is part of the ELAN, the frame type for that edge device must be used.

ELAN MTU Size

As with the ELAN Type, all nodes that are part of the same logical subnet must use the same MTU size. The client uses this entry when making a request to join an LES. The MTU returned to the client is equal to or less than the requested value.

Recommended settings for ELAN MTU Size are as follows:

ELAN with Ethernet edge device: **1516**
ELAN with Token Ring edge device: **4544**
ELAN with ATM endstations only: **9234**

Setup

L3MTU Size

If set to a value other than zero, it forces the MTU size of the client to a specific value instead of the value returned by the LANE server. **If the client is in PVC Only mode (no LANE services), L3MTU Size must be set to the IP MTU of the network.**

In situations where the MTU is not based on the MAC layer, **L3MTU** should be set to the actual IP MTU of the network. For example if the ELAN MTU Size of a Token Ring network is 4544, but the IP MTU is 2048, the **L3MTU Size must be set to 2048.**

LECS/LES ATM Address

There are two option buttons for setting the mode of contact at bootup.

- **LECS:** Contacts the LECS with the 20-byte ATM address in the Network Prefix and ESI/Selector fields. The default address is the ATM Forum's well-known address.
- **LES:** Uses the 20-byte address in the ATM address fields to contact an LES directly.

PVC Table

A PVC configuration table is provided in the LEC dialogs to set permanent links between a client and other endstations on the network. A 6-byte MAC address and a VCI number are associated with each PVC. Packets from the upper layers whose destination MAC address matches an address in the PVC table are transmitted on that PVC.

Changes to the table take effect immediately and do not require a reboot of the computer. All PVCs have to be set up and torn down manually. The MAC address of the target

station must be mapped to a VCI in the local host. A similar setup is required at the target station using the MAC address of the local client. In PVC connections, do not forget that the two endstations must be linked together manually through the ATM switch(s).

The PVC Table, as shown in Figure 7-3 on page 66, is used to configure the permanent connections. Three buttons are used to manipulate the table:

- **Add:** Appends and saves a new entry to the table.
- **Modify:** Changes and saves an existing entry.
- **Delete:** Removes the highlighted entry from the table.

When using Add or Modify, the dialog in Figure 7-4 appears:

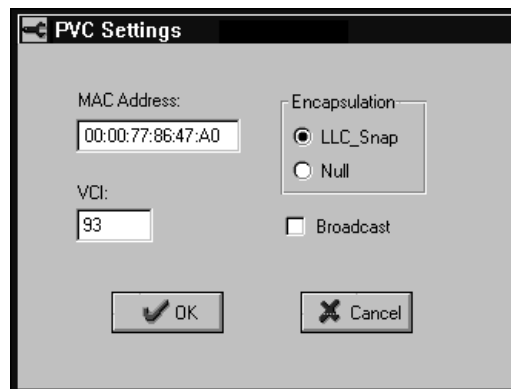

Figure 7-4. PVC Settings for LECs

MAC Address is the 6-byte address of the target station. The address should be entered in the natural format for the ELAN. If Token Ring for example, the address is entered in non-canonical form.

Setup

VCI is the circuit number the client will use to communicate with the target. In most cases, the range is 32 – 1023. If needed, see the Setup dialog for Signalling (Figure 7-2 on page 63) to obtain the range of VCIs available to the driver. The VPI is set to a value of zero in the driver and cannot be edited.

Encapsulation offers a selection for either LLC_SNAP or NULL. Both the host and the target must use the same encapsulation method.

Broadcast, when enabled, sets the entry as a Broadcast PVC. All broadcast/multicast packets from the upper layers are transmitted on this PVC. A maximum of 16 PVCs can be enabled as a Broadcast PVC.

IP over ATM Client and Server

This client conforms to the RFC-1577 specification using IP over ATM where no multicast or broadcast services are available. A PVC Table is available for setting up permanent links with other endstations. You can also set the adapter as the ARP server for the network.

Path

From the CellView main dialog select **Setup**, then select the **1577** tab. The configuration dialog appears, as shown in Figure 7-5 on page 71.

Enable

When disabled, all settings in the dialog are ignored by the driver. If using PVCs only, the client must be enabled in order for the driver to recognize the client.

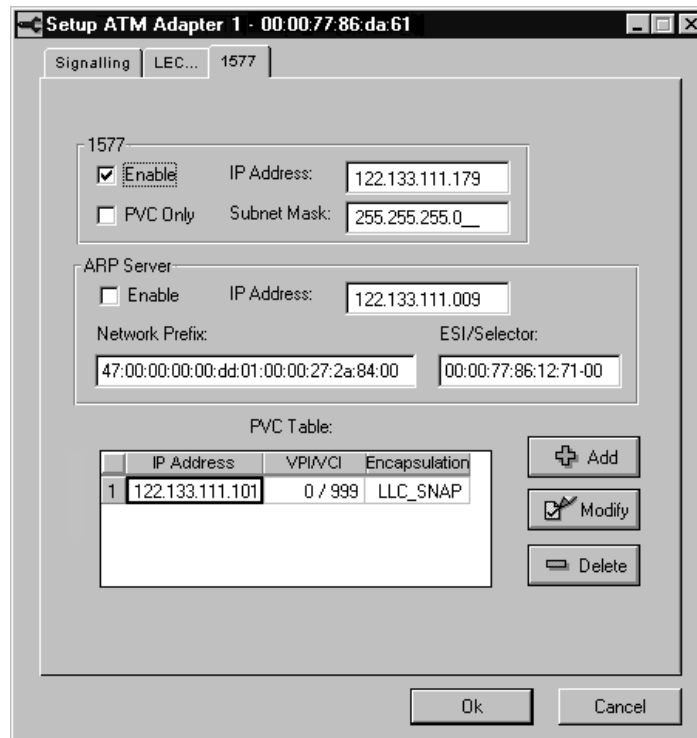

Figure 7-5. CellView IP over ATM Setup

PVC Only

Use this feature to set up PVC communications without enabling the SVC activity. You need only to configure the PVC Table as described in a later section.

IP Address and Subnet Mask

When enabled, the IP address and subnet mask for the client (configured during the installation of the driver) are loaded automatically in the IP Address and Subnet Mask fields, respectively.

Setup

ARP Server—Enable

Enables the host adapter as the ARP server for your IP over ATM network.

ARP Server—IP Address

If the host adapter is not the ARP server, you must enter the IP address of the ARP server located elsewhere in the network.

ARP Server—Network Prefix and ESI/Selector

If the host adapter is not the ARP server, the IP over ATM driver must know the ATM address of the ARP server. When the system is powered up, a call is placed to the ARP server with the ATM address in these two fields.

PVC Table

A PVC table, as shown in Figure 7-5 on page 71, is provided to set permanent connections between the local client and other stations in the IP over ATM subnet. The IP address of the target station must be mapped to a VCI in the local host. A similar setup is required at the target station using the IP address of the local client. The changes take effect immediately and do not require a reboot of the computer.

Three buttons are used to manipulate the table as follows:

- **Add:** Appends and saves a new entry to the table.
- **Modify:** Changes and saves an existing entry.
- **Delete:** Removes the highlighted entry from the table.

When using Add or Modify, the dialog in Figure 7-6 on page 73 appears. Descriptions of the controls in the PVC Settings dialog are as follows:

IP Address is the decimal address of the target station.

VCI is the circuit number the client will use to communicate with the target. In most cases, the range is 32 – 1023. If needed, see the Setup dialog for Signalling (Figure 7-2 on page 63) to obtain the range of VCIs available to the driver. The VPI is set to a value of zero in the driver and cannot be edited.

Encapsulation offers a selection for either LLC_SNAP or NULL. Both the host and the target must be set to use the same encapsulation method.

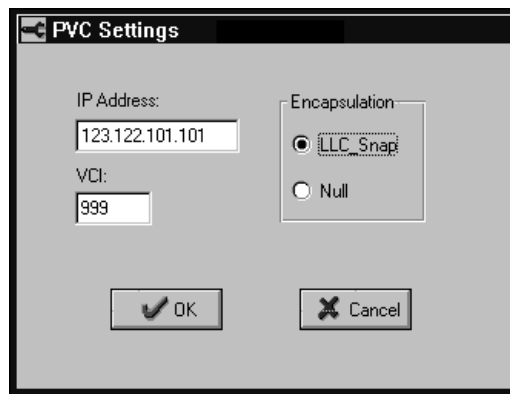

Figure 7-6. PVC Settings for IP over ATM

ELAN Services

In order to communicate on an ATM network, an LEC must join an emulated LAN which consist of a group of endstations that communicate among themselves with the same MTU size, the same frame format, and the same broadcast/multicast services. The central server for this ELAN is the LES. The management of which LEC joins which LES is handled by the LECS. This section contains the instructions for setting up the LECS and up to eight LESs. The LECS and the LESs must reside on the same ATM adapter. They cannot communicate with each other across the network.

Setup

LAN Emulation Configuration Server

The LECS provides a central point of contact on the network for each LEC at boot time. The client sends the LECS a request for the type of ELAN it wants to join. The LECS responds with the current ATM address and the configuration parameters of the appropriate LES.

Path

With the **Enable Advanced Settings** turned on (see *Application* on page 82), select **Setup** from the main CellView dialog then select the LECS tab. The configuration dialog for the LECS appears, as shown in Figure 7-7 on page 75.

Enable

When disabled, all settings in the dialog and all permanent mappings of the clients to specific LESs are ignored by the driver.

Use Well Known Address

When enabled, the ATM Forum's well-known address is loaded to the Network Prefix and ESI/Selector fields. The address appears as an overlay of gray characters and cannot be edited. When disabled, the Network Prefix and ESI/Selector fields can be edited to the ATM address of your choice.

Default MTU Sizes

If the configuration request from an LEC does not include the MTU size, the LEC is assigned to an LES that is using the value in the Default MTU Sizes field, depending upon the ELAN type requested. If the ELAN type is not included in the request from the client, the setting in the Default ELAN Type group is assigned to the LEC as well as the corresponding value in the Default MTU Sizes group.

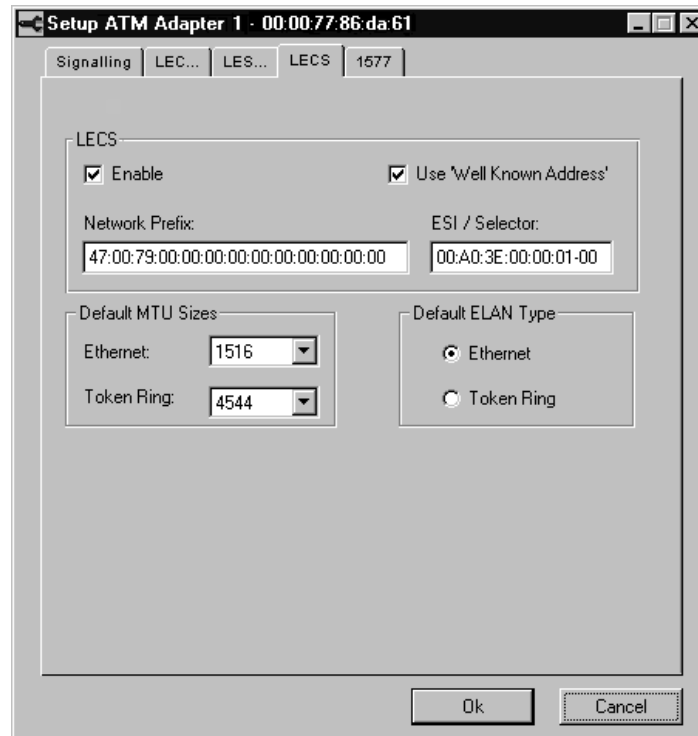

Figure 7-7. CellView LECS Setup

Default ELAN Type

As with the MTU size above, some vendors may not require the ELAN type to be included in the initial requests to the LECS. If not included, the LECS attempts to assign the client to an LES which matches the Default ELAN Type and using an MTU size equal to or less than the size requested. When the MTU size is omitted in the client's request, the corresponding value in the Default MTU Sizes is used.

Setup

LAN Emulation Servers

The LES is a central server in the ELAN which provides address registration, address resolution, and broadcast services for all its members. When an LEC joins an LES, the MAC-ATM relationship of the client is registered with the server. The LES maintains a running account of these addresses to resolve queries from the ELAN members.

The connection between the LES and each LEC is a permanent, open connection as long as the client is up and running. The LES maintains a table containing information about each client and uses this table to provide address resolution services to the ELAN. When an endstation is disconnected or turned off, the LES removes the client(s) from the table automatically. Relocating an endstation is a matter of physically moving the hardware to a new location and connecting it to the same or another ATM switch. At bootup, the client(s) rejoin their previous LES with a new ATM address.

Path

With the Enable Advanced Settings turned on (see *Application* on page 82), select **Setup** from the main CellView dialog then select the LES tab. The configuration dialog for the LESs appears, as shown in Figure 7-8 on page 77.

Enable

When disabled, all settings in the dialog are ignored by the driver.

ELAN Name

This is the network name of the emulated LAN for which the LES is providing services. It is not required in order for an LEC to join the group. If the ELAN Name box in the Strict group is enabled, the name in the LEC request has to match (case sensitive) the name in the text field.

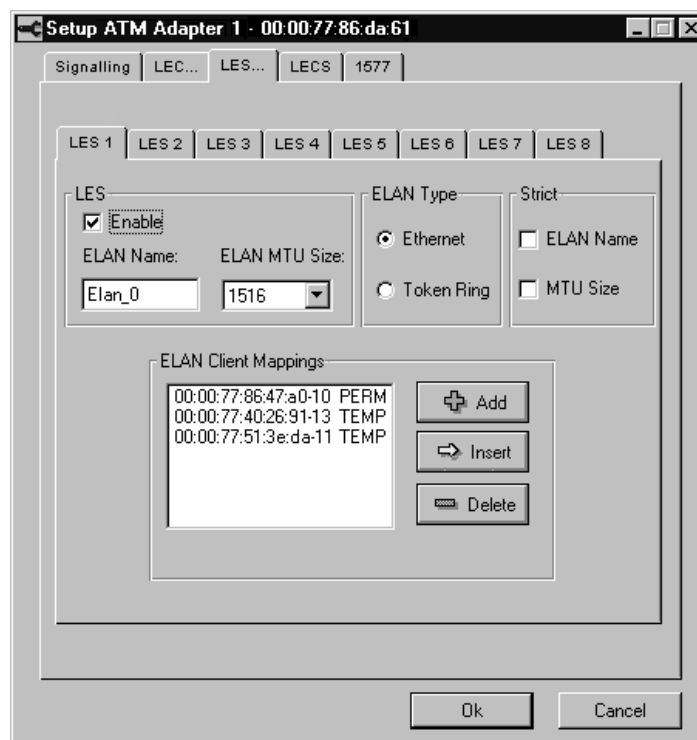

Figure 7-8. CellView LES Setup

ELAN MTU Size

This is the MTU size for the ELAN. Recommended settings are as follows:

Setup

ELAN with Ethernet edge device: **1516**
ELAN with Token Ring edge device: **4544**
ELAN with ATM endstations only: **9234**

If the MTU Size in the Strict group is enabled, the request from the LEC must match the ELAN MTU Size; otherwise, the server will not allow the LEC to join the group.

ELAN Type

Specifies the type of framing used for all communications between endstations. If an edge device to a legacy LAN is part of the ELAN, the frame type must be set to interface with that edge device.

Strict

Specifies whether or not the request coming from the LEC has to match (case sensitive) the entries in the ELAN Name and ELAN MTU Size fields.

ELAN Client Mappings

Displays the ESI/Selector value for each LEC currently assigned to the LES. There are two classifications for the clients:

- **PERM:** At every bootup, the client is assigned automatically to this LES by the LECS regardless of the client's join request.
- **TEMP:** The client is temporarily assigned at boot time to this LES using the settings in the LEC's Setup dialog. The client may or may not be assigned to this LES the next time it attempts to join the network.

The PERM listings are obtained from a table maintained by the LECS. When the LECS is enabled, the PERM status of a client is checked each time the client attempts to join the network, regardless if the client is set to contact the LECS or set to contact an LES directly.

Clients can be added to or deleted from the LES using the buttons located adjacent to the ELAN Client Mappings display box. There are two ways to add a client to an LES. If the client is currently up and running on another ELAN, the **Insert** button allows you to move a client which is up and running on another ELAN. If the client is not up and running, you must use the **Add** button to enter the ESI/Selector value of the client. In both cases the client is permanently assigned to the LES.

The functions of the buttons in the ELAN Client Mappings dialog are:

Add

The dialog in Figure 7-9 is used to enter the ESI/Selector value for a client. If you are not familiar with the structure of this address, see *ATM Address* on page 4.

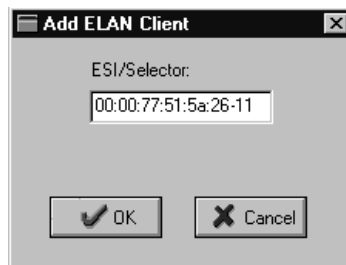

Figure 7-9. Add Permanent Clients to an LES

Setup

When **OK** is selected, a PERM status is appended to the ESI/Selector and the new entry is added to the LES's mapping table. Make sure the client is not permanently assigned to another LES. An entry in the Add ELAN Client dialog does not remove the client from the other LES. A configuration conflict will most likely occur the next time the client attempts to join the network. A client can have only one PERM assignment.

Adding a client that is temporarily assigned to another LES is acceptable. The client is assigned automatically to the new LES by the LECS the next time the client attempts to join the network.

Insert

The dialog in Figure 7-10 is used to move a client from another LES to the LES being configured. The display box contains a listing of all permanent and temporary clients assigned to the other seven LESs.

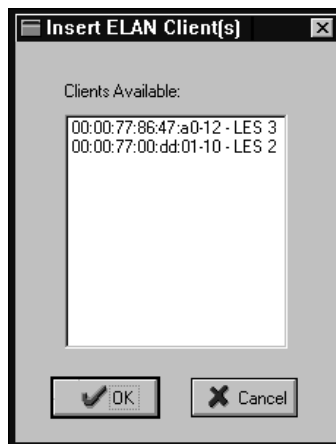

Figure 7-10. Insert Permanent Clients to an LES

To move one or more clients to the LES being configured, highlight the clients of choice and select **OK**. The clients are removed from the other servers, a PERM status is appended to the address of each selection, and the ESI/Selector values are added to the LES's client mapping table.

Delete

To remove a client from the LES, highlight the client or clients to be removed and select **Delete**. If the client is a PERM entry, it is deleted from the PERM table. Once removed from the table, the client immediately attempts to rejoin the network using the settings in its LEC Setup dialog. If the client has a TEMP status when deleted, it will most likely be assigned back to the same LES unless its LEC Setup parameters have changed since the last start up.

Statistics

The display dialogs in the Statistics group are for troubleshooting purposes only. They are included in the CellView utility to assist you and Interphase personnel in the event a problem occurs with the adapter or with your ATM network. Detail interpretation of the principles and applications that support the statistics are beyond the scope of this manual. However, limited procedures for using the dialogs are included in the troubleshooting sections of this Users Guide. CellView can only gather operating statistics for local Interphase clients and servers. It cannot gather statistics from switches or from other endstations. If the LECS and LESs are located on a local adapter, the **Enable Advanced Settings** (see *Application* on page 82) must be enabled in order to see the statistics for the servers.

Global Settings

These routines control the parameters of CellView which operate above the adapter level, mainly the refresh rate used to display the statistics and whether or not the LECS and LES tabs are visible to the user. A restart of the endstation is not required for these settings to take effect.

A directory for the tabbed dialogs under Global is as follows:

Dialog	Page
Application	82
Connections	83
Debugging.....	84

Application

Controls the display settings for the Setup and Statistics routines of CellView.

Path

From the main CellView dialog select **Global**. The Application tab appears, as shown in Figure 7-11 on page 83.

Stat Refresh Rate

Controls the update or refresh rate in milliseconds of the data fields in the Statistics dialogs.

Enable Advanced Settings

When enabled, activates the tabs for the LECS and the LES in the Setup and Statistics dialogs. This setting does not affect the enable/disable condition of the ELAN servers. They can be hidden from view but remain accessible to the drivers.

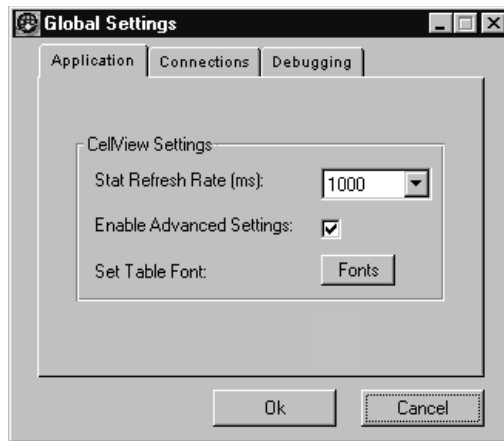

Figure 7-11. CellView Global Application

Connections

Displays the configuration guidelines for all endstations on the ATM network. These settings cannot be edited or changed. They are preset within the drivers.

Path

From the main CellView dialog select **Global**, then select the Connections tab. The dialog in Figure 7-12 on page 84 appears.

Pt-to-Pt

The maximum number of switched and permanent connections allowed at any one time with other endstations.

Global Settings

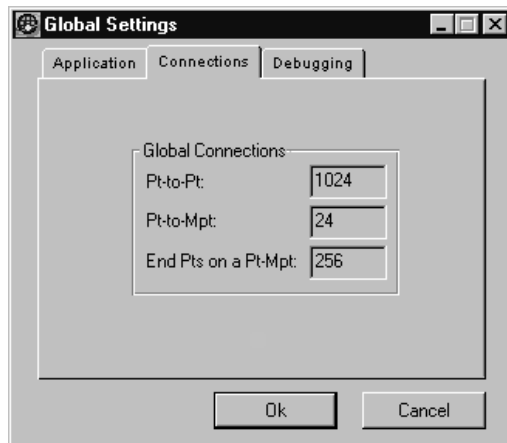

Figure 7-12. CellView Global Connections

Pt-to-Mpt

The maximum number of permanent connections allowed at any one time with the ELAN servers and daemons.

End Pts on a Pt-Mpt

The maximum number of endstations that can be attached to a BUS at any one time.

Debugging

The debug options are used as a troubleshooting aid for the adapter. If you experience difficulty in establishing connections with other network nodes, enabling one or more of the debug options produces messages from various modules to assist in isolating the problem. The messages are loaded to the event viewer or to the systems log of your operating system. Be sure to disable the options when debugging is complete.

Path

From the main CellView dialog select **Global**, then select the Debugging tab. The dialog in Figure 7-13 appears.



Figure 7-13. CellView Global Debugging

API

When enabled, tracks the lower level functions of the Application Program Interface. These are the routines used by the applications software to manage or obtain system resources.

Signalling

When enabled, tracks all communications between the host and the signalling daemon in the switch.

ILMI

When enabled, tracks the protocol used to monitor traffic between the ATM switch and the endstations, including address registration activity.

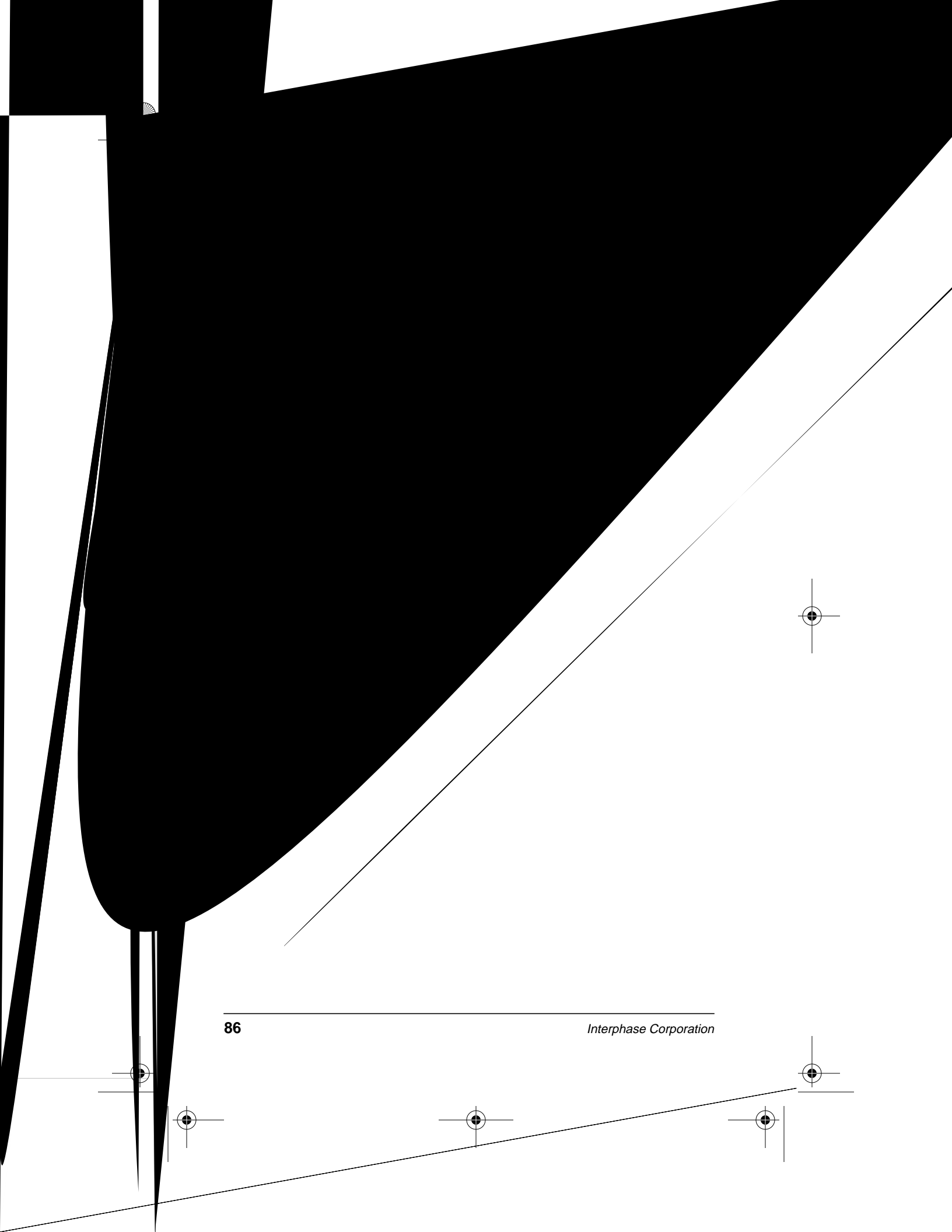

NetWare Server Driver Installation

8

Overview

This chapter contains the procedures for installing the EISA ATM driver on file servers running Novell NetWare. During installation, up to four clients can be assigned to the adapter. One of these clients can be set as an IP over ATM client (based on RFC-1577), or all four clients can be set as LECs. After installation, the clients and LAN services are configured to your network with the Interphase CellView utility for NetWare servers.

If any *Read Me First* documentation is in your installation kit, read it before installing the driver. It contains any changes and updates to this users guide since the printing date. Also, check for a **readme** file in the **Netware** directory on the installation CD-ROM. If you are not thoroughly familiar with ATM networking, read the tutorial *ATM Technology Overview* on page 143.

The basic steps for installing this driver are:

1. Verify the driver requirements.
2. Install the driver.
3. Initialize the clients.
4. Configure the AUTOEXEC.NCF file.
5. Add drivers for additional adapters (if applicable).

Driver Requirements

Driver Requirements

The NetWare file server must meet the following minimum requirements:

- Intel x86 CPU file server running Novell NetWare version 3.12, 4.10, or 4.11
- CD-ROM drive
- 2 MB of free space on the hard disk
- System memory
 - 20 MB minimum
 - up to 32 MB with multiple clients and servers enabled
- TCP/IP interface (if applicable)
 - IP address for each enabled client
 - IP mask

Installing the Driver

The driver can be installed prior to installing the adapter(s). Where feasible, however, it is recommended that you install the adapter(s) first.



CAUTION

If an earlier version of an Interphase PCI ATM adapter driver is installed on the server, you must remove it before proceeding with the new driver. See the section *Removing a Driver* on page 102 for instructions.



NOTE

If TCP/IP is not installed on the server and one or more of the LECs are to use this protocol, or one of the clients is to be an IP over ATM client, you should install TCP/IP on the server before installing the EISA ATM driver.

To install the driver, do the following:

1. With the file server up and running, enter the comand:
`load install`
2. When the Installation Options dialog appears, select **Driver Options**, and then select **Configure network drivers**.
3. In the Additional Driver Actions dialog, select **Select an additional driver**.

The Select A Driver dialog appears. If this is your first installation of the driver, it does not appear in the list.

4. If the driver you want to install does not appear, press **Insert**.

A system prompt appears for changing the installation path.

5. Insert the Interphase installation CD-ROM.
6. Press **F3** and set the path to `<drv>:\Netware` (where `<drv>` is the drive letter of the CD-ROM), and press **Enter**.

The contents of the **Netware** directory appear in a dialog as shown in Figure 8-1 on page 90.

Installing the Driver

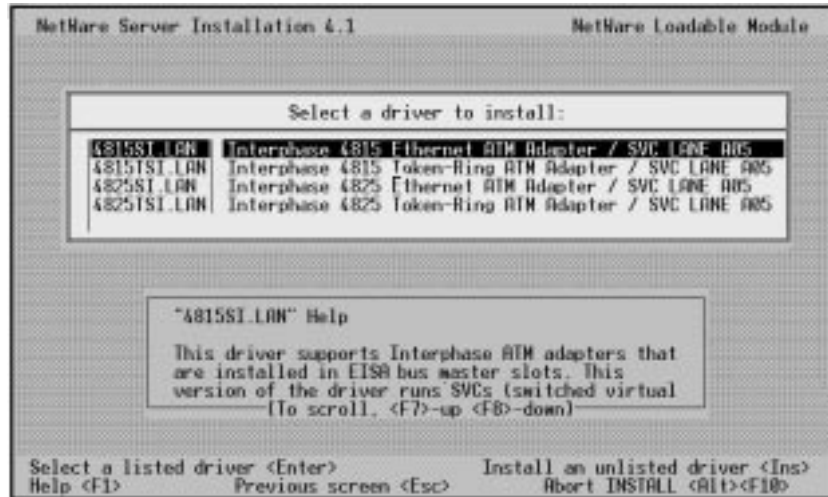

Figure 8-1. Selecting a Driver

7. Select the driver that matches the speed of the adapter and the type of framing for the network.



CAUTION

Ethernet and Token Ring drivers cannot be mixed on the same machine. You must use the same frame type for all channels on all adapters installed in the NetWare server.

The particulars for each driver are:

Driver	Adapter	Frame Type
4815SI.LAN	155 Mbps (4815 or 4875)	Ethernet
4815TSI.LAN	155 Mbps (4815 or 4875)	Token Ring
4825SI.LAN	25 Mbps (4825)	Ethernet
4825TSI.LAN	25 Mbps (4825)	Token Ring

8. Confirm the name of the driver and select **Yes.**

The driver files are copied to the NetWare server.

Continue the driver installation with the procedure in the next section.

Configuring Protocols and Parameters

After the driver files are copied to the NetWare server, as initiated in the previous section, a dialog appears as shown in Figure 8-2. The driver names, located in the box titles, contain the increment of the client being configured. If this is the second installation of the driver, the titles read 4815SI_2 for Client 2, and so forth.

Configuring Protocols and Parameters

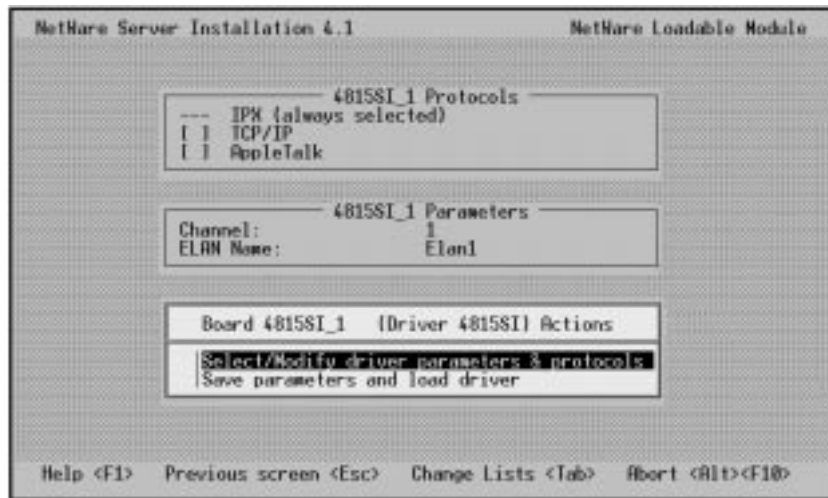

Figure 8-2. Protocols/Parameters Configuration

Do the following:

1. Select **Select/Modify driver parameters & protocols** at the bottom of the dialog.

TCP/IP in the Protocols box is highlighted.

If this LEC is to use TCP/IP or this client is to be an IP over ATM client, you must add the protocol to the client with the next step.

2. If you need to add TCP/IP or AppleTalk, do the following:

- a. Select the protocol you want to enable.

When selecting the TCP/IP option, a dialog appears for entering the IP interface.

IP Address: The Internet address for the client is entered in decimal notation of the form *xxx.xxx.xxx.xxx*, where *xxx* ranges from 0 to 254.

- IP Mask:** The most commonly used mask is ff.ff.ff.0 (hex) or 255.255.255.0 (decimal notation).
- b.** Press **F10** to save and exit the TCP/IP dialog.
 - 3.** If you are loading an Ethernet driver and need to change the frame type from its default of 802.2, press **F3**.
 - a.** In the Frame Type List dialog, select a frame type.
 - b.** Press **F10** to exit.
 - 4.** If the value of **Channel** in the Parameters box does not match the increment number in the box titles, change the Channel value to match the client number.
 - a.** Use the arrow keys to highlight the Channel number in the Parameters box, and press **Enter**.

A dialog appears for setting the channel number.
 - b.** Select the number that matches the client number in the box titles.
 - 5.** Highlight **ELAN Name** and enter the name of the LAN for which this client is to provide NetWare services.
 - 6.** When you are finished configuring the protocols and parameters, press **Esc** to move the highlight to the bottom box and select **Save parameters and load driver**.

A dialog appears containing a random network number for binding the IPX protocol to the driver.
 - 7.** Press **Enter** to accept the binding number.

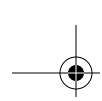

NOTE

It is recommended that you initialize all four clients on the adapter. Disabled clients use minimal resources compared to the tasks of initializing clients at some later date.

8. When the prompt appears for loading the driver for an additional channel, **do one of the following:**
 - If you do not want to initialize another client, select **No**, return to the initial Installation Options dialog, and skip to the next section *Editing AUTOEXEC.NCF* on page 95
 - If you want to initialize another client, select **Yes**. The maximum is four clients (Client 1 plus three additional clients).

The dialog shown in Figure 8-1 on page 90 appears again. However, this time the driver is obtained from your hard disk instead of the CD-ROM.

9. Select the same driver that you installed for the previous client. Ethernet and Token Ring cannot be mixed on the same machine.
10. Repeat the configuration procedures for the new client beginning with step 1 on 92.

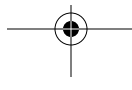

Editing AUTOEXEC.NCF

A few commands need to be added to the AUTOEXEC.NCF file in order to automate the ATM requirements at boot time. If not added to the file, the commands have to be entered manually each time the NetWare server is started.

To edit to the AUTOEXEC.NCF file, do the following:

1. With the NetWare **install** utility up and running, go to the initial Installation Options dialog if you are not there already.
2. Select **NCF files** option, then select **Edit the autoexec.ncf** to open the file for editing.

3. Find the last BIND command for the adapter.

For example, if Client 1 through Client 4 are initialized, the last Bind command should be similar to:

```
bind ipx 4815SI_4 net=<random_8_digits>
```

4. Insert the following commands in the line immediately following the last BIND command:

```
load asig  
load cvconf
```

5. If you are installing only one adapter and none of the clients are to be an IP over ATM client,
 - a. Save and exit the AUTOEXEC.NCF file.
 - b. Exit the NetWare **install** utility.
 - c. Reboot the server.
 - d. Go to *Configuring the Adapter to the Network* on page 101.

Continue the installation with the next section.

Changing a LEC to an IP over ATM Client

If the load line for an initialized client is not modified with a specific entry (IPENABLE=Y) the driver assumes the client is an LEC and proceeds with the LANE activity for joining a network. It does not make any difference which client is set for IP over ATM. The required items are that TCP/IP is installed on the machine and the client is configured to use the TCP/IP protocol. See *Configuring Protocols and Parameters* on page 91.

To set an IP over ATM client, do the following:

1. Find the set of LOAD and BIND commands in the AUTOEXEC.NCF file that represent the specific client you intend to be the IP over ATM client.

For example if you configured Channel 2 (Client #2) for TCP/IP communications, you would look for a set of commands similar to,

```
LOAD 4815SI CHANNEL=2 ELAN=engr3 \
  FRAME=Ethernet_II NAME=ch2_sl2 \
  SLOT=2
```

```
BIND IP to ch2_sl2 ARP=Yes \
  ADDRESS=123.234.100.015 \
  MASK=255.255.255.0
```

2. To make this client an IP over ATM client, add the term **IPENABLE=Y** to the end of the LOAD line.

For example,

```
LOAD 4815SI CHANNEL=2 ELAN=engr3 \
  FRAME=Ethernet_II NAME=ch2_sl2 \
  SLOT=2 IPENABLE=Y
```

Only one client can be set as an IP over ATM client.

3. If you are installing only one adapter,

- a. Save and exit the AUTOEXEC.NCF file.
- b. Exit the NetWare **install** utility.
- c. Reboot the server.
- d. Go to *Configuring the Adapter to the Network* on page 101.

Continue the installation with the next section.

Configuring Multiple Adapters

The NetWare **install** utility does not provide for multiple adapter configurations. The driver commands must be installed manually for each additional adapter in the server. This is accomplished by adding a set of **LOAD** and **BIND** commands in the AUTOEXEC.NCF file for each client on an additional adapter. The new commands must appear before the **load asig** command that was added to the file in the previous section. The easiest way to add these commands is to copy and paste a set of existing commands, then edit the parameters to support a different adapter.

The format of the **LOAD** command is as follows:

```
load <driver> \  
  CHANNEL=<channel_number> \  
  ELAN=<network_name> \  
  FRAME=<frame_type> \  
  NAME=<channel_name> \  
  SLOT=<slot_number>  
  IPENABLE=Y (for IP over ATM only)
```

Configuring Multiple Adapters

LOAD command option	Description
<i><driver></i>	The name of the driver should not change unless the speed of the adapters are different. Ethernet and Token Ring cannot be mixed on the same machine.
CHANNEL	The client number for the adapter. Range of <i><channel_number></i> is 1 – 4.
ELAN	The name of the emulated LAN for which this client is the NetWare server.
FRAME	The four options for Ethernet drivers are: FRAME = Ethernet_802.2 FRAME = Ethernet_802.3 FRAME = Ethernet_II FRAME = Ethernet_802.2_Snap For Token Ring drivers, use the parameter FRAME=Token-Ring
NAME	Each client must have a unique name for binding the protocol to the driver.
SLOT	The number of the slot in which the adapter is located.
IPENABLE	(For IP over ATM clients only.) Variable must be set to Y . Only one client on each adapter can be an IP over ATM client.

The format of the BIND command for IPX is as follows:

```
BIND IPX to <channel_name> \
NET=<elan_number>
```

IPX BIND command option	Description
<channel_name>	The NAME of the channel in the previous LOAD command for which you want to bind the IPX protocol.
NET	The unique identification number in hex format for the emulated LAN.

The format of the BIND command for TCP/IP is as follows:

```
BIND IP to <channel_name> \
ARP=<enable_arp> \
Address=<IP_address> \
Mask=<net_mask>
```

TCP/IP BIND command option	Description
<channel_name>	The NAME of the client in the previous LOAD command for which you want to bind the IP protocol.
ARP	Enables or disables the ARP protocol. The two settings for <enable_arp> are Yes to enable and No to disable.
Address	The Internet address for the channel. The format is dotted decimal notation in the form xxx.xxx.xxx.xxx, where xxx ranges from 0 to 254.
Mask	The most commonly used mask is ff.ff.ff.0, or 255.255.255.0 in decimal notation.

Configuring Multiple Adapters

At bootup, the system must load the TCP/IP protocol stack before encountering a **BIND IP** command. Check the AUTOEXEC.NCF file and make sure the following command precedes any driver **LOAD** commands:

```
LOAD TCPIP RIP=Yes FORWARD=No<
```

For example, if you are installing an additional adapter in slot #2 with IPX for one client and TCP/IP for a second client, entries to the AUTOEXEC.NCF file would be similar to the following:

```
LOAD TCPIP RIP=Yes FORWARD=No

LOAD 4815SI CHANNEL=1 ELAN=enr2 \
  FRAME=Ethernet_802.3 NAME=ch1_sl2 \
  SLOT=2

BIND IPX to ch1_sl2 NET=99A64B52

LOAD 4815SI CHANNEL=2 ELAN=enr3 \
  FRAME=Ethernet_II NAME=ch2_sl2 \
  SLOT=2

BIND IP to ch2_sl2 ARP=Yes \
  ADDRESS=111.222.333.015 \
  MASK=255.255.255.0
```

When editing is complete for all channels on all adapters:

1. Save and exit the AUTOEXEC.NCF file.
2. Exit the NetWare **install** utility.
3. Reboot the server.

Continue the installation with the procedures in the next section.

Configuring the Adapter to the Network

The Interphase CellView utility is used to enable and configure the clients to the network. See *CellView Utility for NetWare Servers* on page 103 for details on how to use the utility.

With the driver installed and the AUTOEXEC.NCF file amended as described in the previous sections, do the following:

1. If the adapter(s) are not installed, halt the machine and install the adapters at this time.
2. If not done in the previous step, reboot the machine.
3. Configure the adapter(s) to the network with the Interphase CellView utility by entering the command:

```
load cellview
```

The main CellView dialog appears with a listing for each EISA ATM adapter installed in the machine.

4. If more than one adapter is installed in the machine, move the highlight to the adapter to be configured.
5. Select **Setup**.
6. Enable and configure the clients that were initialized in the previous sections.
 - a. From the Setup dialog, select **LEC** and configure the LECs.
 - b. From the Setup dialog select **1577**, if needed, to configure the IP over ATM client and the ARP server (optional).
7. If the LECS and the LESs are to be on this machine, enable the LECS and the quantity of LESs as required.

Removing a Driver

8. When complete, exit the CellView utility.

The installation of the driver for the EISA ATM adapter is complete.

Removing a Driver

To remove a driver from the AUTOEXEC.NCF file, do the following:

1. At the system prompt, enter the command:

```
load install
```

2. When the Installation Options dialog appears, select **NCF files options**, then select **Edit the autoexec.ncf** to open the file for editing.

3. Remove the LOAD and BIND commands for each channel of the PCI ATM adapter by deleting all lines similar to the following:

```
LOAD 4815SI CHANNEL=1 ELAN=engr2 \
    FRAME=Ethernet_802.3 NAME=ch1_sl2 \
    SLOT=2
```

```
BIND IPX to ch1_sl2 NET=99A64B52
```

If the driver(s) are not being reinstalled, then remove the commands:

```
load asig
load cvconf
```

4. Save and exit the AUTOEXEC.NCF file.
5. Exit the NetWare **install** utility and reboot the server.

Do not attempt to reinstall the drivers before rebooting the NetWare server.

CellView Utility for NetWare Servers

9

Overview

This utility is used to configure the ATM clients and services on file servers running Novell NetWare Server version 3.12, 4.10, or 4.11. All screens and dialogs are in text format and require input from the keyboard to navigate the utility. You do not have to reboot the server for the edits to take effect. Pressing the F10 key at any time sends your changes to the driver for immediate, dynamic update.

The driver takes advantage of the more recent evolutions in switch designs where SVCs and PVCs can be mixed throughout the network. For example, you can have multiple clients using SVC signalling, and at the same time have a dedicated PVC between a client and another endstation on the network. Using CellView you can perform the following:

- Enable, disable, and configure up to four LECs and one IP over ATM client per adapter
- Set up PVC communications with other endstations
- Enable, disable, and configure up to eight LESs and one IP over ATM ARP server per adapter
- Enable, disable, and configure one LECS per adapter
- Display operating statistics for
 - SONET, signalling, and cell level activity
 - ATM Adaptation Layer 5 (AAL5) activity
 - LEC membership and activity
 - IP over ATM activity
 - LECS and LES activity

Getting Started

The degree of configuration needed for the adapter(s) depends largely upon the services already installed on the network. For example, if the LECS and LESs are up and running elsewhere in the network, you only need to enable and configure the local clients. If you enable the LECS add LESs on a local adapter, you should set all endstations in the network to contact the Interphase LECS at boot time.



NOTE

The dialogs in the Statistics group are included in the CellView utility to assist you and Interphase personnel in the event a problem occurs with the adapter or with your ATM network. Detail interpretation of the statistics is beyond the scope of this manual. However, limited procedures for using the dialogs are included in the troubleshooting sections of this Users Guide.

Getting Started

The procedures in this section assume that at least one ATM adapter is installed in the NetWare server, the software driver is installed, and the machine has been rebooted prior to running the CellView utility. If not, see the appropriate chapter in this users guide for installation instructions.

To start the CellView utility, enter the command,

```
load cellview
```

The main CellView menu appears as shown in Figure 9-1 on page 105.

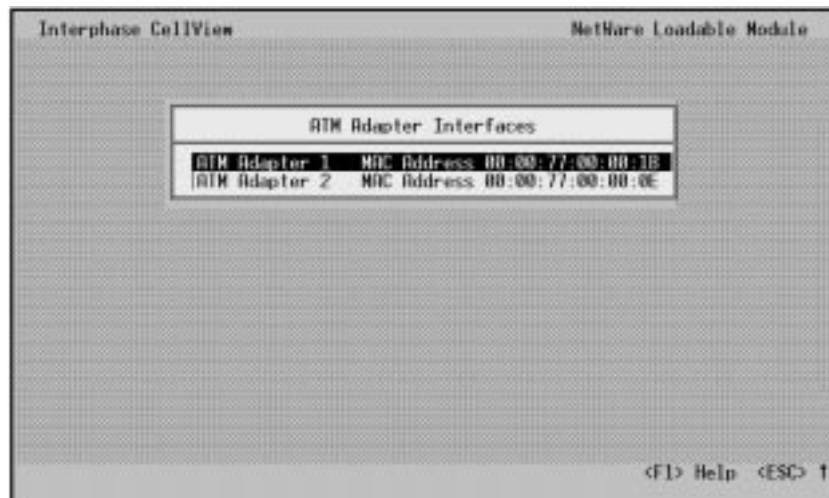
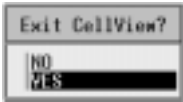

Figure 9-1. Main CellView Menu

The main CellView menu contains a list of the ATM adapters installed in the NetWare server, and has three keyboard options.

With this key . . .	You can do this . . .
F1	Activate the Help dialog.
ESC	Exit the CellView utility.  A dialog appears, as shown at left, for selecting YES to exit or NO to return to the CellView utility.
Enter	Select an adapter. The contents of each subsequent dialog are tied to the adapter being highlighted in the ATM Adapter Interfaces box.

Getting Started

The first dialog to appear when pressing the Enter key at the main CellView menu is similar to Figure 9-2, allowing you to choose either the Statistics or the Setup routines.

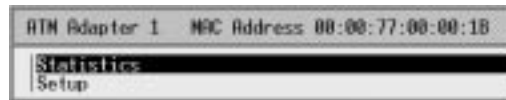

Figure 9-2. Selecting Statistics or Setup

Statistics Option

Contains dialogs to display:

- Signalling
- AAL5
- LECs
- LESs
- LECS
- IP over ATM client

Setup Option

Contains dialogs to configure:

- LECs (4 maximum)
- LEC PVC connections
- LESs (8 maximum)
- LECS
- IP over ATM client and ARP server
- IP over ATM PVC connections

Setup

Up to four LECs and one IP over ATM client can be enabled per adapter. You must have at least one client enabled and fully configured before running any applications on the network. Dialogs are also provided for enabling an LECS and up to eight LESs for the ATM network. No particular order is required for configuring the clients and services. If you are going to enable the LECS and the LESs, you should configure these first before configuring the clients. At minimum

Common keyboard commands for the dialogs are as follows:

With this key . . .	You can do this . . .
F1	Activate the Help dialog.
F2	Change the dialog to edit mode.
F10	Send your changes to the driver for immediate, dynamic update.
TAB	Move the cursor to the next edit field in the dialog if the edit mode (F2) is active; otherwise, move the cursor to the next dialog.
<numeric keys 1-4>	Select clients 1 through 4 when displaying the LEC dialogs.
<numeric keys 1-8>	Select servers 1 through 8 when displaying the LES dialogs.
ESC	Exit the dialog.

Confirming Edits

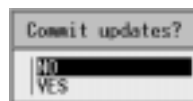

When exiting a Setup dialog that has been edited or changed, a prompt appears as shown at left. If you wish to save the

Setup

updates, select **YES** and the changes are sent to the driver for immediate action. You do not have to reboot the machine for the changes to take effect. Otherwise, select **NO** and another dialog appears, advising the updates are being discarded.

A directory for the dialogs under Setup is as follows:

Dialog	Page
LAN Emulation Clients	108
LEC PVC Table	111
IP over ATM Client and Server	115
IP over ATM PVC Table	117
ELAN Services	121
LAN Emulation Configuration Server	121
LAN Emulation Servers	123

LAN Emulation Clients

The driver allows up to four LECs to be enabled at a time. A client can be enabled only if it was initialized during installation of the driver. Each client has a dialog for their configuration. It contains all the parameters to establish communications with an LECS at bootup, or can be set to contact an LES directly. The clients can be enabled for SVC and PVC communications or set to communicate with PVC only. The procedures for setting up PVCs are contained in a separate dialog.

Path

From the initial CellView dialog,

1. If more than one adapter is installed in the machine, move the highlight to the adapter of choice.
2. Select **Setup**.

3. Press **F2** when the cursor is on the client's LEC to edit.
4. Press **F2** when the cursor is on the edit.

The LEC dialog appears as shown in Figure 9-3. In this example, LEC 1 is the client.

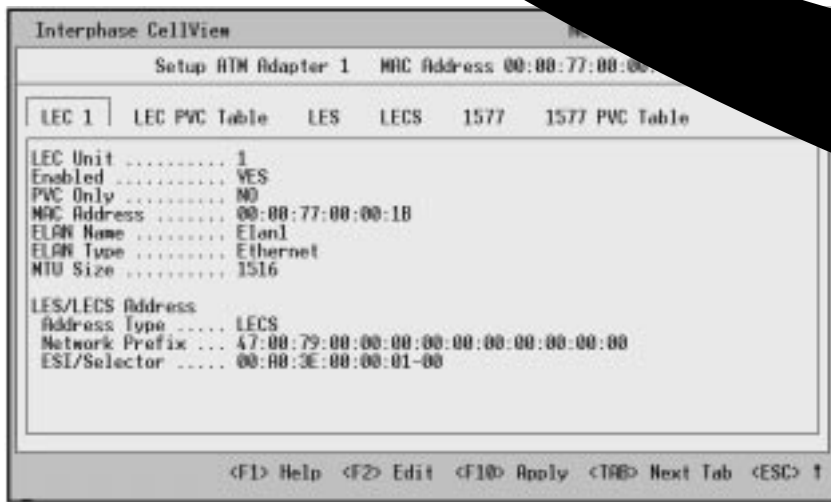
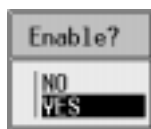

Figure 9-3. CellView LEC Setup

Enabled



When set to **NO**, the client is disabled. All settings in the dialog are ignored by the driver. If using PVCs only, the client must be enabled in order for the driver to recognize the client. .

PVC Only

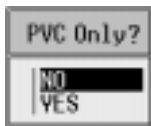

When set to **Yes**, all LANE activity for the client is disabled. You need only to set up the table as described in *LEC PVC Table* on page 111.

*Setup***MAC Address**

(Display Only) The text field contains the MAC address of the client. Client 1 is assigned the base address of the adapter. The remaining clients use an increment of the base for their MAC address.

**NOTE**

In Token Ring applications, the MAC Address is in non-canonical format.

ELAN Name

This is the network name of the emulated LAN that you prefer the client to join. Some configuration servers require a name while others do not. The Interphase LECS and LESs do not require a name unless Strict ELAN Name is enabled on the LES, or you need to differentiate between two or more LESs with the same MTU size and ELAN type. Refer to your server documentation for the exact requirements. The setup of the Interphase servers begins on 121.

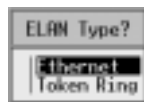
ELAN Type

All nodes on the same logical subnet must use the same frame type. If an edge device to a legacy LAN is part of the ELAN, the frame type for that edge device must be used.

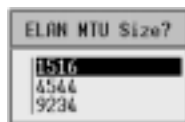
ELAN MTU Size

As with the ELAN Type, all nodes that are part of the same logical subnet must use the same MTU size. At installation of the driver,

the MTU size has a default value of 1516. Do not select another value for the ELAN MTU Size unless the MTU value in the client's LOAD line in the AUTOEXEC.NCF file has been changed accordingly. The setting in CellView and the setting in the AUTOEXEC.NCF file must be the same value. See the **readme** file in the **Netware** directory on the installation CD-ROM for more information.

LECS/LES ATM Address

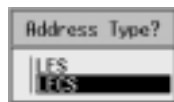

There are two options for setting the mode of contact at bootup.

- **LES:** Uses the 20-byte ATM address in the Network Prefix and ESI/Selector fields, to contact an LES directly.
- **LECS:** Loads the ATM Forum's well-known address in the Network Prefix and ESI/Selector fields. The LEC uses this address to contact the LECS at bootup.

LEC PVC Table

A PVC configuration table is provided to set permanent links between a client and other endstations on the network. A 6-byte MAC address and a VCI number are associated with each PVC. Packets from the upper layers whose destination MAC address matches an address in the PVC table are transmitted on that PVC.

The corresponding LEC must be enabled in order to use PVC communications. If the PVC Only parameter in the client's dialog is set to **YES**, make sure the client's MTU Size is set to the appropriate value for the PVC communications.

Setup

Changes to the table take effect immediately and do not require a reboot of the computer. All PVCs have to be set up and torn down manually. The MAC address of the target station must be mapped to a VCI in the local host. A similar setup is required at the target station using the MAC address of the local client. The two endstations must be linked together manually through the ATM switch(s).

Path

From the initial CellView dialog ,

1. If more than one adapter is installed in the machine, move the highlight to the adapter of choice.
2. Select **Setup**.
3. Check the LEC dialog and make sure that it is enabled. See *Enabled* on page 109 for details.
4. Exit the LEC dialog and tab to **LEC PVC Table**.
5. If you wish to edit a table other than for LEC 1, press **2-4** to select tables for LEC 2 through LEC 4.
6. Press **F2** when ready to edit.

The PVC table appears, as shown in Figure 9-4. In this example, the table for LEC 1 is selected.

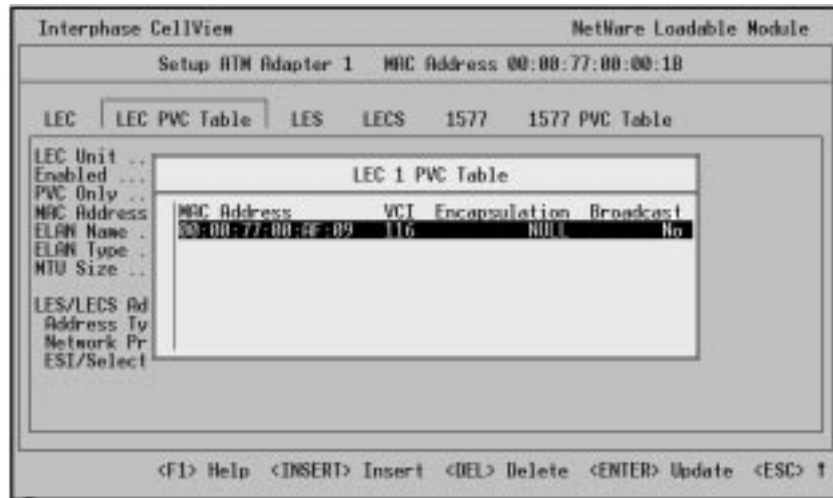

Figure 9-4. CellView LEC PVC Table

Keyboard commands for the tables are:

- **Insert:** Adds a new entry to the table.
- **Delete:** Removes the highlighted entry from the table.
- **Enter:** Allows updates to an existing entry.

When using **Insert** or **Enter**, the dialog in Figure 9-5 appears.

Setup

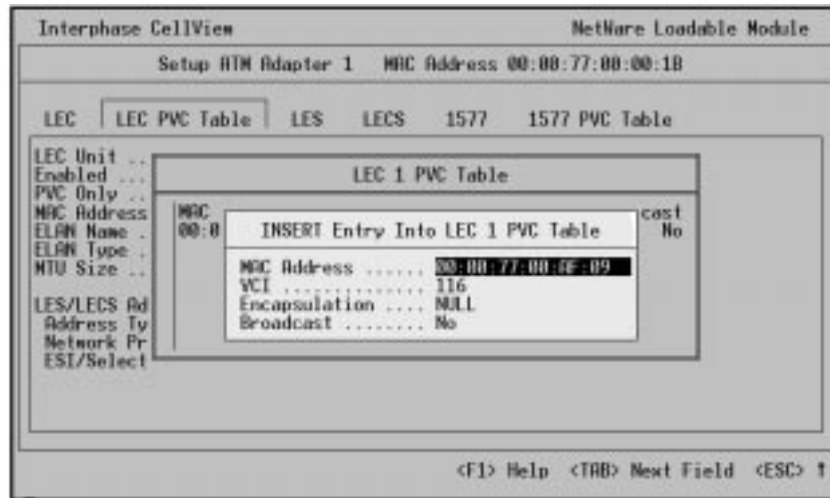

Figure 9-5. CellView LEC PVC Setup

MAC Address

The 6-byte address of the target station. The address should be entered in the natural format for the ELAN. If Token Ring for example, the address is entered in non-canonical form.

VCI

The circuit number which the LEC uses to communicate with the target. In most cases, the range is 32–1023. The VPI is set to a value of zero in the driver and cannot be edited.

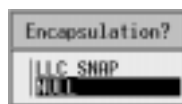
Encapsulation

Offers a selection for either LLC_SNAP or NULL. Both the host and the target must use the same encapsulation method.

Broadcast

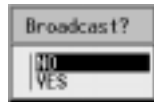

When set to YES, enables the entry as a Broadcast PVC. All broadcast/multicast packets from the upper layers are transmitted on this PVC. A maximum of 16 PVCs can be enabled as a Broadcast PVC.

IP over ATM Client and Server

This client conforms to the RFC-1577 specification using IP over ATM where no multicast or broadcast services are available. You can set the adapter as the ARP server for the IP over ATM network and, if needed, set the client for PVC communications only. The procedures for setting up the PVC table are contained in a separate dialog.

Path

From the initial CellView dialog ,

1. If more than one adapter is installed in the machine, move the highlight to the adapter of choice.
2. Select **Setup**.
3. Tab to **1577**.
4. Press **F2** to edit.

The IP over ATM dialog appears, as shown in Figure 9-6 on page 116.

Setup

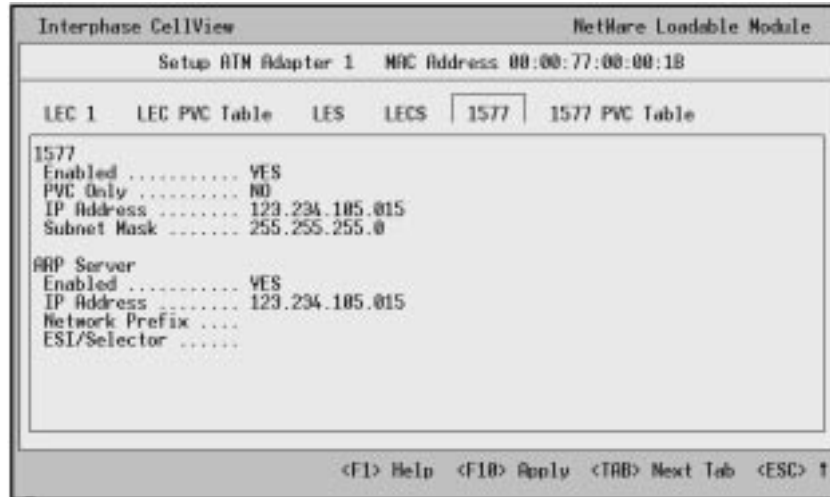
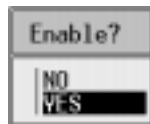
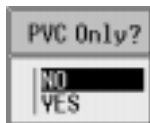

Figure 9-6. CellView IP over ATM Setup

Client – Enabled

When set to **NO**, the IP over ATM client is disabled. All settings in the dialog are ignored by the driver. If using PVCs only, the client must be enabled in order for the driver to recognize the client.

Client – PVC Only

Whenset to **Yes**, all SVC activity for the client is disabled. All you need to do is configure the PVCs as described in *IP over ATM PVC Table* on page 117.

Client – IP Address and Subnet Mask

When enabled, the IP address and subnet mask for the client (configured during the installation of the driver) are loaded automatically in the IP Address and Subnet Mask fields, respectively.

ARP Server – Enable

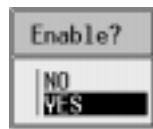

Enables the host adapter as the ARP server for your IP over ATM network. When set to **YES**, the IP address for the client is automatically loaded in the ARP Server – IP Address field. You should set all other endstations to contact the ARP server at this address during bootup.

ARP Server – IP Address

If the host adapter is not the ARP server, you must enter the IP address of the ARP server located elsewhere in the network.

ARP Server – Network Prefix and ESI/Selector

If the host adapter is not the ARP server, the IP over ATM driver must know the ATM address of the ARP server. When the system is powered up, a call is placed to the ARP server with the ATM address in these two fields.

IP over ATM PVC Table

A PVC configuration table is provided to set permanent links between the client and other endstations on the IP over ATM network. An IP address and VCI number are associated with each PVC. Packets from the upper layers whose destination address matches an address in the PVC table are transmitted on that PVC. The corresponding IP over ATM client must be enabled in order to use PVC communications.

Setup

Changes to the table take effect immediately and do not require a reboot of the computer. All PVCs have to be set up and torn down manually. The IP address of the target station must be mapped to a VCI in the local host. A similar setup is required at the target station using the IP address of the local client. The two endstations must be linked together manually through the ATM switch(s).

Path

From the initial CellView dialog ,

1. If more than one adapter is installed in the machine, move the highlight to the adapter of choice.
2. Select **Setup**.
3. Check the 1577 dialog and make sure that it is enabled. See *Client – Enabled* on page 116 for details.
4. Exit the IP over ATM dialog and tab to **1577 PVC Table**.
5. Press **F2** to edit.

The PVC table appears, as shown in Figure 9-7 on page 119.

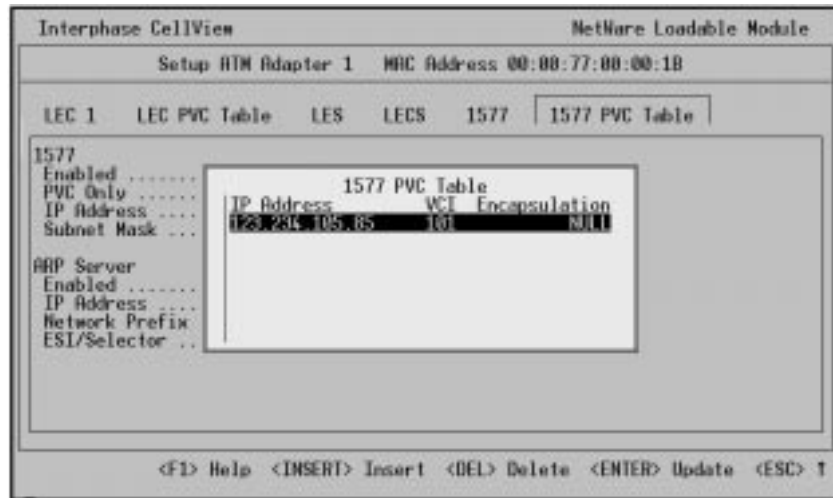

Figure 9-7. CellView IP over ATM PVC Table

Keyboard commands for the tables are:

- **Insert:** Adds a new entry to the table.
- **Delete:** Removes the highlighted entry from the table.
- **Enter:** Allows updates to an existing entry.

When using **Insert** or **Enter**, the dialog in Figure 9-5 appears.

Setup



Figure 9-8. CellView PVC Setup

IP Address

The decimal address of the target station.

VCI

The circuit number which the client uses to communicate with the target. In most cases, the range is 32–1023. The VPI is set to a value of zero in the driver and cannot be edited.

Encapsulation

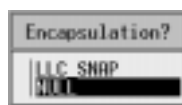

Offers a selection for either LLC_SNAP or NULL. Both the host and the target must use the same encapsulation method.

ELAN Services

In order to communicate on an ATM network, an LEC must join an emulated LAN which consist of a group of endstations that communicate among themselves with the same MTU size, the same frame format, and the same broadcast/multicast services. The central server for this ELAN is the LES. The management of which LEC joins which LES is handled by the LECS. This section contains the instructions for setting up the LECS and up to eight LESs.

LAN Emulation Configuration Server

The LECS provides a central point of contact on the network for each LEC at boot time. The client sends the LECS a request for the type of ELAN it wants to join. The LECS responds with the current ATM address and the configuration parameters of the appropriate LES.

Path

From the initial CellView dialog,

1. If more than one adapter is installed in the server, select an adapter.
2. Select **Setup**.
3. Tab to **LECS**.

The configuration dialog for the LECS appears, as shown in Figure 9-9 on page 122.

4. Press F2 to when ready to edit.

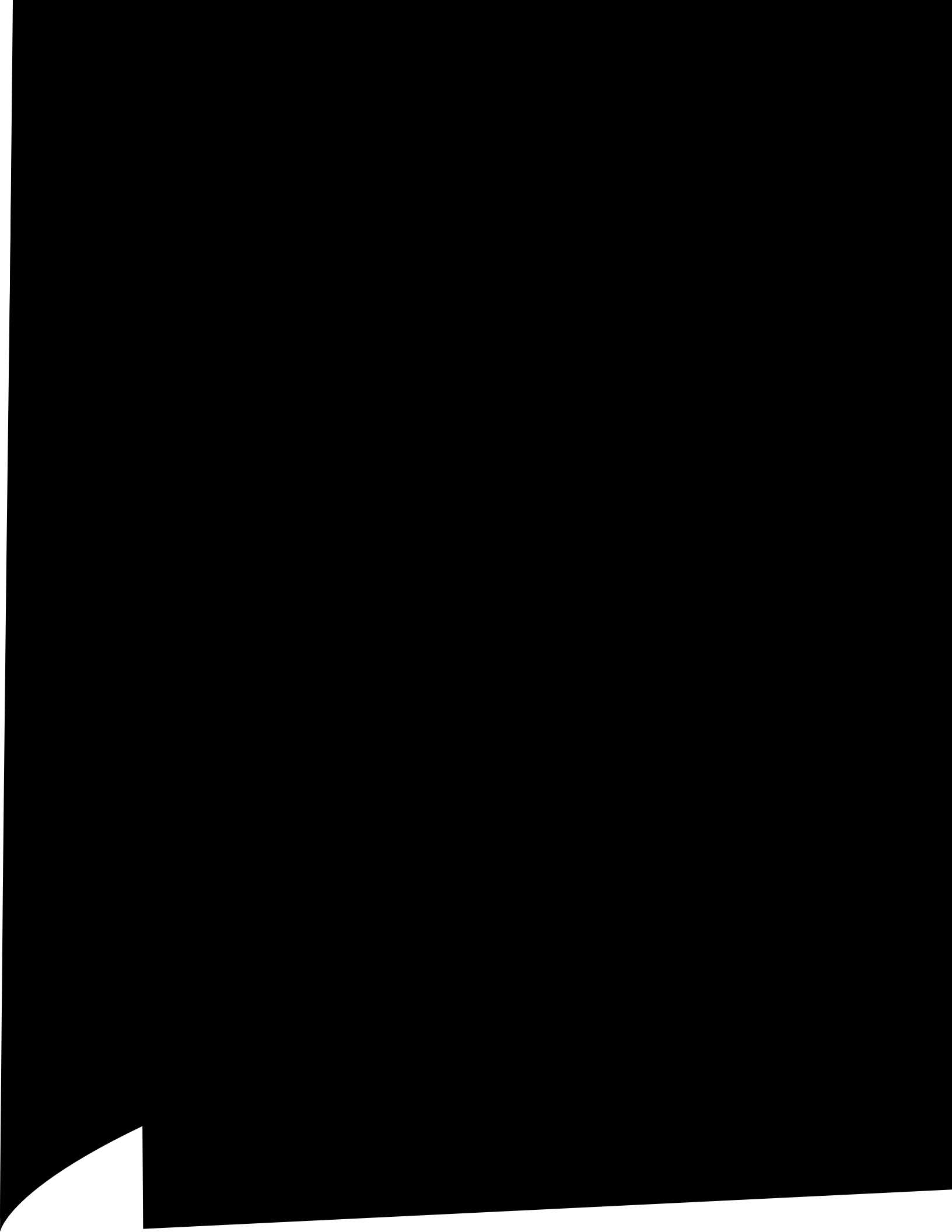

Register LECS

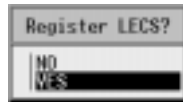

Select **YES** to register the ATM address in the Network Prefix and ESI/Selector fields with the switch at bootup. If your switch does not support address registration, select **NO**.

You will have to manually enter the ATM address of the LECS in the switch.

ELAN Type

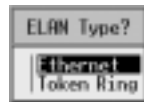

Some vendors may not require the ELAN type to be included in the initial requests to the LECS. If not included, the LECS attempts to assign the client to an LES which matches the Default

ELAN Type and using an MTU size equal to or less than the MTU size requested. When the MTU size is omitted in the client's request, the corresponding value in the Default Ethernet MTU Size or Default Token Ring MTU Size is used.

LAN Emulation Servers

The LES is a central server in the ELAN which provides address registration, address resolution, and broadcast services for all its members. When an LEC joins an LES, the MAC-ATM relationship of the client is registered with the server. The LES maintains a running account of these addresses to resolve queries from the ELAN members.

The connection between the LES and each LEC is a permanent, open connection as long as the client is up and running. The LES maintains a table containing information about each client and uses this table to provide address resolution services to the ELAN. When an endstation is disconnected or turned off, the LES removes the client(s) from the table automatically. Relocating an endstation is a matter of physically moving the hardware to a new location and

Setup

connecting it to the same or another ATM switch. At bootup, the client(s) rejoin the same LES again with a new ATM address.

Path

From the initial CellView dialog ,

1. If more than one adapter is installed in the server, select an adapter.
2. Select **Setup**.
3. Tab to **LES**.
4. If you wish to edit an LES other than LES 1, press **2-8** to select the dialogs for LES 2 through LES 8.
5. Press **F2** when ready to edit.

The configuration dialog for the LES appears, as shown in Figure 9-10.

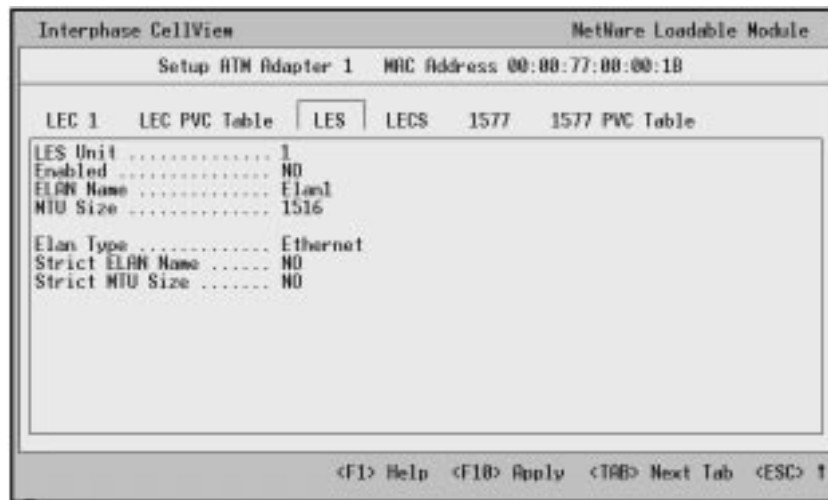
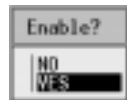

Figure 9-10. CellView LES Setup

Enable



When set to **NO**, all settings in the dialog are ignored by the driver.

ELAN Name

This is the network name of the emulated LAN for which the LES is providing services. It is not required in order for a LEC to join the group. If Strict ELAN Name (see 126) is set to YES, the name in the LEC request has to match (case sensitive) the name in the text field.

MTU Size



This is the MTU size for the ELAN. The value in the selection box depends upon the setting of the ELAN Type (next parameter).

The selection is **1516** when the ELAN type is set to Ethernet and **4544** when set to Token Ring. If Strict MTU Size (see 126) is set to YES, the request from the LEC must match the MTU Size; otherwise, the server will not allow the LEC to join the group.

ELAN Type

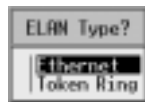

Specifies the type of framing used for all communications between endstations. If an edge device to a legacy LAN is part of the ELAN, the frame type must be set to interface with that edge device.

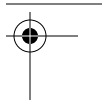
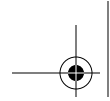

ELAN Name

Specifies whether the request coming from the REC has to match (case sensitive) the entry in the ELAN Name field.

Specifies whether the request coming from the REC has to match exactly the entry in the size field.

group are for
are included in the
phase personnel in the
or with your ATM
principles and
beyond the scope of
or using the dialogs
of this Users
statistics for local
statistics from

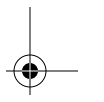

Troubleshooting

10

This chapter provides possible solutions for common problems encountered while installing and operating the ATM adapter. Before proceeding with the troubleshooting, make sure that you have carefully followed the steps for installing the hardware and the software, and that you have rebooted the system. Also, check the systems log for your operating system to see what kind of errors, if any, are being recorded. This may provide some insight to the problem.

If the information in this chapter does not resolve the problem, contact Interphase Customer Support at one of locations listed in the front of this users guide.

Verifying Driver Installation

An application program does not have to be running in order to verify that the driver is up and running. At bootup of the endstation, certain systems communications must take place between the client and the server (through the switch) in order for the client to log on to the network. Use the Statistics routines in the Interphase CellView utility to monitor this traffic as well as for checking a few other essential items. If you find an item in error, or you suspect something is wrong with your setup, see *Network Problems* on page 133.

To perform a quick check of the operating statistics for an adapter, do the following:

1. Start the CellView utility.

If needed, see *Getting Started* on page 59 for startup instructions.

Verifying Driver Installation

2. When the main CellView dialog appears, select an adapter in the listbox; that is, if more than one adapter is installed in the machine.

3. Select **Stats**.

The Signalling dialog appears for the selected adapter.

- All three graphical LEDs in the Signalling State box should be green in color.
- The three text fields in the State Detail box should read similar to:

ILMI: ILMI Registered

QSAAL: Data transfer ready

Signalling: Signalling ready

- There should be some traffic in the Signalling Statistics box for both Frames In and Frames Out.

4. Select the **AAL5** tab.

- All six graphical LEDs in the SONET box should be green in color.
- There should be some traffic in the AAL5 Statistics box.

5. If at least one LEC on the adapter is enabled, select the **LEC** tab.

a. Select the tab for an enabled LEC.

- The LEC graphical LED should be green in color.
- There should be some traffic in the Tx Packets and Rx Packets fields of the display boxes.

b. Repeat the above step for all enabled LECs.

6. If the IP over ATM client is enabled, select the **1577** tab.

- The **1577** graphical LED should be green in color.

- There should be some traffic in the **1577** Statistics fields.

7. If more than one adapter is installed in the machine, repeat step **2** through step **6** for each additional adapter.

When complete, exit the CellView utility.

LED State and Function

The adapter has two LEDs, a green Link LED and a yellow Status LED with functions as shown in the following table.

LED	State	Function
-----	-------	----------

The Link LED indicates the condition of the physical link between the adapter and the ATM switch. When the green LED is lit, light or electrical current is flowing between the two sets of hardware; however, there may or may not be any data flowing through the cable.

The Status LED serves two functions. When the machine is turned on, the LED glows a solid yellow indicating the adapter has power, then begins blinking when the software driver is loaded.

LED State and Function

Problem	Possible Solution
Link LED not lit	<p>There is failure in the hardware which is preventing the adapter from completing a physical link with the switch.</p> <ol style="list-style-type: none">1. Check the switch. It must be up and running in order for the adapter to make a link.2. Unplug and reinstall the connectors.3. If this does not work, try a known, good cable.4. Check the transmit and receive wiring to see if they are reversed. For fiber see Figure 2-2 on page 12. For UTP connections, see <i>UTP Cabling</i> on page 141.5. If a known, good cable is installed, then try another adapter in the expansion slot. If the green LED does not illuminate, the problem is most likely at the switch. Confirm this by configuring the cable to another port on the switch.
Status LED not lit	<p>Power is not getting to the adapter.</p> <ol style="list-style-type: none">1. Do a power reset of the computer by turning the power off and then on again.2. Make sure the adapter is seated correctly in the expansion slot. Check for a bent pin or crack in the connector.3. Try another expansion slot.4. Try another adapter which is known to operate correctly.
Status LED lit, but not blinking	<p>The driver is not installed, or the driver is not installed correctly.</p> <ol style="list-style-type: none">1. Check the event log for your operating system to see if any errors were recorded during bootup that pertain to the ATM driver. This may provide some insight to the problem.2. Install or reinstall the driver.

Bootup Problems

These type of problems are usually hardware related. The board is located in the wrong slot, the bus address is incorrect or in conflict with another device, and so forth. If the machine worked properly before the adapter was installed, then the problem is most likely with the adapter or with the hardware that was removed and replaced during installation of the adapter.

Problem	Possible Solution
Computer does not boot up	<ol style="list-style-type: none">1. Check to see if the adapter is properly seated in the expansion slot. Reseat the adapter and restart the machine.2. Try a different expansion slot.3. Remove the adapter and reboot the system.4. If the system returns to a normal state, try a different interrupt setting or reinstall the configuration utility (if applicable). Change one setting at a time and record the settings in order to keep track of your changes. It is helpful to temporarily remove non-essential hardware in your computer to reduce the number of conflicts.5. Install an adapter that is known to work correctly. If the system boots up, the adapter in question is probably defective.

Bootup Problems

Problem	Possible Solution
Host adapter not found	<p>The operating system cannot find or does not recognize the adapter.</p> <ol style="list-style-type: none"><li data-bbox="643 569 1195 726">1. If this is your first bootup since installing the adapter, the configuration registers may not match what the operating system expects. Instead of rebooting the system, turn the power off and then on again to reset all components to an initial state.<li data-bbox="643 732 1195 858">2. The adapter is installed in the wrong slot. Make sure the adapter is in the slot for which the driver is configured. See your hardware manuals for the location of the proper expansion slots.<li data-bbox="643 865 1195 928">3. Make sure the adapter is seated correctly in the slot.<li data-bbox="643 934 1195 963">4. Try another expansion slot, if available.<li data-bbox="643 970 1195 1033">5. Try another adapter which is known to operate correctly.<li data-bbox="643 1039 1195 1165">6. Check the event log for your operating system to see if any errors were recorded during bootup that pertain to the ATM adapter or driver. This may provide some insight to the problem.

Network Problems

The procedures in this section assume the host workstation is up and running, the driver is loaded (yellow LED is blinking), and the adapter has formed a physical link (green LED is lit) with the switch. If needed, see *LED State and Function* on page 129 and the previous section, *Bootup Problems*.

Most of the problems discussed in this section concern getting the clients up and running, and logged on to the network. In all cases, check the event log for your operating system to see if the clients are being rejected by the LECS or the LES. It does not make any difference if the servers are located in the same endstation as the clients. Therefore, in order for the client to have any form of communication with a server:

- The switch must be configured correctly
- Signalling must be up and running
- The adapter must be assigned a network prefix
- At least one client must be enabled
- At least one LES must be present on the network

The debug options in the CellView utility (see *Debugging* on page 84) are an excellent tool for troubleshooting the adapter and network related problems. Messages are logged from various modules to assist in isolating the problem. Be sure to disable the options when debugging is complete.

Network Problems

Problem	Possible Solution
<p>Driver loads at bootup, but network clients are not connecting.</p>	<ol style="list-style-type: none"> 1. Use the Interphase CellView utility to check the state of signalling. <ol style="list-style-type: none"> a. Select Stats from the main dialog. b. If the graphical LEDs for Signalling in the Statistics dialog are green then signalling is up and running. See the next Problem item. c. If the graphical LEDs are red, exit to the main dialog and select Setup. e. Make sure the setting in the UNI Revision field is set to coincide with the UNI setting in your switch. 2. Use the Interphase CellView utility to check the hardware. <ol style="list-style-type: none"> a. Select Stats from the main dialog. b. Select the AAL5 tab. c. If one or more of the graphical LEDs in the SONET box is red in color, there is a failure somewhere in the cable or connectors. 3. Use the Interphase CellView utility to track communications between the adapter and the ATM switch. <ol style="list-style-type: none"> a. Select Global from the main dialog. b. Select Debugging. c. Enable Signalling. d. Enable ILMI. e. Exit CellView and reboot the machine. <p>All communications are now being tracked between the adapter and the signalling daemon in the switch, as well as the protocols used to monitor all the other traffic. Check the messages in the event viewer or the systems log of your operating system.</p> <p>Be sure to disable the options in CellView when debugging is complete.</p>

Problem	Possible Solution
Signalling is running, but network clients are not connecting	<p>Check the Network Prefix for the adapter.</p> <ol style="list-style-type: none">1. From the main dialog select Stats. There must be a 13-byte address in the Network Prefix field. If not, the switch is configured incorrectly or the signalling setup for the adapter is in error.2. Exit to the main dialog and select Setup.3. Make sure the settings for the Enable Address Registration, the ILMI Port Change Detection and the Register Nonstandard Prefixes coincide with the capabilities of your LAN Emulation services. <p>If automatic address assignment is not supported by the switch, the 13-byte address must be entered manually in the Network Prefix field.</p>
Signalling and Address Registration are working, but network clients are not connecting	<p>Check the settings for the client.</p> <ol style="list-style-type: none">1. From the main dialog select Setup/LEC/LEC#.2. Make sure the LECS/LES parameters are specified correctly. These concern settings and parameters that must coincide with the capabilities of your switch.3. The MTU size must be equal to or greater than the setting for an LES. For example if only one LES is enabled with an MTU of 9K and the client attempts to join with an MTU of 1516, the client will be rejected.4. Check the other settings in the dialog and make sure they coincide with at least one of the enabled LESs.

Network Problems

Problem	Possible Solution
A network application no longer works	<ol style="list-style-type: none">1. If the application program worked prior to the installation of the adapter, there is probably a hardware conflict. Some programs which access the hardware can cause a conflict at some point. This typically happens with hardware such as printers and modems.2. Use the Interphase CellView utility to track the API (Application Program Interface).<ol style="list-style-type: none">a. Select Global from the main dialog.b. Select Debugging.c. Enable API.The lower level functions of the API are now being tracked. These are the routines used by the application software to manage or obtain system resources. Check the messages in the event viewer or the systems log of your operating system. If no messages are being recorded, reboot the machine, run the application again, then check the message log. Be sure to disable the option in CellView when debugging is complete.

Specifications

A

Adapter

Review Note (Mel J.):

Need weight and power requirements for 4825 and 4875 adapters.

Item	Specification
Memory	4815: 128K or 512K buffer 4825: 128K buffer 4875: 128K, 512K, or 1M buffer 1K serial EEPROM Optional Expansion ROM 128K Control SRAM
Host Bus Interface	Fully compliant with EISA specifications (Version 3.12), BCPR Services, Inc. 1992
Network Interface	4815/4875: 155 Mbps SONET OC-3c fiber 4815/4875: 155 Mbps SDH STM-1 fiber 4815/4875: 155 Mbps SONET UTP 4825: 25.6 Mbps AF-PHY-0040.00 UTP
Standards Compliance	
Open Boot Interface	IEEE 1275
ATM Layer	CCITT I.361, ANSI T1S1/92-002R3
ATM Adaptation Layer	AAL5
Diagnostics	LEDs: - Green "Live incoming link" - Yellow "Status"

Operating Environment

Board Dimensions	Length: 339 mm, Width: 107 mm)
Weight	4815: 235 grams 4825: 4875:
Supply Voltage	5V (+/- 5%)
Power Requirements	(total for single slot) 4815: 2.0A at 5V 4825: 4875:

Operating Environment

Temperature	0–55° C / 32–131° F
Relative humidity	10–95% noncondensing
Altitude	0–15,000 feet

Storage Environment

This section assumes the adapter is stored in its original anti-static bag and box.

Temperature	-40–85° C / -42–185° F
Relative humidity	10–95% noncondensing
Altitude	0–50,000 feet

Network Connections

4815:		
	SC Duplex (155 Mbps)	Single Mode Fiber (8.25/125) Maximum cable length: 15 km Minimum cable length: 3 m
	SC Duplex (155 Mbps)	Multimode Fiber (62.5/125) Maximum cable length: 2 km Minimum cable length: 3 m
	RJ-45(155 Mbps)	Category 5 UTP Copper Maximum cable length: 100 m
4825:		
	RJ-45 (25.6 Mbps)	Category 3, 4 or 5 UTP Copper Maximum cable length: 100 m
4875:		
	SC Duplex (155 Mbps)	Multimode Fiber (62.5/125) Maximum cable length: 2 km Minimum cable length: 3 m
	RJ-45 (155 Mbps)	Category 5 UTP Copper Maximum cable length: 100 m

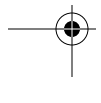
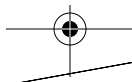
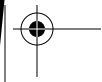
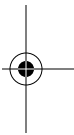
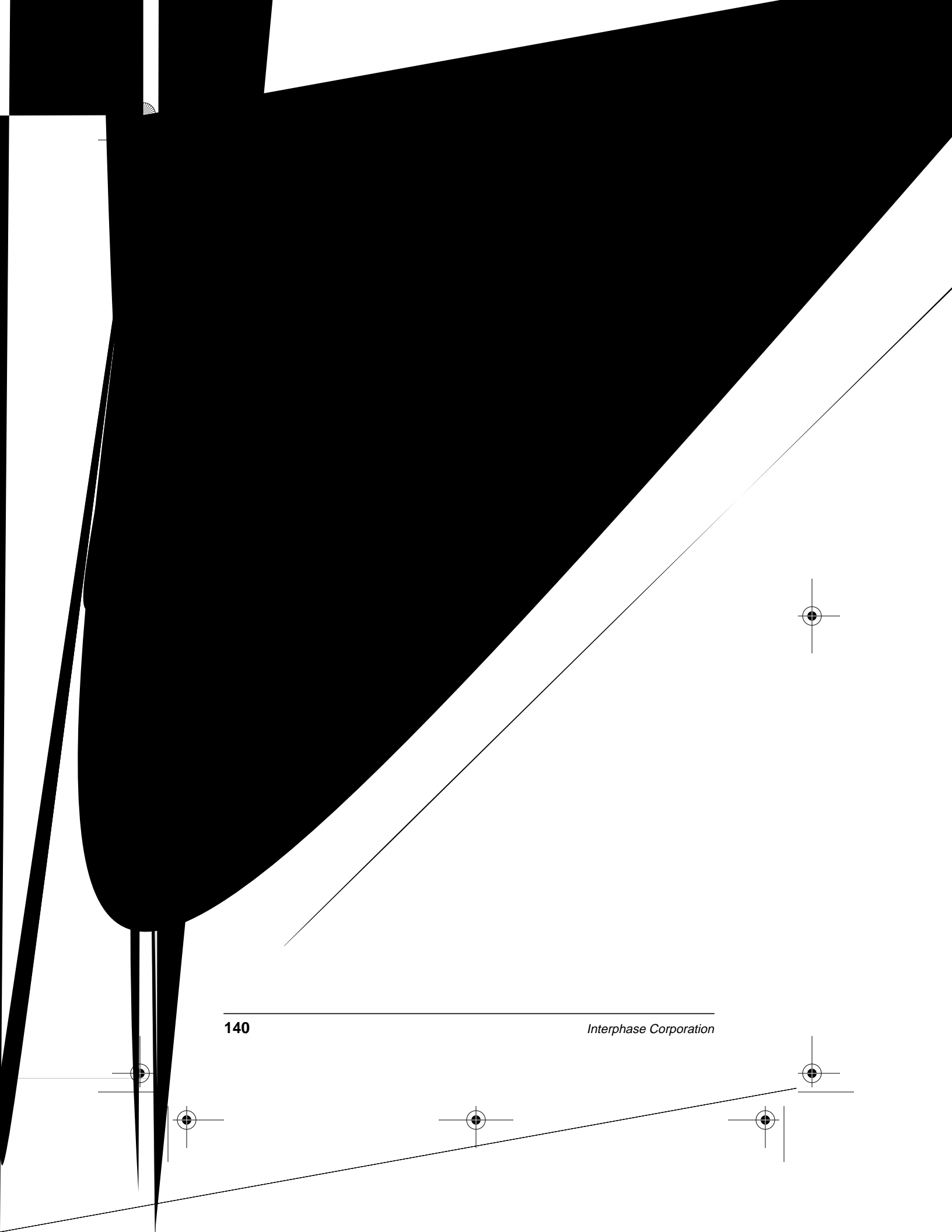

UTP Cabling



Straight-through Cable

To connect a EISA ATM adapter to an ATM switch, use a straight-through cable.

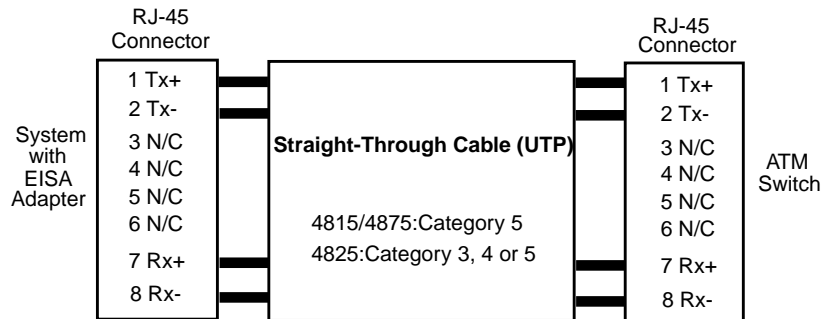

Crossover Cable

To connect two endstations back-to-back, use a crossover cable.

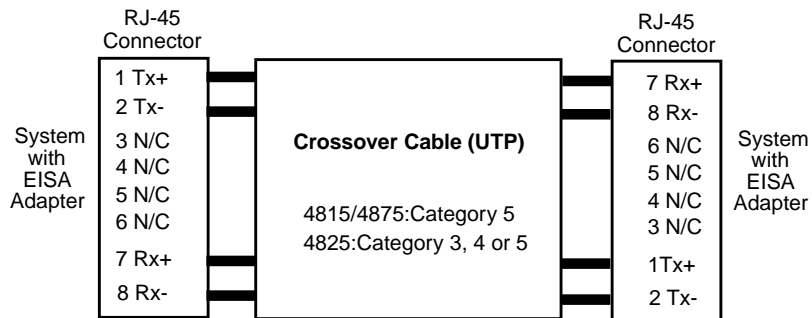

RJ-45 Connector Pinouts



CAUTION

For straight-through and crossover cabling to meet EMI specifications, the unused pairs must be connected at both ends of the cable to the Compu-shield and RJ-45 connectors.

RJ-45 Connector Pinouts

Pin assignments for the RJ-45 connector are as follows:

12345678

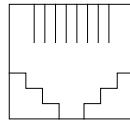

Pin #	Signal
1	Transmit (Tx+)
2	Transmit (Tx-)
7	Receive (Rx+)
8	Receive (Rx-)

ATM Technology Overview

C

Introduction to ATM

Asynchronous Transfer Mode (ATM) is a switched, connection-oriented technology that allows for sending voice, data, images, and video over the same network media. With significantly higher bandwidths, applications such as multimedia and teleconferencing are supported with a quality of service that is not available from legacy LANs such as Ethernet and Token Ring. However, ATM can be scaled down to interface with a wide range of existing network configurations. This flexibility in implementation is possible because of ATM's inherent scalability that extends from the desktop to supercomputers.

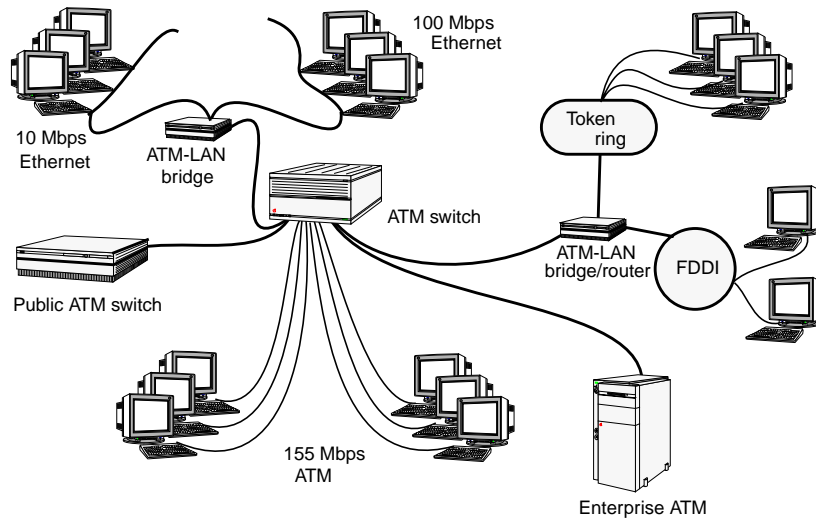

Figure C-1. ATM Network Topology

Virtual Circuits

The core concept of ATM is cell switching. Cell switching combines the benefits of the packet switching used in traditional data networks with the circuit switching technology of voice communications. All data, voice, and video are converted into small, fixed-length packets of 53 bytes each called cells. These cells provide a standard way to combine the differences in transmission rates required by data and images (bursty, variable-length packets) with the constant, average rate required by voice and full-motion video. Because all cells are the same length, the traditional overhead delays encountered with variable-length packets are virtually eliminated.

Virtual Circuits

ATM uses *virtual circuits* to create individual communication links between network nodes for transporting the 53-byte fixed-length cells. These virtual circuits carry all transmissions between nodes and maintain the correct cell sequence throughout the length of the transmission, as well as providing a defined Quality of Service (QoS).

Virtual Circuit Connections

A Virtual Circuit Connection (VCC) is a path or a connection between any source and any destination in the ATM network. There are two types of virtual circuits in an ATM network, permanent virtual circuits (PVCs) and switched virtual circuits (SVCs). A connection between two stations is handled by means of manual configuration (PVCs) or signalling (SVCs). All communication between the two end systems proceeds along the same VCC. The VCI in the ATM cell header is assigned per network link; that is, endstation-to-switch, switch-to-switch, switch-to-endstation, and so on.

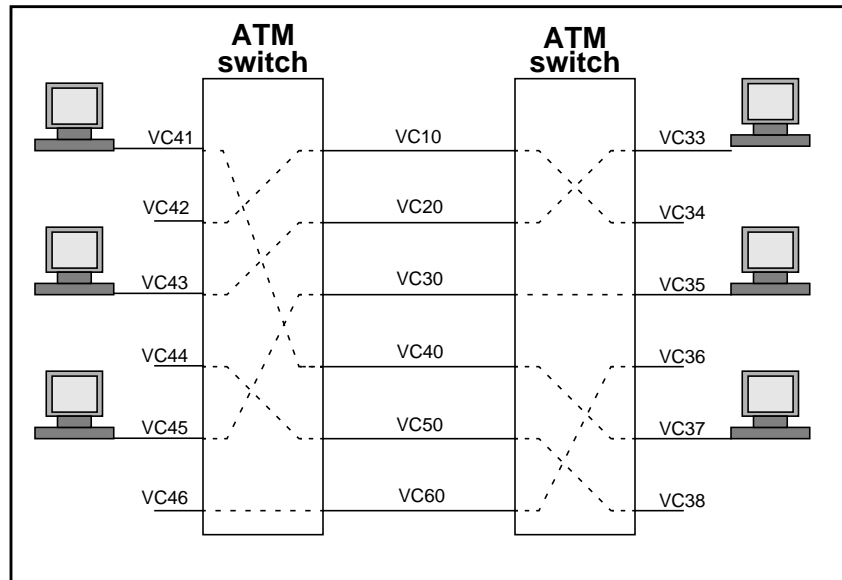

Figure C-2. Virtual Circuits

The Virtual Path (VP) creates groups of the VCs carried between the ATM entities, such as the ATM switches shown in Figure C-2. The VCs associated with a VP are globally switched without unbundling or processing the individual virtual circuits. Thus, the cell-carrying capacity of each VC is preserved, and the quality of service of the VP can be scaled to very high speeds.

Permanent Virtual Circuits

Permanent virtual circuits are permanent, static connections between the network nodes; that is, the nodes operate as if they are connected with a dedicated physical line. To implement PVCs, you create a table for each station listing the VCIs that identify the first steps in the paths leading to each of the other stations with which it is to communicate, as well as a master

Virtual Circuits

table that links all the information in the individual station tables at the switch. This means that when you move a station, you must recreate its table, as well as its information in the master table at the switch, in order for the station to reconnect to the network.

Switched Virtual Circuits

Switched virtual circuits (SVCs) are created dynamically for each session by signalling software in the endstations and the switches, and thus eliminate the manual work involved in implementing PVCs. SVCs are similar to a voice telephone network, where connections between any two end points on the network are created dynamically for each session and torn down when the exchange of information is complete. All the ATM switch has to do is identify the output port to which a received cell needs to be routed, and what the new VPI/VCI is on the output link.

Fixed-Length Cells

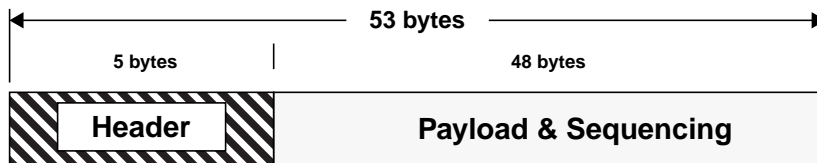

Breakdown of 5-byte Header

	Bits 0-3	Bits 4-7	
Byte #1	GFC/VPI*	VPI	
Byte #2	VPI	VCI	
Byte #3	VCI		
Byte #4	VCI	Payload Type	CLP
Byte #5	Header Error Control		

GFC: Generic Flow Control

VPI: Virtual Path Identifier

VCI: Virtual Circuit Identifier

CLP: Cell Loss Priority bit

* First 4 bits are used as GFC field in the case of User-Network Interfaces.

Figure C-3. The ATM Cell

Fixed-length cells of 53 bytes each are transmitted over the virtual circuit established between the sending node and the receiving node. Each cell contains a 5-byte header (for connection identification, flow control, routing, and error control) and 48 bytes of data. The fixed byte count allows fast hardware switching, lowers processing requirements, and practically eliminates the overhead associated with the processing of variable-length packets. As a result, ATM cells

Scalability

can be transmitted through multiple, contiguous connections and still maintain the time-sensitive quality of service required for audio and video applications.

Scalability

A major benefit of ATM is its inherent ability to support many different access and transmission speeds on different physical media. This is referred to as scalability. For example, a cell generated on a 155 Mbps ATM LAN can be carried over a 45 Mbps asynchronous DS3 line to a network in a different location. From there it can be switched into a 2.4 Gbps SONET (synchronous) transport system. A guaranteed amount of bandwidth can be allocated for fixed-bit-rate, delay-sensitive transmissions such as video and voice data. A variable amount of bandwidth can be allocated for the balance of network data that is less time-sensitive.

ATM Layers

The B-ISDN (Broadband Integrated Services Digital Network) model defines three ATM layers:

- The Physical Layer
- The ATM Layer
- The ATM Adaptation Layer (AAL)

In comparison with the OSI model, the three ATM layers are similar to the Physical Layer (Layer 1) and a portion of the Data Link Layer (Layer 2):

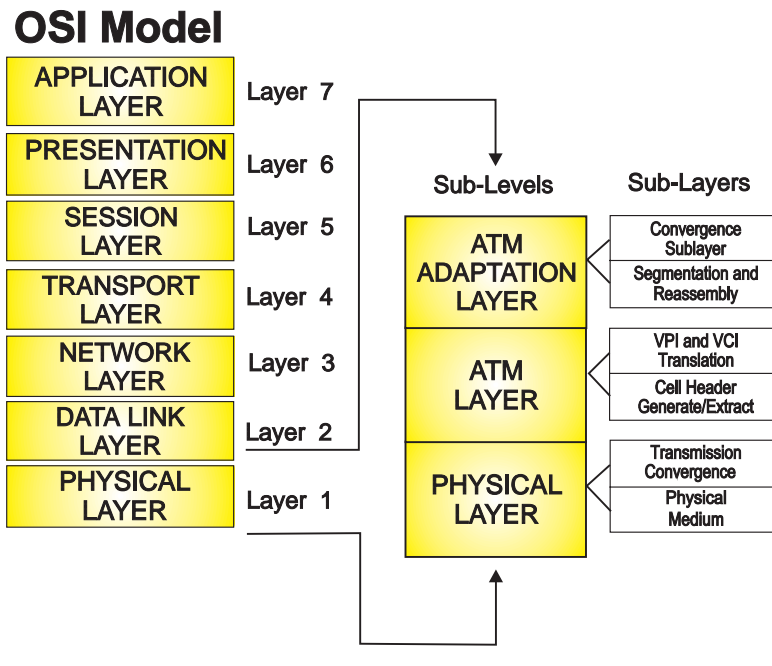

Figure C-4. ATM Compared to the OSI Model

Physical Layer

The ATM Physical layer defines the interface and framing protocol for the ATM network. The ATM Physical layer has two sublayers: Physical Medium Dependent (PMD) and Transmission Convergence (TC). The PMD sublayer provides bit transfer functions that are specific to the medium used in the network. The TC sublayer controls the transmission of frames over the physical medium.

ATM Layer

The ATM layer defines the cell structure and how cells move between connections in an ATM network. The ATM layer also creates the cells and controls the setup and teardown of virtual connections and virtual paths in the network.

ATM Adaptation Layer

The ATM Adaptation layer (AAL) enhances the services provided by the ATM layer to better serve the next higher layer's functions. It does this by providing timing and sequencing information that is tailored to the particular upper layer it is working with. It converts this information and the data itself to ATM cells according to its rules, and then converts the ATM cells back to data once they reach their destination. Currently there are four defined classifications of AAL service:

- **AAL1:** Supports the transfer of constant bit rate (CBR) data and provides mechanisms for maintaining timing and structure information for that data. Primarily intended for transporting small data samples, such as voice.
- **AAL2:** Definition currently under development by the ITU.
- **AAL3/4:** Supports the transfer of data that is sensitive to cell loss, but less sensitive to delay than AAL1-type data. AAL3/4 segments upper layer data into cells, each of which consists of a 2-octet header, a 2-octet trailer, and 44 octets of protocol data unit (PDU) payload. The header and trailer provide message- and cell-level sequencing, as well as per-cell CRC. This cell-level management comes at the cost of the additional overhead octets in each cell.

- **AAL5:** Like AAL3/4, AAL5 supports the transfer of data that is less sensitive to delay than AAL1-type data. AAL5 is a simpler and more space-efficient protocol that relies on higher-level services to handle cell loss and other errors. AAL5 encapsulates upper-layer SDUs into PDUs. Each PDU has a single trailer which contains the upper-layer SDU control information, SDU length, and a CRC to guarantee the integrity of the entire PDU. AAL5 then segments the PDU into cells, each of which uses the entire 48-octet cell payload to deliver user data.

The ATM Adaptation layer consists of two sublayers:

- **Segmentation and Reassembly (SAR) layer:** Converts data into cells, and cells back to data.
- **Convergence Sublayer (CS):** Meets the particular service requirements of the next higher layer.



Figure C-5. Protocol Model for AAL3/4 and AAL5

ATM Layers

In AAL3/4 and AAL5, the Convergence sublayer consists of two further sublayers:

- **Service Specific Convergence Sublayer (SSCS):**
Handles the details of the specific services of the higher layer.
- **Common Part Convergence Sublayer (CPCS):**
Converts upper-level SDUs to AAL PDUs.

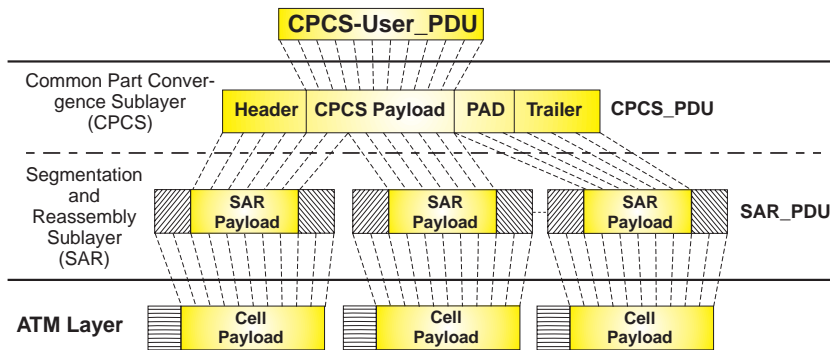

Figure C-6. AAL3/4 Sublayer

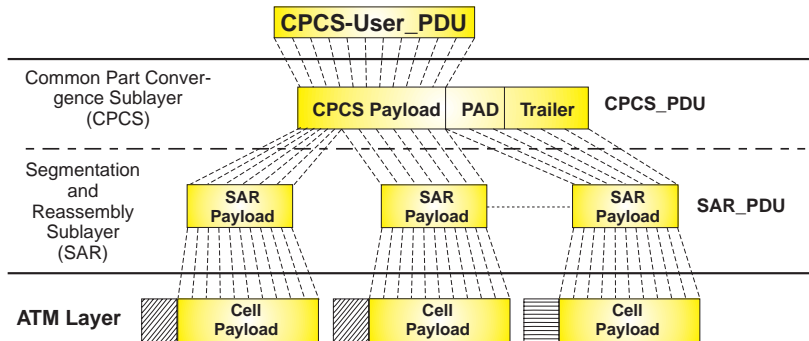

Figure C-7. AAL5 Sublayers

SONET/SDH

SONET (Synchronous Optical Network) is a North American multiplexing standard which defines a signal used in optical fiber networks. For ATM over fiber, OC-3c, with a base rate of 155.520 Mbps, is the most widely-used signal in the US.

SDH (Synchronous Digital Hierarchy) is the European equivalent of SONET. STM-1 (Synchronous Transport Mode, Level 1) is the European equivalent of OC-3c. STM-1 also has a base rate of 155 Mbps, but has slightly different framing information than the OC-3c signal.

Integrated Local Management Interface

Integrated Local Management Interface (ILMI) is the ATM Forum specification for incorporating network management into ATM networks. ILMI is based on the Simple Network Management Protocol (SNMP). It is used by the Interface Management Entity (IME) on the endstation and the switch to manage the physical link connecting them.

A subset of ILMI, known as *address registration*, is used when a station is connected to the ATM network. Address registration lets the endstation and the switch dynamically build a unique ATM Endstation Address (AESA). The ATM adapter's unique 6-byte identifier is used as the endstation identifier (ESI). The ATM switch determines a Network Prefix (link address), and the concatenation of the two define the endstation's unique ATM network address.

LAN Emulation

LAN Emulation (LANE) is designed to allow existing network applications and network protocols to run over ATM networks. It supports using ATM as a backbone for connecting *legacy* networks such as Ethernet, FDDI, and Token Ring. It is also designed to support efficient interaction for both directly attached ATM end systems (in their own subnet) and legacy end systems attached through Layer 2 bridging devices. Also, LAN Emulation allows multiple emulated LANs (ELANs) to exist on the same physically interconnected ATM network. Using an appropriate ATM network interface card, an ATM endstation can communicate with all of the following (as an example):

- An Ethernet segment on one ELAN
- A Token Ring segment on a second ELAN
- An FDDI segment on a third ELAN
- A fourth ELAN comprised of ATM nodes only (takes full advantage of high-speed ATM communications)

LAN Emulation supports a wide variety of protocols. This is achieved primarily by defining the functionality of the LANE interface at the MAC layer. This allows for protocol-independent data transfer between devices attached to the emulated LAN and to other legacy attached devices, as shown in Figure C-8. However, existing Ethernet/Token Ring/FDDI bridging problems are not solved by removing the old equipment and installing LAN Emulation based ATM equipment. Protocols or applications which are dependent upon the various MAC layer protocols such as SMT/Token Management and CSMA/CD are not supported. These MAC-dependent applications are designed to deal with specific media issues such as ring arbitration and collision detection. In addition, since each ATM link only carries traffic destined for

the one station attached to that ATM link, it is not possible for a given station to receive all of the emulated LAN's frames like it would on a shared media network.

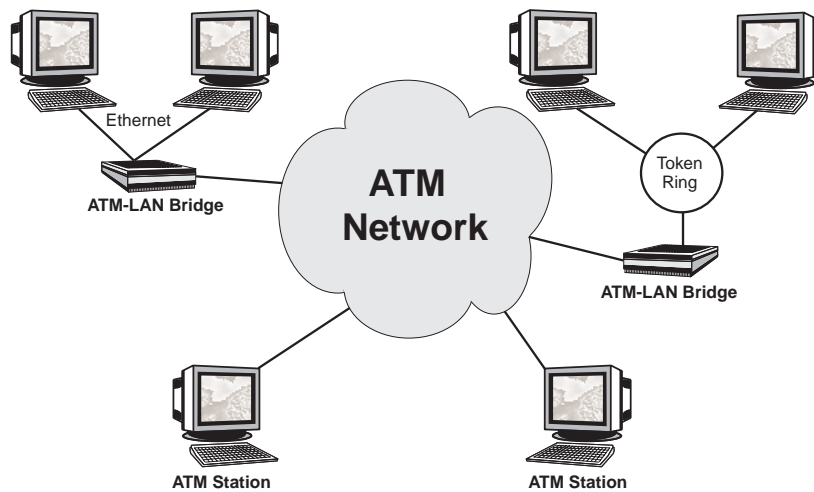

Figure C-8. ATM LAN Emulation

LAN Emulation provides a way for legacy LAN applications to operate over ATM while hiding the complexities of ATM point-to-point connections. The ATM stations are arranged into groups (through an ATM switch) that can implement and receive each other's broadcast/multicast requests. Support for Ethernet and Token Ring frame formats is provided so that legacy applications can run without modification over ATM networks. (FDDI uses Ethernet frames.) This is accomplished with true MAC level bridging as shown in Figure C-9. As a result, LAN Emulation supports multiple protocols, such as IP, IPX, and NetBIOS, across the ATM-LAN bridge.

LAN Emulation

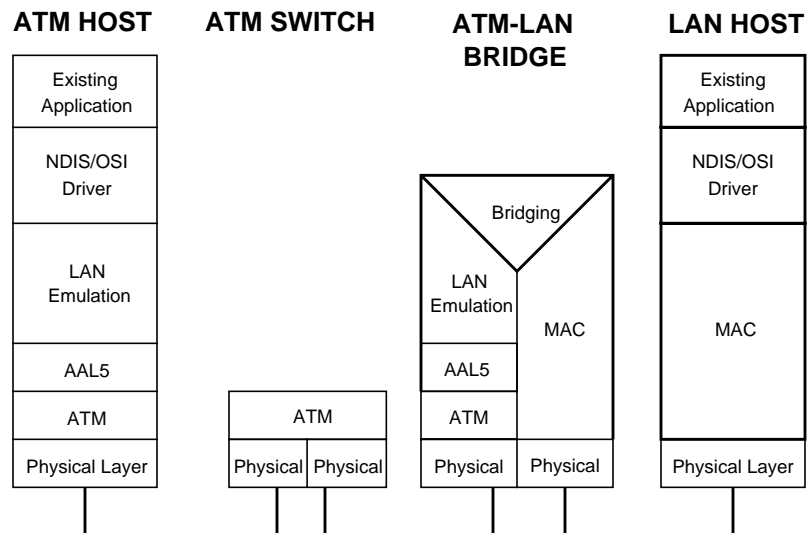

Figure C-9. LAN Emulation Protocol Stack

To illustrate how LAN Emulation works, Figure C-9 shows how an ATM host, an ATM-LAN bridge, and a legacy LAN host fit into the same network. The goal of LAN Emulation (on the ATM side of the bridge) is to convince the upper layer protocols that a MAC layer of a legacy LAN lies in the lower layers, when actually it does not. The only discernible difference is that ATM's emulated LAN interface operates at much higher transmission rates.

All LAN Emulation connections (as defined by the ATM Forum) utilize the AAL5 ATM Adaptation layer to reassemble and fragment the PDUs of legacy LANs into 53-byte ATM cells. The ATM-LAN bridge is responsible for implementing the MAC layer emulation to and from the legacy LAN. The LAN Host diagram in Figure C-9 emphasizes the fact that no

changes are required for existing software to run over ATM networks. The ATM switches merely transport the cells just as they would for any other connection.

LAN Emulation Services

The LAN Emulation Client (LEC) defines the interface between a MAC layer entity of an ATM node and the emulated LAN. The LAN Emulation Service defines how the protocol interoperates with multiple LECs. It provides functions for initialization, address registration and resolution, and data forwarding. The three components which implement these functions are the LAN Emulation Configuration Server (LECS), the LAN Emulation Server (LES), and the Broadcast and Unknown Server (BUS). Some vendors provide these services in one or more switches, while others provide them in endstation or edge devices.

LAN Emulation Configuration Server

The LECS provides a central point of contact for each LEC on the ATM network to acquire configuration information, including the address of the LES to use for a particular ELAN. LECS information is implemented and maintained by network personnel. Depending upon the vendor, the LECS implementation may provide numerous features including support for multiple ELANs, ELAN management based on MAC addresses, and other network management features. The key point is that the LECs can initially communicate with the LECS in order to locate the appropriate LES for their emulated LAN. The connection between the LEC and the LECS may be terminated when this transfer of information is complete.

LAN Emulation Server

The LES provides address resolution functions. This is a critical part of LAN Emulation due to the fact that MAC addresses are 6-byte entities and ATM addresses are 20-byte entities. Each LEC notifies the LES of its MAC-ATM address bindings. The LES stores the MAC-ATM relationship so it can resolve queries from other clients for these MAC addresses.

All LECs on an ELAN are connected to the same LES. All LECs on the same ELAN must use the same Maximum Transfer Unit (MTU) size and must log in with the LES before attempting to communicate with any other LEC in the group. An ELAN's MTU size depends on what type of legacy edge devices (if any) are being supported. If the network interface card at the ATM node supports multiple LECs, each client on the card may be configured to a different ELAN, and may have a different MTU size than the other clients. For example, a 1.5K MTU size is used to communicate with Ethernet subnets, 4.5K for Token Ring and FDDI, and 9K (or maximum rate) when all nodes on the ELAN are ATM nodes only. If more than one ELAN with the same MTU size is required, differentiating characteristics (for example, logical names) are configured in the LECS by network personnel.

The connection between the LES and each LEC is open as long as the client is up and running. The LES maintains information about all the clients currently connected to the server. When a client is disconnected or turned off, the LES removes all information about the client. Therefore, ATM networks using LAN Emulation support relocation of endstations with ease. Moving a station is a matter of physically moving the hardware to a new location, connecting it to the same or another ATM switch in the network, and turning on the power. At bootup, each client contacts the

LECS, the LECS supplies the ATM address for the appropriate LES, the client joins the LES, and can then start communicating with other clients on that ELAN.

Broadcast and Unknown Server

The BUS provides a simplified mechanism to support both broadcasting and bridged network functionality. In most protocols, the mechanism to translate network addresses to MAC addresses is implemented using the network topology's shared media broadcast capabilities. Since ATM is inherently non-shared, additional work must be done to enable every station on an ELAN to receive the broadcast and multicast frames. The BUS is a centralized server for the ELAN which accepts broadcast traffic from all clients in the group and then forwards that traffic to all the clients on a point-to-multipoint connection.

LAN Emulation Protocol

This section describes how the various phases of the protocol accomplish the goal of getting multiple stations to communicate in the ATM network environment.

1. Initialization

At power-up or a reset, the first action of an LEC is to establish a connection with an LECS. The protocol defines a multi-step procedure to ensure that the LECS can be reached in a variety of environments. The first mechanism involves getting the LESC address(es) via ILMI. If there are no addresses listed, or if none of the addresses work, the *well known* ATM address (defined by the ATM Forum) is used. An error occurs if this address does not work. Additionally an out-of-band mechanism for obtaining the required configuration

information may be implemented. This is done by allowing network personnel to enter the address of the appropriate LES directly to the LEC.

2. Configuration

Once a connection to the LECS is established, the LEC transmits a message to the LECS consisting of its own ATM address, MAC address, LAN type, and frame size (MTU)

5. Data Movement

Once the BUS connections are established, the LEC can begin forwarding frames. When a data frame needs to be transmitted, the LEC checks an internal table to see if a connection already exists for that MAC address. If so, it transmits the frame on that VCC. Otherwise, it queries the LES for the ATM address that corresponds with the MAC address. While waiting for a response, it forwards the frames destined for this MAC address to the BUS. For a device on the legacy side of a bridge, the bridge learns the device's MAC when the device starts transmitting, and future requests to resolve the address result in the bridge responding with its own ATM address.

Connections time out after periods of 20 minutes of inactivity in both directions. MAC entries received from the bridges are also timed out and reverified. This is done to support station movement on the legacy network where the edge devices do not have definitive knowledge of station movement activity.

LAN Applications

The advantage of LAN Emulation is that existing applications and protocols can be adapted to ATM merely by installing new ATM interfaces and drivers. The disadvantage is that these driver interfaces do not utilize any of the benefits of ATM, such as varying the quality of service, full ATM addressing, and other non-LAN protocol applications. For future software designs, the ATM Forum has developed a Native Service Interface which defines how new applications can be adapted to ATM networks, multiple vendors, and WinSock 2 support. This provides an evolutionary solution where existing applications can continue to work as before, while new applications are being developed to take full advantage of ATM capabilities. The two interfaces are able to coexist in the same end systems.

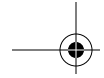

For More Information

For More Information

For more information about ATM networking, see

<http://www.atmforum.com>.

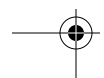

Glossary

The ATM Forum's glossary can be found on the Internet at <http://www.atmforum.com/atmforum/glossary/glosspage.html>

The following glossaries may also be helpful:

- Networking Glossary: <http://www.ctcnet.com/tips/glossary.htm>
- Computing Dictionary: <http://wfn-shop.Princeton.EDU/foldoc/>

802.2 IEEE ♦ Standards that govern the LLC within the Data Link layer of the OSI model. LLC frames carry user information between the nodes on a network and define the transmission of a frame between two stations. These standards are common across the various lower level standards within the Data Link and the Physical layers.

802.3 IEEE ♦ Standards that govern the use of the CSMA/CD (Carrier Sense Multiple Access/Collision Detection) network access method used by Ethernet networks.

802.5 IEEE ♦ Standards that govern the use of the token ring indicator and frame priority.

AAL (ATM Adaptation Layer) ♦ Converts packets of data to 53-byte cells for transmission on the network. Several AALs are defined to provide different types of service for ATM connections, and to provide a method of mapping data from a particular class of service into ATM cells in such a way that the data can be remapped into its original format at the other end of an ATM network.

ABR (Available Bit Rate) ♦ One of the two non-guaranteed service types (the other is UBR). With ABR, the network makes no absolute guarantee of cell delivery, but does guarantee a minimum bit rate for user transmission. ABR also makes an effort to keep cell loss as low as possible through a closed feedback loop conveying congestion information back to the source so the source can adjust its rates.

adapter ♦ A device, usually a user interface card, that physically connects an endstation to the network medium (for example, twisted pair, coaxial, fiber).

address registration ♦ A subset of ILMI which enables the switch and endstation to dynamically construct an endstation address.

Glossary

AESA (ATM Endstation Address) ♦ The 20-byte address defined by the ATM Forum for identifying endstations on a private ATM network.

ANSI (American National Standards Institute) ♦ An organization which coordinates, develops, and publishes standards used in the United States.

ARP (Address Resolution Protocol) ♦ The Internet protocol used to dynamically translate the Internet address of a network host to its LAN hardware address. This action is limited to LANs that support hardware broadcasts.

ASIC (Application Specific Integrated Chip)

Assert ♦ A signal is asserted by driving it to a logical true state. For positive-true signals this state is high logic voltage, and for negative-true signals this state is the low logic voltage.

ATM (Asynchronous Transfer Mode) ♦ A switched, connection-oriented technology for LANs and WANs. ATM accommodates a mix of data types, such as audio, video, and data, on a single network. The multiplexed information is organized into cells, and can be transported between network nodes at many different access and transmission speeds. Synonyms: asynchronous transmission, cell relay.

ATM Forum ♦ A communications industry organization made up of hundreds of vendors and users that defines ATM networking protocols.

ATM LAN ♦ Topology that consists of ATM switches and computer interfaces that provide high data rate connectivity for voice, video, and data (IP and multimedia). In addition, ATM interfaces are being integrated into existing LAN hubs and bridge/router platforms. Besides supporting high bandwidth, ATM LANs map to the WAN via central office ATM switches and services being deployed in the telecommunications world.

attenuation ♦ Signal power lost in a transmission medium as the signal travels from sender to receiver.

backbone ♦ A network configuration that connects LANs to form an integrated network.

bandwidth ♦ Capacity for transmitting data through a given circuit. Generally, the greater the bandwidth, the more information can be sent through a circuit during a given amount of time.

best effort ♦ A QoS class where no specific traffic parameters and no attempts are made to guarantee no cell loss or delay variation.

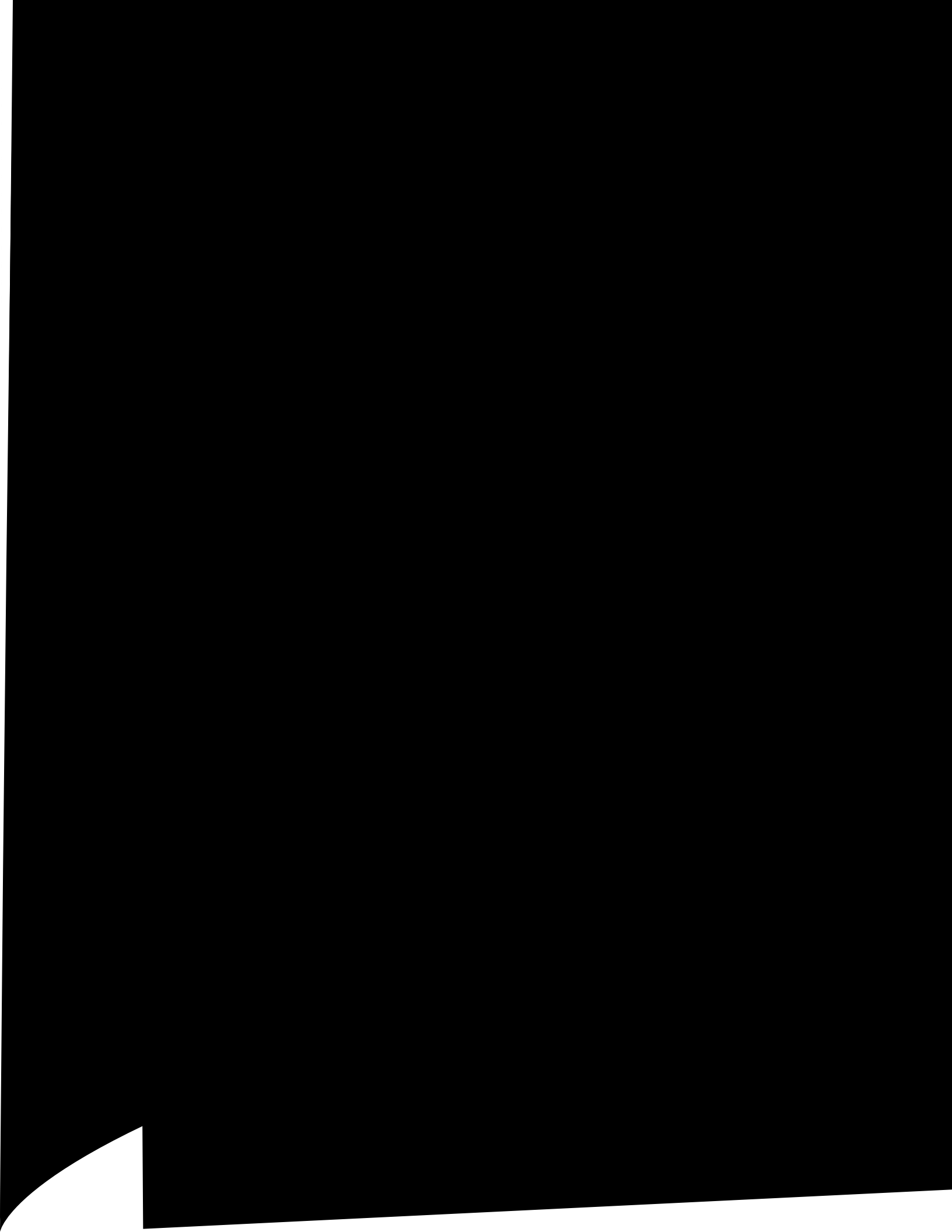

Glossary

cell FIFO ♦ Optimized DMA of ATM cells from reassembly engine to system memory requiring minimal CPU intervention.

cell switching ♦ ATM technology that combines the best features of circuit-and packet-switching technology and supports several classifications of AAL service (voice/video, packet/video, data).

circuit switching ♦ A connection-oriented service that uses switching techniques such as time division. It is an ideal mode for continuous, constant bandwidth applications, such as voice and video.

CLIP (Classical IP) ♦ A set of IETF-defined protocols for developing IP over ATM networks. The main issues in the transport of IP over ATM that CLIP resolves are packet encapsulation and address resolution.

CLP (Cell Loss Priority) ♦ A 1-bit field in the ATM cell header that corresponds to the loss priority of a cell. Lower-priority (CLP=1) cells can be discarded in congestion situations.

compression ♦ Method of reducing the quantity of data that must be transmitted across a network, primarily to enable the transmission of voice and video. The major compression standards are JPEG for still images, MPEG/MPEG-2 for full-screen motion images, and Px64 and H.261 for video conferencing.

CPC (Cell Personality Card)

CPCS (Common Part Convergence Sublayer) ♦ Part of the AAL convergence sublayer (CS), it must be present in the AAL implementation. Its task is to pass primitives to the other AAL sublayers (SAR, SSCS). It supports the functions of the standardized Common Part AALs: AAL1, AAL3/4, and AAL5.

CRC (Cyclic Redundancy Check) ♦ A bit errors detection technique that employs an algorithm to calculate a value for the information bits in a packet. The receiver, using the same algorithm, recalculates that value and compares it to the value received. If the two values do not agree, the transmitted packet is considered to be in error.

DLE (DMA/Descriptor List Element) ♦ The structure that describes to the PCI bus interface how to move data between the packet buffer and system memory.

DMA (Direct Memory Access) ♦ A fast method of moving data between two subsystems without processor intervention.

DMA Controller ♦ Provides control of the larger part of the system's DMA (Direct Memory Access) facility. The DMA controller responds to requests from the DMA device and provides address and control signals to the memory slaves and DMA device.

DMA Device ♦ The DMA device is typically located on a peripheral board on the EISA or ISA bus. The DMA device initiates DMA transfers, which are controlled by signals generated by the system DMA controller. The DMA device either presents or receives data during a DMA transfer and uses several signals to inform the DMA controller of the status of the transfer.

DS3 (Digital Standard 3) ♦ This ANSI standard defines the format of asynchronous data sent at the rate of 44.736 Mbps.

E.164 ♦ An ITU-defined 8-byte address format. In ATM it is typically used in public networks and is provided by the telecommunication carriers, while 20-byte NSAP-format addresses are used in private networks.

EFCI (Explicit Forward Congestion Indication) ♦ A 1-bit field in the cell header that contains information about whether congestion at an intermediate node has been experienced. The EFCI bit is set when, for example, a buffer threshold has been exceeded. When recognized by endstations, causes a reduction in the data rate.

EISA (Extended Industry Standard Architecture) ♦ A superset of the 8-bit/16-bit ISA bus architecture. By extending the capabilities of the ISA standard, EISA provides full compatibility with the ISA standard.

EISA Bus ♦ Includes all of the features and facilities provided by the industry standard architecture (ISA) bus plus an additional connector for new signals.

EISA Master ♦ Can request control of the bus, and assume complete control of all signals when it is granted the bus.

EISA Slave ♦ An EISA slave does not initiate bus cycles.

ELAN (Emulated LAN) ♦ See *LANE (LAN Emulation)* on page 169.

endstation ♦ A machine, intended for running user application programs, that is connected to a network. In an ATM network, the endstation is where an ATM connection is terminated or initiated.

fiber optic cable ♦ A transmission medium designed to transmit digital signals in the form of pulses of light.

FIFO (First In First Out) memory ♦ A type of dual-ported memory where the data is read out in the same order in which it was written in.

Float ♦ Signal is placed in the high impedance state.

fragmentation ♦ Data that has been broken up into smaller frames to meet requirements of the network to which they are being sent.

frame ♦ Data in a highly structured format for the purpose of transmission. *Frame, packet,* and *packet* are equivalent in most contexts.

FTP (File Transfer Protocol)

GFC (Generic Flow Control) ♦ A field in the ATM header that supports multiplexing functions. The GFC mechanism does not support simple flow control in ATM connections.

HDLC (High-level Data Link Control) ♦ A framing protocol defined by the ISO that can provide error-free Data Link layer services.

header ♦ Control information attached to the front of a frame or packet. In ATM cells, the header is the bits in a cell allocated for functions required to transfer the cell payload within the network.

HEC (Header Error Control) ♦ A cell header CRC field that guarantees the integrity of the cell header information.

host ♦ Generally, any computer on a network.

Host CPU ♦ The main system processor. The host CPU typically has its own local bus allowing the CPU to access cache or local memory without using the EISA bus. The host CPU accesses the EISA bus like any other bus master, with the exception of a few special features. The data size of the host CPU does not determine the EISA bus size; the CPU can have an 8-, 16-, or 32-bit data bus and still access the 16- or 32-bit EISA bus.

host name ♦ A unique name that identifies each host machine on a network.

ICMP (Internet Control Message Protocol) ♦ A Network layer Internet protocol which enables network IP packets to report errors and other relevant information for packet-processing purposes.

IEEE (Institute of Electrical and Electronic Engineers) ♦ An information exchange organization. Among other functions, it coordinates, develops, and publishes network standards for use in the United States, following ANSI rules.

IETF (Internet Engineering Task Force) ♦ Organization responsible for all Internet protocols (for example, IP, TCP, FTP).

ILMI (Integrated Local Management Interface) ♦ The ATM Forum standard, ILMI is used to manage the physical and logical interface between two ATM devices.

IME (Interface Management Entity) ♦ The logical management layer implementing ILMI.

IP (Internet Protocol) ♦ A networking protocol for providing a connectionless (datagram) service to the higher transport protocol. It is responsible for discovering and maintaining topology information and for routing packets across homogeneous or heterogeneous networks. Combined with TCP, it is commonly known as the TCP/IP platform.

IPX (Internetwork Packet Exchange Protocol) ♦ A connectionless Network layer protocol similar to IP.

ISA (Industry Standard Architecture) ♦ A well-known architecture for the buses in personal computers such as those used in IBM PCs and compatibles.

ISDN (Integrated Services Digital Network) ♦ An early, CCITT-adopted protocol reference model intended to provide a ubiquitous, end-to-end, interactive digital service for data, audio, and video. Synonym: narrowband ISDN.

ISO (International Standards Organization) ♦ An international body that creates networking standards, including the OSI model.

ITU (International Telecommunication Union) ♦ The international standards organization for telecommunications, previously known as the CCITT (International Telephone and Telegraph Consultative Committee). For more information, see <http://www.itu.ch>

isochronous ♦ A time-slot protocol that allows delivery of realtime data by dividing a time slot into equal-size mini slots allocated to different channels for synchronous transmission of information.

jitter ♦ See *CDV (Cell Delay Variation)* on page 165.

KB (Kilobytes) ♦ One kilobyte is equivalent to 1024 bytes when referring to memory size, and 1000 bytes when referring to speed.

Kbps (Kilobits per second)

KBps (Kilobytes per second)

LAN (Local Area Network) ♦ A data communications system designed to operate over a limited geographic distance, such as a single building.

LANE (LAN Emulation) ♦ An ATM Forum service specification that allows a connection-oriented ATM network to emulate legacy LAN (for example, Ethernet or Token Ring) services, such as broadcast.

LAP-D (Link Access Procedure-D) ♦ A Data Link layer procedure using D channel communications, typical of ISDN.

Glossary

LE-ARP (LAN Emulation ARP) ♦ The ARP used in LAN emulation for binding a requested ATM address to the MAC address.

LEC (LAN Emulation Client) ♦ Typically located in an ATM end system (for example, an ATM host), its task is to maintain address resolution tables and forward data traffic. It is uniquely associated with an ATM address.

LES (LAN Emulation Server) ♦ A server which provides support for the LAN emulation address resolution protocol (LE-ARP). The LECs register their own ATM and MAC addresses with the LES. An LES is uniquely identified by an ATM address.

LECS (LAN Emulation Configuration Server) ♦ A server whose main function is to provide configuration information to an LEC (such as the ELAN it belongs to or its LES).

LLC (Logical Link Control) ♦ The upper half of the Data Link layer in LANs. Performs error control, broadcasting, multiplexing, and flow control functions. See also *MAC (Medium Access Control)* on page 170.

LLC/SNAP (Logical Link Control/SubNetwork Attachment Point)

local ♦ Describes files and devices, such as disk drives, that are attached to, or on, your machine.

MAC (Medium Access Control) ♦ A set of protocols that are the lower part of the Data Link layer and comprise the basis of the IEEE LAN specifications. In general, MAC determines the way devices can transmit in a broadcast network. See also *LLC (Logical Link Control)* on page 170.

Master ♦ A device that uses EISA control signals to perform bus operations independent of the host CPU.

Mbps (Megabits per second) ♦ Transmission speed or rate of one million bits per second.

MBps (Megabytes per second) ♦ Transmission speed or rate of one million bytes per second or 8 Mbps.

MIB (Management Information Base) ♦ The specification that defines objects for referencing variables such as integers and strings. In general, it contains information about the network's management and performance (for example, traffic parameters). See also *ILMI (Integrated Local Management Interface)* on page 168.

MTU (Maximum Transmission Unit) ♦ The largest packet that can be sent over a given medium.

multicast ♦ A technique that allows copies of a single packet or cell to be passed to a set of destinations.

multimode fiber ♦ A large-core (62.5 micron) optical fiber through which multiple signals can propagate. Length constraint is 2 kilometers.

network ♦ An interconnection of multiple stations or systems that are able to send messages to and receive messages from one another.

NIC (Network Interface Card) ♦ A component that connects a station to a network (for example, a LAN). Synonym: adapter.

NMS (Network Management Station) ♦ The system responsible for managing a network or a portion of a network. The NMS communicates to network management agents (an agent resides in each managed node) using a network management protocol.

NNI (Network-to-Network Interface) ♦ The interface between two pieces of equipment on a public network.

node ♦ A device, such as a station or concentrator, connected to the network media, usually with an adapter.

NRZI (Non-Return to Zero Inverted) ♦ A data transmission technique where a polarity transition from low to high, or high to low, represents a logical 1. The absence of a polarity transition represents a 0.

NSAP (Network Services Access Point) ♦ In the OSI environment it is the SAP between the network and the transport layers. It identifies a Data Terminal Equipment by a unique address.

OAM (Operations and Maintenance) ♦ Set of administrative and supervisory actions regarding network performance monitoring, failure detection, and system protection.

OAM cell ♦ A cell that contains ATM layer management information. It does not form a part of the upper layer information transfer. Generated by hardware or network administrators. Cell header bits distinguish OAM cells from normal data cells.

OC-3c (Optical Carrier level 3, concatenated) ♦ An optical signal defined with a base rate of 155.52 Mbps. The concatenated signal is indivisible, that is, it cannot be multiplexed and demultiplexed.

OSI (Open Systems Interconnection) Model ♦ The 7-layer protocol model defined by the ISO for data communications.

packet ♦ Data in a highly-structured format for the purpose of transmission. *Frame*, *packet*, and *PDU* are equivalent in most contexts.

Glossary

packet buffer ♦ Memory used on the Interphase NIC to store data for fragmentation and reassembly. Synonym: Side RAM.

packet switching ♦ Statistical, connectionless switching based on information contained in variable-length packets.

payload ♦ Part of the ATM cell, it contains the actual information to be carried, and may also contain overhead. It occupies 48 bytes.

PDU (Protocol Data Unit) ♦ Data in a highly-structured format for the purpose of transmission. *Frame*, *packet*, and *PDU* are equivalent in most contexts.

PHY (Physical Layer) ♦ Layer 1 of the OSI model. Defines and handles the electrical and physical connections between systems. The Physical layer can also encode data in a form that is compatible with the medium (coaxial, twisted pair, fiber, and so on).

PING (Packet Internet Groper) ♦ An Internet protocol facility used to test the reachability of destinations by sending an ICMP echo request, and waiting for a reply.

PMD (PHY Medium Dependent) ♦ A standard that defines the medium and protocols to transfer symbols between PHYs.

point-to-multipoint connection ♦ A unidirectional, one-to-many VC that allows one station to simultaneously send data to the connected endstations.

point-to-point connection ♦ A bidirectional VC between two end points.

primitive ♦ Data and events passed between a layer service user and a layer service provider.

protocol ♦ A set of rules and conventions that govern the exchange of information between communicating parties.

PVC (Permanent/Provisioned Virtual Circuit) ♦ A VC provisioned for indefinite use in an ATM network, established by the network management system (NMS). See also *SVC (Switched Virtual Circuit)* on page 175.

Q.93B ♦ Early draft of the signalling specification now known as Q.2931, on which UNI 3.0 was based.

Q.2110 ♦ ITU Recommendation for specifying the UNI SSCOP.

Q.2931 ♦ ITU Recommendation derived from both Q.931 and Q.933 to provide SVC specifications and standards.

QoS (Quality of Service) ♦ The set of ATM performance parameters that characterize the traffic over a given VC.

QoS classes ♦ Five service classes defined by the ATM Forum in terms of the QoS parameters.

reassembly ♦ The portion of the ATM SAR that reassembles an incoming multiplexed stream of ATM cells into packets.

RFC (Request for Comment) ♦ IETF documents that contain proposed standards and specifications. RFCs can be either approved, or simply archived as historical recommendations.

RFC-1577 ♦ IETF standard for running Layer 3 IP traffic directly over ATM. See also *CLIP (Classical IP)* on page 166.

RJ-45 connector ♦ Standard 8-wire connector for IEEE 802.3 networks and some telephone applications.

SAAL (Signalling AAL) ♦ Service-specific parts of the AAL protocol responsible for signalling. Its specifications, being developed by the ITU, were adopted from N-ISDN.

SAP (Service Access Point) ♦ Functional interface between the layers in the OSI model through which lower layers provide services to the higher layers along with PDUs.

SAR (Segmentation and Reassembly) ♦ The lower half of the AAL. The segmentation portion inserts data from packets into cells, adds any necessary header or trailer bits to the data, and passes the 48-octet payload to the ATM layer. Each AAL type has its own SAR format. At the destination, the reassembly portion extracts the cell payload and rebuilds the packet.

SAR-PDU ♦ The 48-octet PDU that the SAR sublayer exchanges with the ATM layer. It is comprised of the SAR-PDU payload and any control information that the SAR sublayer adds.

SC (Subscriber Connector) ♦ A connector where the transmit and receive fibers are one keyed module plug that latches.

SDH (Synchronous Digital Hierarchy) ♦ A hierarchy that designates signal interfaces for very high-speed digital transmission over optical fiber links. See also *SONET (Synchronous Optical Network)* on page 174.

SDU (Service Data Unit) ♦ User data passed through a SAP between the layers of the OSI or a similar model.

signalling ♦ An ATM connection procedure that dynamically implements explicit routes through switches to establish a communication link with another station on the network.

Glossary

single-mode fiber ♦ A small-core (9 micron) optical fiber through which only one signal can propagate. Length constraint for the device used in Interphase products is 20 kilometers.

Slave ♦ A memory or I/O device that uses EISA control signals to interface to the bus.

SLIP (Serial Line Internet Protocol) ♦ A protocol for transmitting and receiving IP datagrams via a serial interface.

Slot Specific Signal ♦ Each connector has a unique variant of the signal (instead of a single signal that is bused to all connectors).

SNMP (Simple Network Management Protocol) ♦ A high-level, standards-based protocol for network management, usually used in TCP/IP networks. An SNMP manager controls and measures the activities of SNMP agents that are embedded in nodes and network devices on the network. SNMP relies on MIBs embedded in the network resources to monitor and control the network.

SONET (Synchronous Optical Network) ♦ An ANSI-defined standard for high-speed and high-quality digital optical transmission. It has been recognized as the North American standard for SDH.

SSCF (Service Specific Coordination Function) ♦ Part of the SSCS portion of the SAAL. Among other functions, it provides a clear interface for relaying user data and providing independence from the underlying sublayers. See also *SSCOP (Service Specific Connection-Oriented Protocol)* on page 174.

SSCOP (Service Specific Connection-Oriented Protocol) ♦ Part of the SSCS portion of the SAAL. SSCOP is an end-to-end protocol that provides error detection and correction by retransmission and status reporting between the sender and the receiver. It also guarantees delivery integrity. See also *SSCF (Service Specific Coordination Function)* on page 174.

SSCS (Service Specific Convergence Sublayer) ♦ One of the two components of the Convergence Sublayer (CS) of the AAL. It supports the specific requirements of upper-layer protocols.

ST (Straight Through) connector ♦ A connector where the transmit and receive fibers have separate twist-on connections.

station ♦ An addressable node on the network capable of transmitting and receiving data.

STM (Synchronous Transfer Mode) ♦ A packet-switching approach where time is divided into time slots assigned to single channels during which users can transmit periodically. Basically, time slots denote allocated (fixed) parts of the total available bandwidth.

STM-1 (Synchronous Transport Module-1) ♦ An ITU-defined SDH physical interface for ATM digital transmission at the rate of 155.52 Mbps.

STM-n (Synchronous Transport Module-n) ♦ An ITU-defined SDH physical interface for ATM digital transmission at n times the basic STM-1 rate. STM-n and SONET STS-3n transmission rates are equivalent.

STS (Synchronous Transport Signal)

subnet address ♦ An extension of the Internet addressing scheme. Using this method, a site can use a single Internet address for multiple physical networks.

SVC (Switched Virtual Circuit) ♦ A software-created dynamic connection between two network nodes. SVCs are created “on demand” and torn down upon completion of the data transfer.

symbol ♦ The smallest signaling element used by the MAC sublayer. The symbol set consists of sixteen data symbols and sixteen nondata symbols. Each symbol corresponds to a specific sequence of code bits (code group) to be transmitted by the PHY.

synchronous transmission ♦ A data transmission scheme where the interval between transmitted characters is fixed so that start and stop bits are not required. As opposed to asynchronous transmissions, synchronous transmissions are guaranteed a specific percentage of bandwidth on the network medium.

TCP/IP (Transmission Control Protocol/Internet Protocol) ♦ A set of communications protocols that define how different types of computers talk to each other. It is the standard architecture for internetworking multiple organizations, and the common link that ties the huge Internet together.

TELNET ♦ A TCP/IP protocol that supports remote terminal operations via a network.

Token Ring ♦ A 4 Mbps or 16 Mbps network that uses a ring topology and a token-passing access method.

UBR (Unspecified Bit Rate) ♦ With UBR, the source specifies no traffic parameters, and therefore the network does not guarantee transmission quality.

Glossary

UNI (User-Network Interface) ♦ Definition of the interface between an end system and an ATM switch. Defines a set of specifications for signaling. Produced by the ATM Forum.

UNI 3.0 ♦ ATM Forum UNI specification for the physical (PHY) and ATM layers, the ILMI, OAM (traffic control), and PVC support.

UNI 3.1 ♦ A corrected version of UNI 3.0, this specification also includes SSCOP standards.

UNI 4.0 ♦ This UNI specification covers signalling issues in ABR and VP, as well as QoS negotiation.

UTP (Unshielded Twisted Pair) ♦ Type 3 cable with one or more twisted pairs where the wiring is not protected from electromagnetic and radio frequency interferences. There are two main categories of UTP used in ATM: category 3 for 25 Mbps, and category 5 for 155 Mbps. See also *CAT-3 (Category 3 UTP)* on page 165 and *CAT-5 (Category 5 UTP)* on page 165.

VBR (Variable Bit Rate) ♦ The bit rate available to a user for the transfer of user information that requires a guaranteed service for a bounded variable transmission rate.

VBR-RT (Variable Bit Rate—Real Time) ♦ One of the service types for transmitting traffic which is timing- and control-dependent and is characterized by having both average and peak cell rates. VBR-RT is suitable for carrying traffic such as packetized (compressed) video and audio.

VBR-NRT (Variable Bit Rate—Non-Real Time) ♦ One of the service types for transmitting traffic which is not timing-critical and is characterized by having both average and peak cell rates. VBR-NRT is well-suited to long data packet transfers.

VC (Virtual Channel/Connection/Circuit) ♦ A logical transmission path or connection between two network endpoints.

VCI (VC Identifier) ♦ A 16-bit identifier in an ATM cell header which, when combined with the VPI, identifies the VC to the next ATM device.

VLAN (Virtual LAN) ♦ A networking environment where users on physically independent LANs are interconnected in such a way that it appears they are in the same LAN workgroup.

VP (Virtual Path) ♦ A logical pipe which can contain a group of VCs that connect network devices.

VPI (VP Identifier) ♦ A field in an ATM cell header which, when combined with the VCI, identifies the VC to the next ATM device.

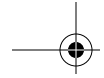

WAN (Wide Area Network) ♦ A network spanning a large geographical area that provides communications among devices on a regional, national, or international basis.

workstation ♦ A networked computer typically reserved for end-user applications.

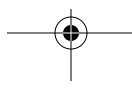

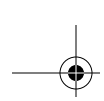

Glossary

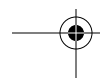
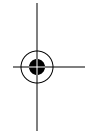

Index

When using this index, keep in mind that a page number indicates only where referenced material begins. It may extend to the page or pages following the page referenced.

A

AAL5 statistics 128
 adapter
 installation to motherboard 8
 LED state and function 129
 multiple boards
 NetWare Server 97
 Windows NT 25
 network connections 11
 adapter installation 41
 address registration 64
 advanced settings, CellView 82
 ARP protocol, NetWare 99
 ARP server setup, IP over ATM .. 72, 117
 ASIG command, NetWare 95
 ATM
 standards compliance 137
 Switch 145, 146
 switch configuration 58
 switch requirements 4
 autoexec.ncf file
 adding driver commands 95
 configuring multiple adapters 100

B

BIND IP command, NetWare 99
 BIND IPX command, NetWare 99
 bootup problems 131
 broadcast address 41
 broadcast setting, PVC 70
 BUS 39

C

caution
 ATM switch requirements 19, 39

cvconf file 35, 46, 53
 mixing frame types, NetWare 90
 remove existing driver
 NetWare Server 88
 Windows NT 21
 wiring connectors 142
 CellView
 address registration 64
 advanced settings 82
 connections display 83
 debugging options 84, 133
 ELAN services 73
 global settings 82
 ILMI port detection 64
 IP over ATM
 ARP server 72, 117
 enable 70, 116
 IP address 71, 117
 PVC only 71
 PVC table 72
 IP over ATM clients
 PVC only 116
 LEC
 ELAN name 67, 110
 ELAN type 67, 110
 enable 65, 109
 L3MTU size 68
 LES/LECS address 68
 MAC address 66, 110
 MTU size 67, 110
 PVC only 65, 109
 PVC table 68
 LECS
 default ELAN type 75

default MTU size	74
enable	74
well known address	74
LES	
client mappings	78
ELAN name	77
ELAN type	78
enable	76
MTU size	77
strict setting	78
main dialog	59
nonstandard prefixes	65
prerequisites	59
setup routines	62
signalling	
UNI setup	64
VCI display	64
VPI display	64
start-up	
NetWare Server	104
start-up/sequence commands	

grounding strap.....	6	PVC table.....	72
H		IP over ATM client	
hardware		setup	
adapter installation	6	CellView for NetWare.....	115
ATM switch requirements	4	IP over ATM clients.....	39
driver requirements		enable.....	101
NetWare Server	88	verify.....	128
Windows NT.....	20	IP over ATM server	39
electrical warning	7	L	
inserting adapter in motherboard.....	8	L3MTU size, LEC.....	68
network connections	11	LAN Emulation	
Header, cell	144	compliance.....	137
Host		LAN Emulation Client (LEC)	
EISA utility.....	9	initialize	
I		Windows NT.....	22
IEEE compliance	137	setup	
ifconfig options	41	CellView for NetWare.....	108
ILMI port detection	64	LAN Emulation Configuration Server	
INSTALL utility, NetWare.....	89, 102	setup	
installation	41, 48	CellView for NetWare.....	121
adapter hardware	6	LAN Emulation Server (LES)	
driver for NetWare Server	87	setup	
driver for Windows NT.....	19	CellView for NetWare.....	123
driver quick install		LANE clients (LECs)	
Windows NT.....	14, 18	enable.....	101
electrical warning	7	verify.....	128
grounding strap	6	LANE services	39
inserting adapter in motherboard.....	8	LEC	
network connections	11	ELAN name	67, 110
Installing hardware		ELAN type	67, 110
EISA configuration utility	9	enable.....	65, 109
IP address	41	L3MTU size	68
NetWare Server	92, 99	LES/LECS address	68
Windows NT	23	MAC address	66, 110
IP mask, NetWare driver	92, 99	MTU size	67, 110
IP over ATM		PVC encapsulation.....	70
ARP server.....	72, 117	PVC only	65, 109
enable.....	70, 116	PVC table.....	68
IP address.....	71, 117	LECS	
PVC encapsulation.....	73	default ELAN type.....	75
PVC only.....	71, 116	default MTU size.....	74
		enable.....	74

- well known address 74
- LED**
- diagnostics 130
 - state and function 129
 - troubleshooting 130
- LES**
- client mappings 78
 - ELAN name 77
 - ELAN type 78
 - enable 76
 - MTU size 77
 - strict setting 78
- LES/LECS address for LEC 68
- link LED 130
- LOAD command, NetWare 97
- LOAD TCPIP command, NetWare ... 100
- M**
- MAC address, LEC 66, 110
 - motherboard expansion slots 8
 - mount command 16, 17, 42, 49
 - MTU size
 - LEC 67, 110
 - LECS 74
 - LES 77
 - multiple adapters
 - NetWare Server 100
 - Windows NT 25
- N**
- net mask 41
 - NetWare Server
 - commands
 - BIND IP 99
 - BIND IPX 99
 - LOAD (format) 97
 - LOAD ASIG 95
 - LOAD CVCONF 95
 - LOAD TCPIP 100
 - driver installation 89
 - driver overview 87
 - driver removal 102
 - endstation requirements 88
 - initializing clients 94
 - INSTALL utility 89
 - network number 93
 - parameter configuration 92
 - protocol configuration 92
 - quick installation guide 18
 - selecting a driver 90, 94
 - network connections
 - adapter 11
 - specifications 139
 - network interface 41, 137
 - network number, NetWare 93
 - network problems 133
 - nonstandard prefixes, ATM switch 65
- O**
- Output Link (VPI/VCI) 146
 - overview 39
- P**
- parameter configuration, NetWare 92
- PCI**
- adapter installation 7
 - expansion slot 8
 - pin assignments 141
 - pin assignments for RJ-45 connector 142
 - pkginfo command 41, 49
 - prefixes, nonstandard network 65
 - primary WINS server 23
 - protocol configuration, NetWare 92
- PVC**
- broadcast setting, LEC 70
 - encapsulation 70, 73
 - table 68, 72
- PVC (Permanent Virtual Circuit)**
- setup
 - CellView utility 111, 117
- PVC (RFC-1483)** 39
- PVC only**
- IP over ATM 71, 116
 - LEC 65, 109
- Q**
- quick installation guide

NetWare Server	18	requirements	
Windows NT	14	NetWare Server.....	88
R		Windows NT.....	20
reboot command.....	34, 47, 54	selecting a driver	
removing drivers		NetWare Server.....	90, 94
NetWare Server	102	Windows NT.....	21
Windows NT	25	Solaris	
RFC-1483 PVC	39	driver availability	2
RJ-45 connections		Solaris version required.....	40
pin assignments.....	142	SONET/SDH compliance	137
specifications.....	139	specifications	
running CellView		cables and connectors.....	139
NetWare Server	104	starting CellView	
RX/TX, RJ-45 pin assignments	142	NetWare Server	104
S		stat refresh rate, CellView.....	82
SC Duplex connections		statistics, CellView.....	81, 126
specifications.....	139	status LED.....	130
secondary WINS server	23	strict setting, LES	78
selecting a driver		subnet mask	
NetWare Server	90, 94	NetWare Server (IP mask)	92, 99
Windows NT	21	Windows NT	23
shutdown command.....	34, 47, 54	SVCs	39
signalling		switch configuration.....	58
ATM switch requirements	4	switch requirements	39
compliance.....	137	Switch, ATM.....	145, 146
start commands	62	switch, signalling requirements	4
UNI setup.....	64	system memory	40
VCI display.....	64	system memory required	20, 88
VPI display	64	T	
signalling statistics.....	128	TCP/IP	
software drivers		NetWare Server	92, 99
installation		Windows NT	23
NetWare Server	89	tools required	
NetWare overview	87	list.....	6
overview.....	3	usage	7
quick installation guide		warning.....	7
NetWare Server	18	Troubleshooting	127
Windows NT.....	14	troubleshooting	
removal		bootup problems	131
NetWare Server	102	LEDs.....	130
Windows NT	25	network problems.....	133
		TX/RX	

UTP connectors 141
TX/RX, RJ-45 pin assignments 142

U

UNI 3.0/3.1 39
UNI setup 64
UNI signalling requirements 4
UnixWare
 driver availability 2
UTP connections
 data rates 137
 specifications 139
 wiring diagrams 141

V

VCI display 64
Virtual Circuit Connection 144
Virtual Path 145
VPI display 64

W

warning
 electrical shock 7
well known address, LECS 74
Windows NT
 driver overview 19
 driver removal 25
 endstation requirements 20
 Network Settings dialog 22
 quick installation guide 14
 selecting a driver 21
WINS server configuration 23

Product Registration Card

Please take a minute to register your Interphase product. This will enable us to notify you about software updates and product enhancements.

Name _____
Title _____
Company Name _____
Company Address _____
City _____
State _____ Zip _____ Country _____
Province _____
Telephone () _____
Fax () _____
E-mail Address _____

Which product did you purchase? _____
Serial Number _____
Where did you purchase this product (company name)? _____
Date Purchased _____

Number of client nodes at this site: _____

Operating System(s) being used with this product:

- | | | | |
|----------------------------------|-------------------------------------|--------------------------------------|-------------------------------------|
| <input type="checkbox"/> Solaris | <input type="checkbox"/> SunOS | <input type="checkbox"/> AIX | <input type="checkbox"/> NetWare |
| <input type="checkbox"/> HP-UX | <input type="checkbox"/> IRIX | <input type="checkbox"/> Mac OS | <input type="checkbox"/> Windows NT |
| <input type="checkbox"/> PC NFS | <input type="checkbox"/> DEC Ultrix | <input type="checkbox"/> Other _____ | |

Operating System Version: _____

Network Protocol(s) in use:

- | | | | |
|---------------------------------|------------------------------|------------------------------------|--------------------------------------|
| <input type="checkbox"/> TCP/IP | <input type="checkbox"/> IPX | <input type="checkbox"/> AppleTalk | <input type="checkbox"/> Other _____ |
|---------------------------------|------------------------------|------------------------------------|--------------------------------------|

We welcome your comments, ideas, and suggestions. You can fax additional comments to 214/654-5500, or send them to intouch@iphase.com

If you are interested in receiving information on other products from Interphase, please check the appropriate boxes:

- | | | | | |
|------------------------------|-------------------------------|-------------------------------|--|------------------------------------|
| <input type="checkbox"/> ATM | <input type="checkbox"/> FDDI | <input type="checkbox"/> SCSI | <input type="checkbox"/> Fibre Channel | <input type="checkbox"/> 100 BaseT |
|------------------------------|-------------------------------|-------------------------------|--|------------------------------------|

If you are mailing this card from outside the United States, please add postage.

11/96

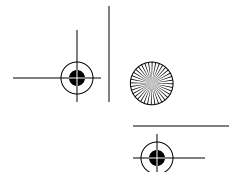
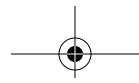
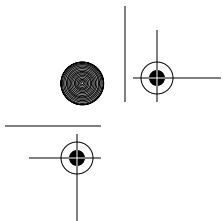

NO POSTAGE
NECESSARY
IF MAILED
IN THE
UNITED STATES

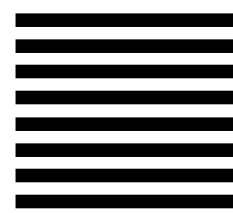

4875.hk Page 186 Wednesday, October 15, 1997 2:27 PM

BUSINESS REPLY MAIL
FIRST-CLASS MAIL PERMIT NO. 5784 DALLAS TEXAS

POSTAGE WILL BE PAID BY ADDRESSEE

ATTN: WARRANTY DEPARTMENT
INTERPHASE CORPORATION
13800 SENLAC DR
DALLAS TX 75234-9600

